

# DETAILING OF CONCRETE MASONRY

Volume 2 – Hollow Units 140/190



**Concrete masonry:  
Strong, durable and attractive**



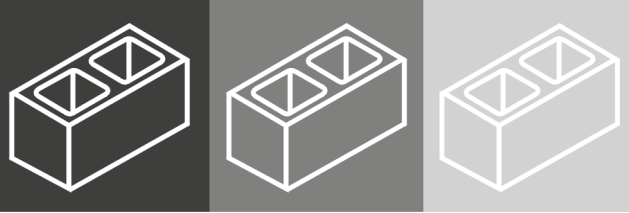

Published by  
Concrete Manufacturers Association  
Block D, Lone Creek, Waterfall Office Park,  
Bekker Road, Midrand  
Telephone: +27 11 805 6742  
Fax: +27 86 524 9216  
Email: [main.cma@gmail.com](mailto:main.cma@gmail.com)  
Website: [www.cma.org.za](http://www.cma.org.za)  
Fifth Edition – revised 2011

# **Guidelines on the DETAILING OF CONCRETE MASONRY**

**VOLUME 2 HOLLOW UNITS – 140mm and 190mm**

**Editors: J W Lane J E Cairns JH Catsavis**

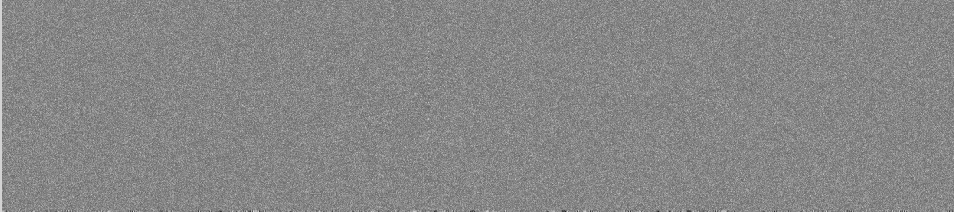
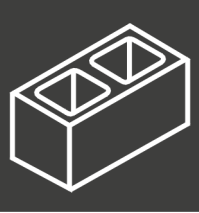

## **PREFACE**

Successful masonry depends on adequate design and specification of materials, sound construction practice and an acceptable quality of workmanship. Good workmanship is in turn dependent on access to accepted norms of local detailing practice and materials.

The purpose of this booklet is to provide guidelines for the detailing of concrete masonry structures. It should be read in conjunction with the Concrete Manufacturers Association's Masonry Manual, the National Building Regulations, and National Home Builders Registration Council Home Building Manual the relevant South African Bureau of Standards specifications and codes of practice.

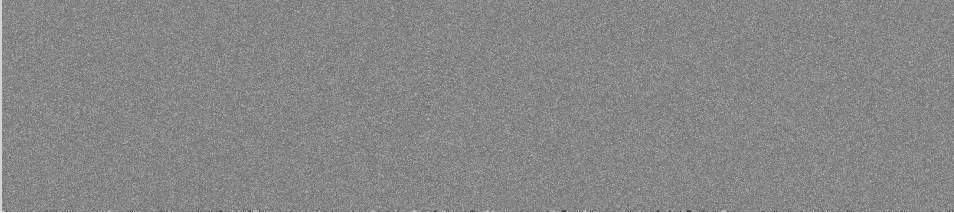
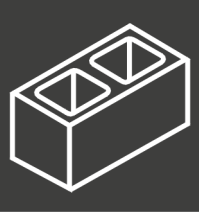

# CONTENTS

<b>Preface</b>	<b>3</b>
<b>Reference coding system</b>	<b>6</b>
<b>General notes</b>	<b>7</b>
<b>DETAILS OF CONCRETE MASONRY</b>	<b>9</b>
<b>140 mm and 190 mm HOLLOW UNITS</b>	
<b>SINGLE LEAF WALLS (REFERENCE H-**-*)</b>	

	<b>COMPUTER</b>	
	<b>REFERENCE NUMBER</b>	
Foundation walls	– external walls	H-FG-01/04 9–10
	– internal walls	H-FG-05/07 11
Sills		H-SI-01/05 12
Lintels		H-LI-01/04 12
Window frames		H-WF-01/02 13–14
Door frames		H-DF-01/03 15–17
Suspended floors	– index	– 18
	– external walls	H-SF-01/10 19–23
	– internal walls	H-SF-11/17 24–25
Parapet walls		H-PW-01/05 26
Roof screed		H-RS-01 26
Roof trusses		H-RT-01/07 27–28
Masonry bond patterns		H-BP-01/08 29
Joint profiles		H-JP-01/02 30
Column/Wall intersections	– wall to wall	H-WW-01/09 31–33
	– wall to column-masonry	H-CM-01/06 34–36
	– wall to column-pilasters	H-CP-01/03 37
	– wall to column – concrete	H-CC-01/13 38–42
	– wall to column – steel	H-CS-01/12 43–47
Beam to Wall		H-BW-01/02 48
Control joints		H-CJ-01/05 49–52
Reinforcing		H-RE-01/13 53–58
Air-Conditioning unit		H-AC-01 59
Services		H-SV-01/06 60–62
<b>Appendices</b>		<b>63</b>
Appendix A:	Definitions	65
Appendix B:	References	66
Appendix C:	Anchors-Walls	68
Appendix D:	Roof Fixing	69
Appendix E:	Ties, Straps and Bedding Reinforcement	70
Appendix F:	Detailing practice for reinforced masonry	71
Appendix G:	V-Joints in plaster and mortars	83

Reference:

Refer to: Volume 1 for details of 140 mm solid unit walls  
Volume 3 for details of cavity walls



## GUIDELINES ON THE DETAILING OF MASONRY STRUCTURES REFERENCE CODING SYSTEM

### DESCRIPTION OF WALL

**SOLID UNIT SINGLE LEAF WALLS** 140mm

**HOLLOW UNIT SINGLE LEAF WALLS** 140 AND 190 mm

**CAVITY WALLS** 240 TO 290 mm

### Computer Reference Number

S\_\*\*\_\*\*

H-\*\*-\*\*

C-\*\*-\*\*

### POSITION IN WALLS

**AIR**CONDITIONING UNITS

H-AC-\*\*

**BEAM TO WALL**

H-BW-\*\*

**BONDING PATTERNS**

H-BP-\*\*

**CONTROL JOINTS**

H-CJ-\*\*

**DOOR FRAMES**

H-DF-\*\*

**FOUNDATIONS AND GROUND FLOOR SLAB**

H-FG-\*\*

**INTERSECTION**

WALL TO **W**ALL

H-WW-\*\*

WALL TO **C**OLUMN (**C**ONCRETE)

H-CC-\*\*

WALL TO **C**OLUMN (**S**TEEL)

H-CS-\*\*

WALL TO **C**OLUMN (**M**ASONRY)

H-CM-\*\*

WALL TO **C**OLUMN (**P**ILASTERS)

H-CP-\*\*

**JOINT PROFILES**

H-JP\*\*

**LINTELS**

H-LI-\*\*

**PARAPET WALLS INCLUDING COPING**

H-PW-\*\*

**REINFORCING**

H-RE-\*\*

**ROOF SLABS**

H-RS-\*\*

**ROOF TRUSSES**

H-RT-\*\*

**SERVICES**

H-SV-\*\*

**SILLS**

H-SI-\*\*

**SUSPENDED FLOOR**

H-SF-\*\*

**WINDOW FRAMES**

H-WF-\*\*

**NOTES**

H-\*\*-NB

### Notes:

The computer reference number is the file name under which the individual drawings are stored. The last two digits (indicated with an asterix above) represent the numbering of drawing in that particular category. Where the last two digits are replaced with the letter "NB", this file contains notes which are pertinent to the drawings in the particular category.

## GENERAL NOTES

Concrete masonry has wide applications in modern industrial, commercial, educational and residential buildings.

The main types of masonry walls dealt with in these guidelines are: single leaf walls using solid units (Part 1), single leaf walls using hollow units (Part 2) and cavity walls (Part 3).

The details shown in this publication are intended merely as a guide. Each construction situation is unique and there are many factors to be considered before a detail is finalised – far too many for inclusion here.

The purpose of good detailing is to assist in achieving sound construction and a buildable structure that will perform well in service.

The following factors must be taken into account when detailing for concrete masonry structures:

### Materials:

- Concrete masonry units:
  - solid/hollow – dimensions
  - non-face/face – texture, colour and profile properties and availability.
- Mortar:
  - Class to be used plus materials. (Will mortar sand result in high shrinkage of mortar and wall?)

### Environmental conditions:

- Environment:
  - Orientation
  - Likelihood of significant movement due to temperature and moisture variations
- Earth/Seismic movement

### Service conditions:

- Loading:
  - dead, imposed, wind, unexpected
- Aggressive conditions:
  - corrosion

### Type of structure

- Unreinforced/reinforced/prestressed
- Composite structure:
  - masonry/reinforced concrete
  - masonry/prestressed concrete
  - masonry/structural steel
  - masonry/timber and their interaction

- Degree of fixity between elements and likely movement.
- Special finishes and specification requirements.
- Workmanship quality

### Design

- Modular co-ordination of building elements-work to 200mm module horizontally and 100mm (and 200mm when using facings) vertically.

Details in these guidelines do not necessarily apply to masonry structures over four storeys in height.

Unless otherwise stated, the details shown are based on the "deemed to satisfy" clauses of SANS 10400 and the NHBRC Home Building Manual (HBM).

In this code of practice, only strip foundations are covered, but there may be a need for special foundations in particular cases. Authoritative advice should be obtained in this regard.

The information contained in this publication is intended as a guide only. The Concrete Manufacturers Association cannot be held responsible for its interpretation and use.

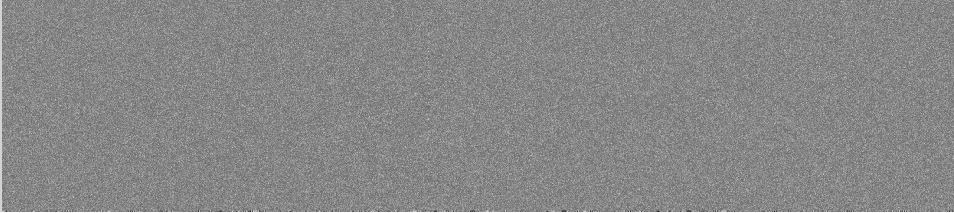

# FOUNDATION AND WALL DETAILS – EXTERNAL WALLS

**H-FG-01**  
See H-FG-NB

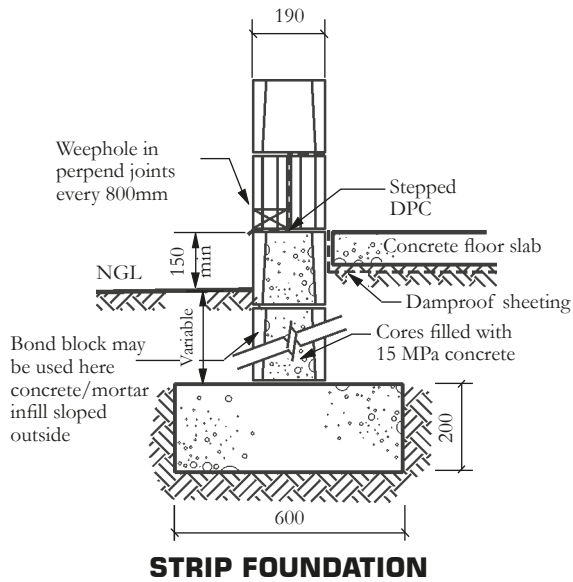

**H-FG-02**  
See H-FG-NB

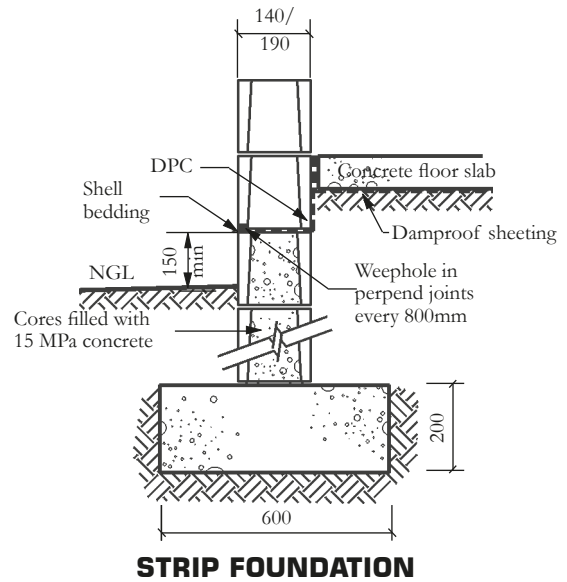

**H-FG-03**  
See H-FG-NB

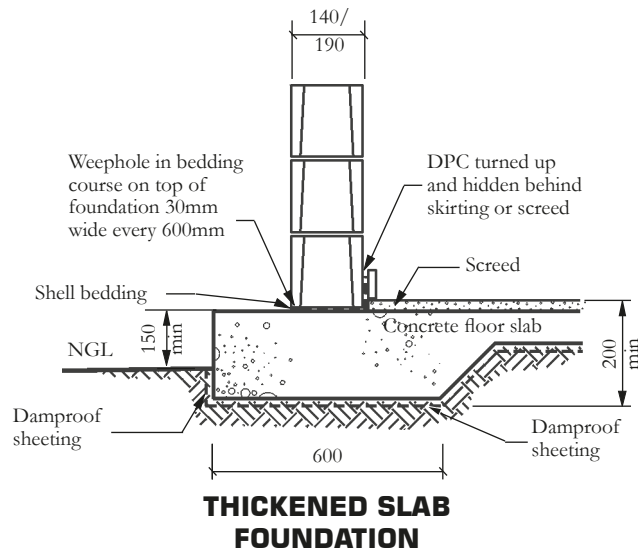

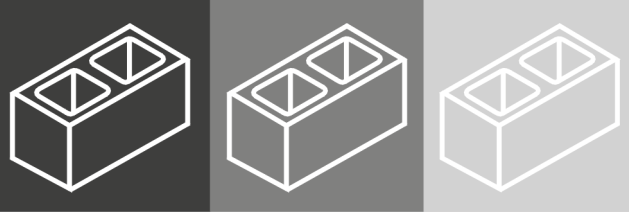

## FOUNDATION AND WALL DETAILS – EXTERNAL WALLS

### H-FG-03

See H-FG-NB

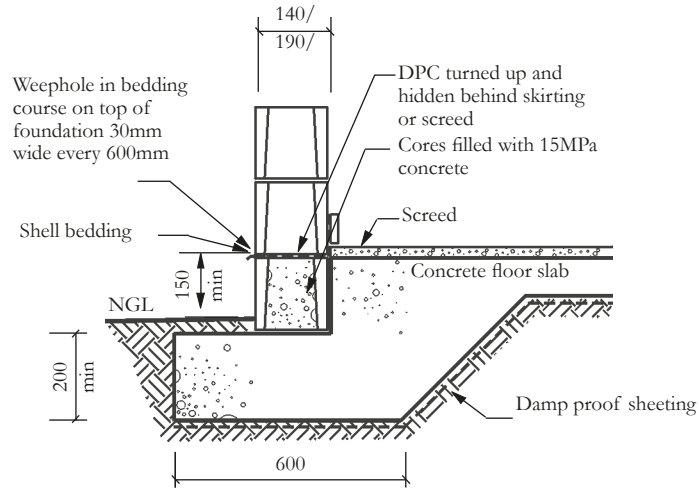

### THICKENED SLAB FOUNDATION

### H-FG-NB

**Note:**

1. Thickened slab foundations may cause cracking with ground floor slab. Consider use of fabric reinforcement in slab to limit cracking.
2. The bearing capacity and sensitivity to moisture changes of soil may be unsatisfactory with thickened slab foundations.
3. Refer to SANS 10161 for foundation sizes based on specific soil conditions and Home Building Manual.
4. Bond or U-blocks, without dampproof sheeting, may be used in place of traditional DPC's. The position of weepholes is changed – see details below. In all cases the mortar bedding is shell bedding with no mortar under webs.
5. Foundation material conditions will determine whether wall, concrete or steel columns share a common

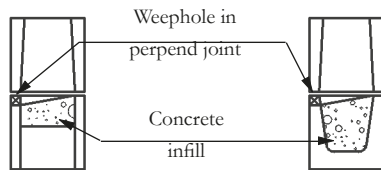

SECTION

SECTION

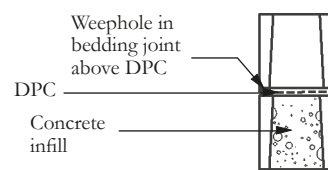

SECTION

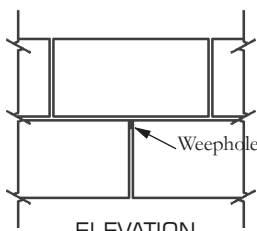

ELEVATION

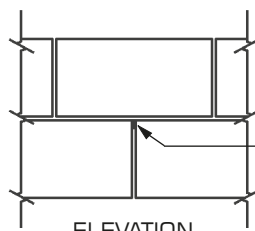

ELEVATION

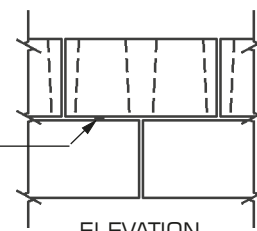

ELEVATION

### BOND BLOCK

### U-BLOCK

### HOLLOW BLOCK

foundation around the column foundation area. Estimates of likely settlement between wall and column will determine the need or otherwise for movement (control) joints in the wall.

# FOUNDATION AND WALL DETAILS – INTERNAL WALLS

**H-FG-05**

See H-FG-NB

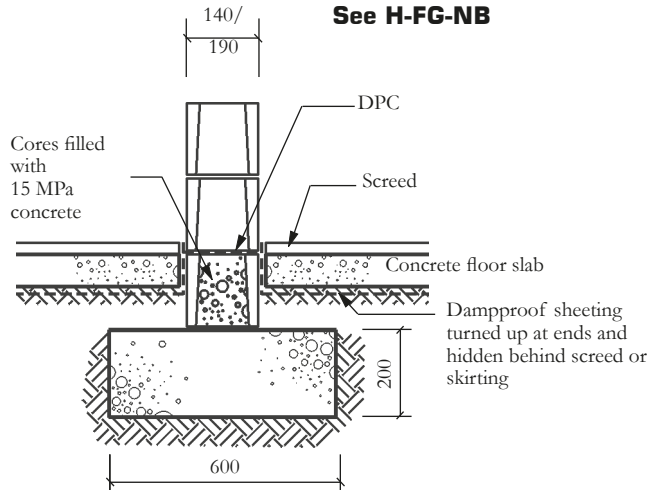

**STRIP FOUNDATION**

**H-FG-06**

See H-FG-NB

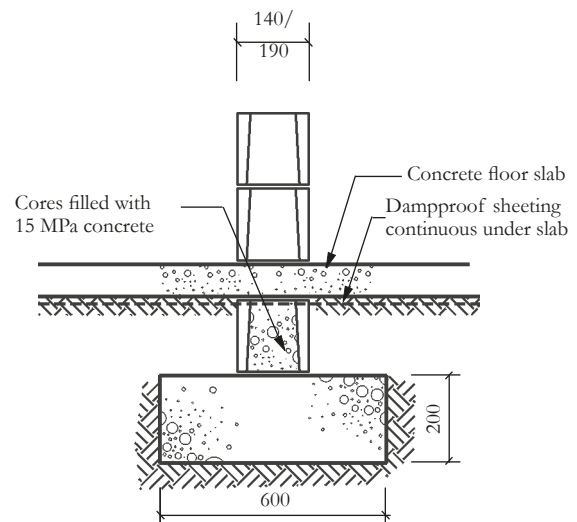

**STRIP FOUNDATION**

**H-FG-07**

See H-FG-NB

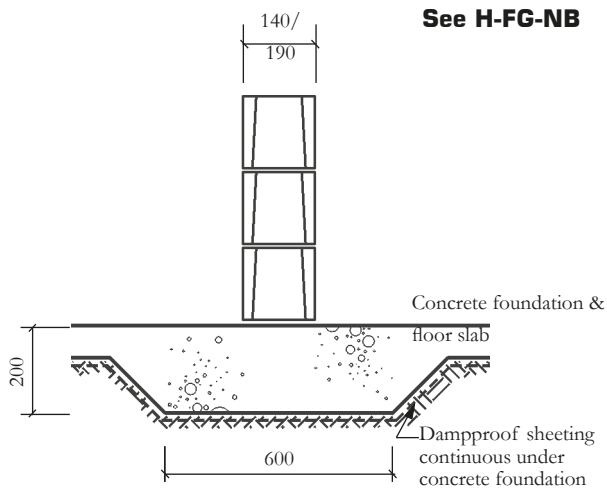

**THICKENED SLAB FOUNDATION**

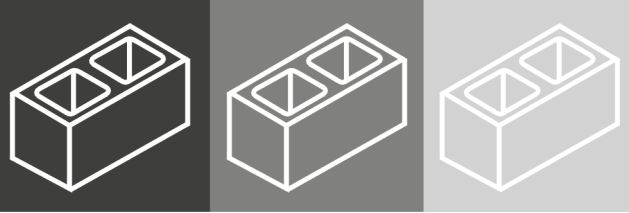

## SILLS AND LINTELS

### H-SI-01

See H-SI-NB

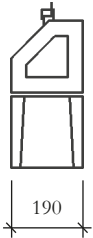

**190 SILL**

### H-SI-02

See H-SI-NB

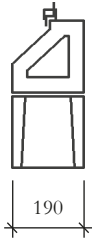

**'METAL WINDOW' SILL**

### H-SI-03

See H-SI-NB

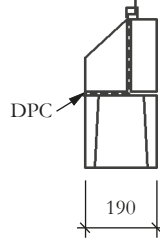

**DPC SILL**

### H-SI-04

See H-SI-NB

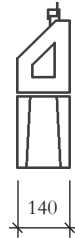

**140 SILL**

### H-SI-05

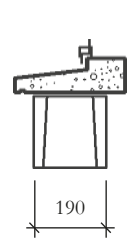

**PRECAST SILL**

### H-SI-NB

**Note:**

It is recommended that the external sloping face of masonry sills be painted with a clear coating of water repellent.

### H-LI-01

See H-LI-NB

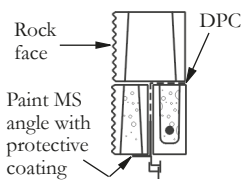

**ANGLE IRON/U BLOCK LINTEL**

### H-LI-02

See H-LI-NB

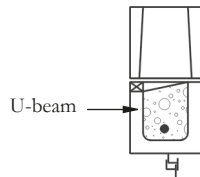

**U-BEAM LINTEL**

### H-LI-03

See H-LI-NB

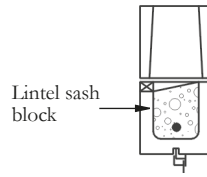

**SASH BLOCK LINTEL**

### H-LI-04

See H-LI-NB

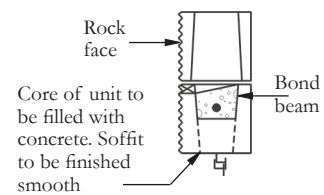

**BOND BLOCK LINTEL**

### H-LI-NB

**Note:**

1. Refer to CMA Design Guide and Technical Notes on lintels.
2. Units manufactured in different lengths
 

UNIT	LENGTHS
Lintel sash block	190mm
U-block	190/390mm
Rock face bond block	190/390mm
Fair face bond block	390mm

# WINDOW FRAME DETAILS – STEEL FRAMES

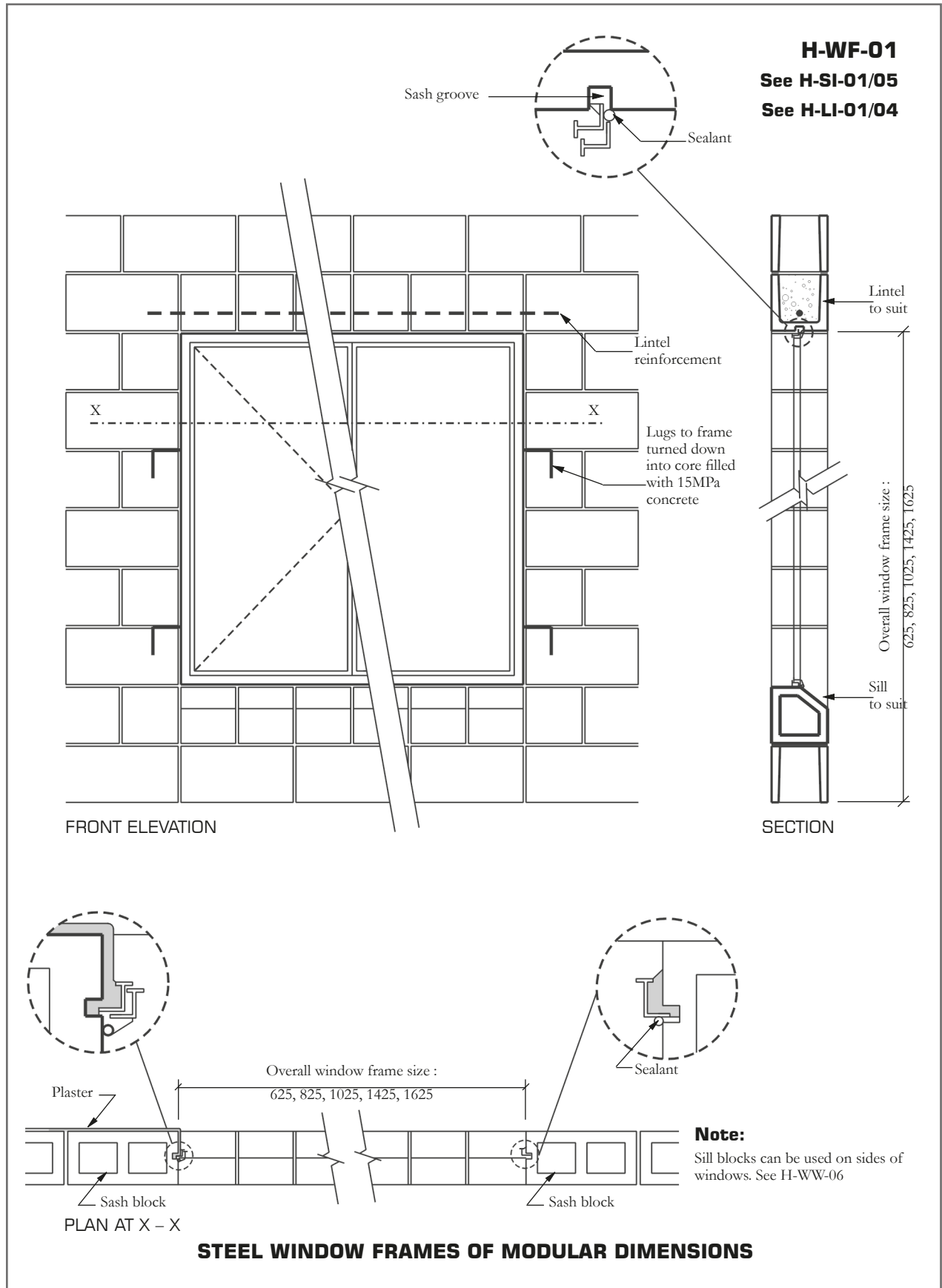

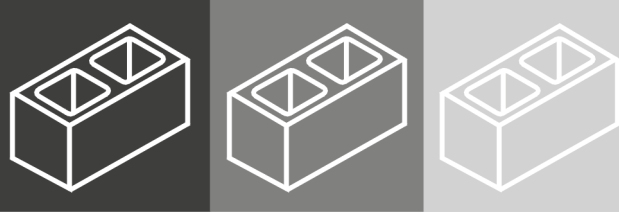

# WINDOW FRAME DETAILS – STEEL FRAMES

**H-WF-02**

See H-SI-01/05

See H-LI-01/04

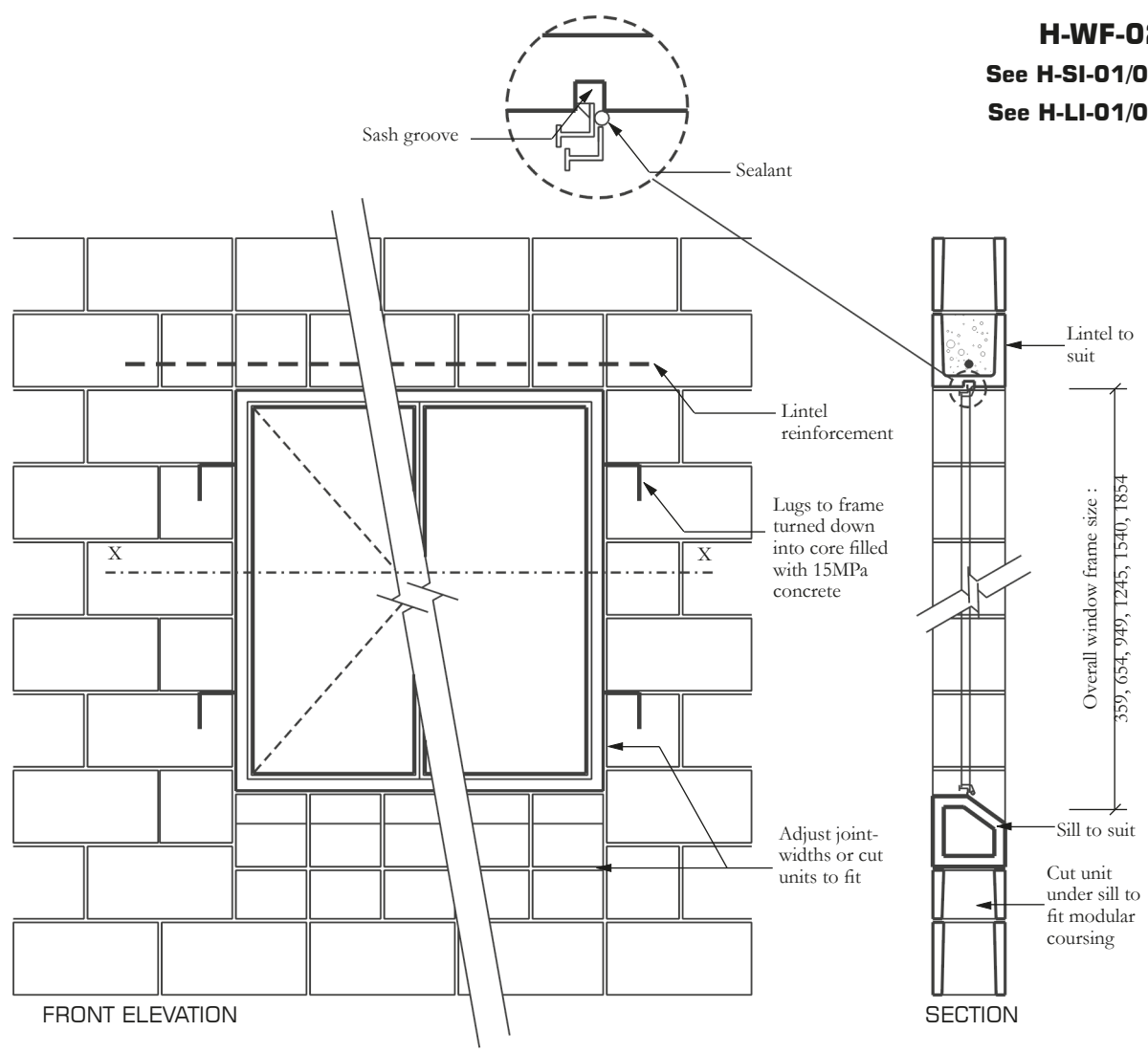

FRONT ELEVATION

SECTION

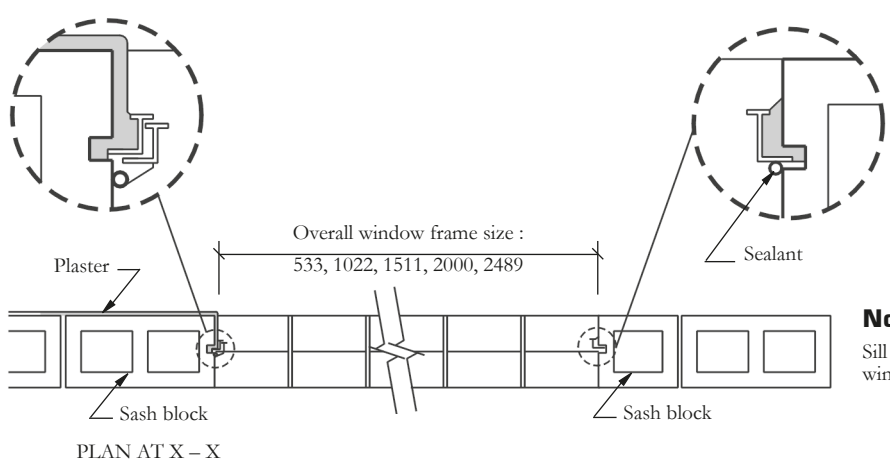

PLAN AT X - X

**Note:**  
Sill blocks can be used on sides of windows. See H-WW-06

## STEEL WINDOW FRAMES OF NON-MODULAR DIMENSIONS

# DOOR FRAME DETAILS – STEEL FRAMES

**H-DF-01**

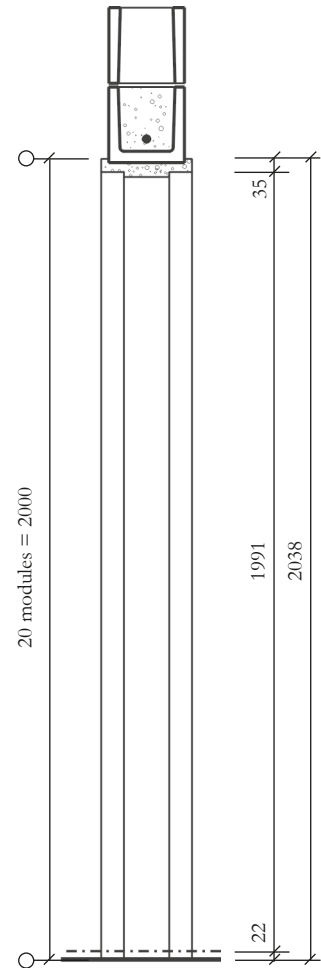
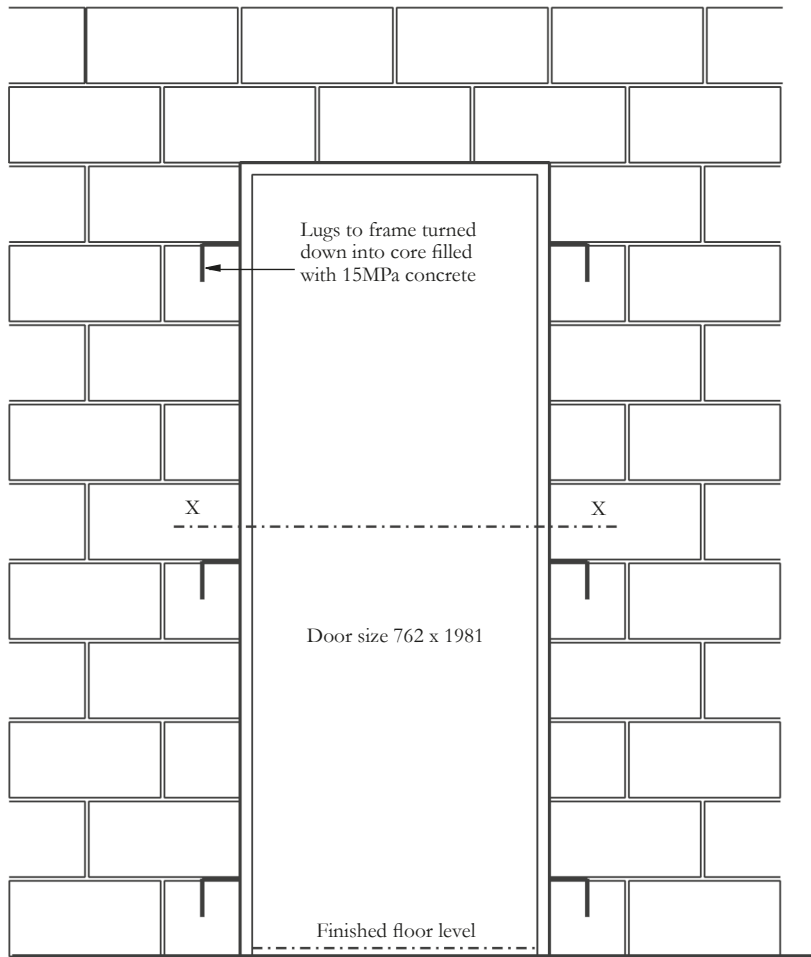

ELEVATION

SECTION

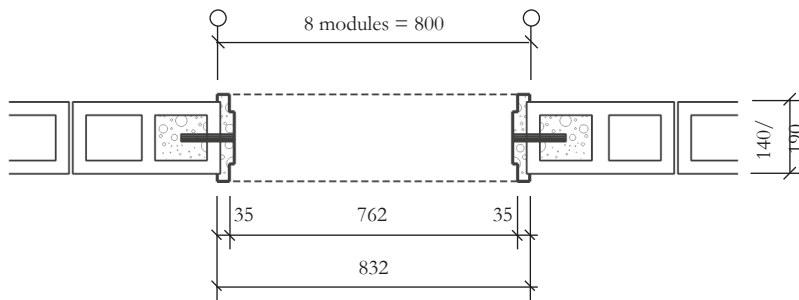

PLAN AT X - X

**STEEL DOOR FRAME 762 x 1981 TO FIT MODULAR SPACE 800 x 2000mm**

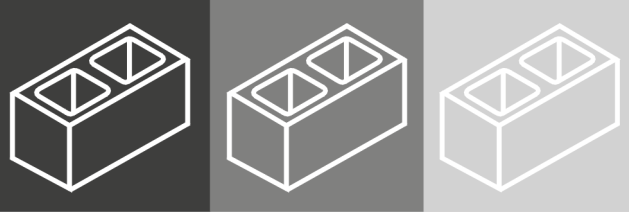

**DOOR FRAME DETAILS – STEEL FRAMES**

**H-DF-02**

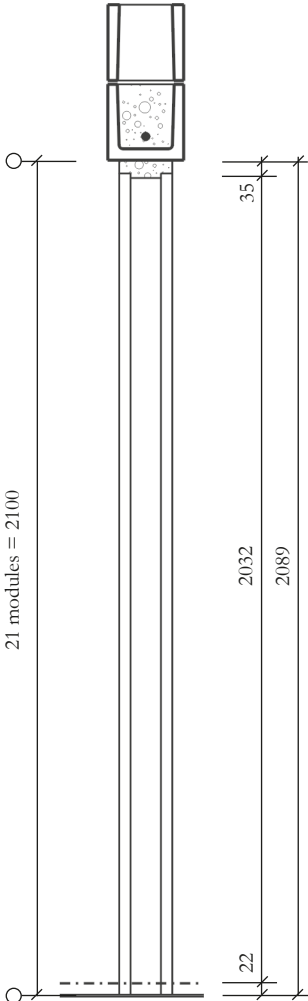
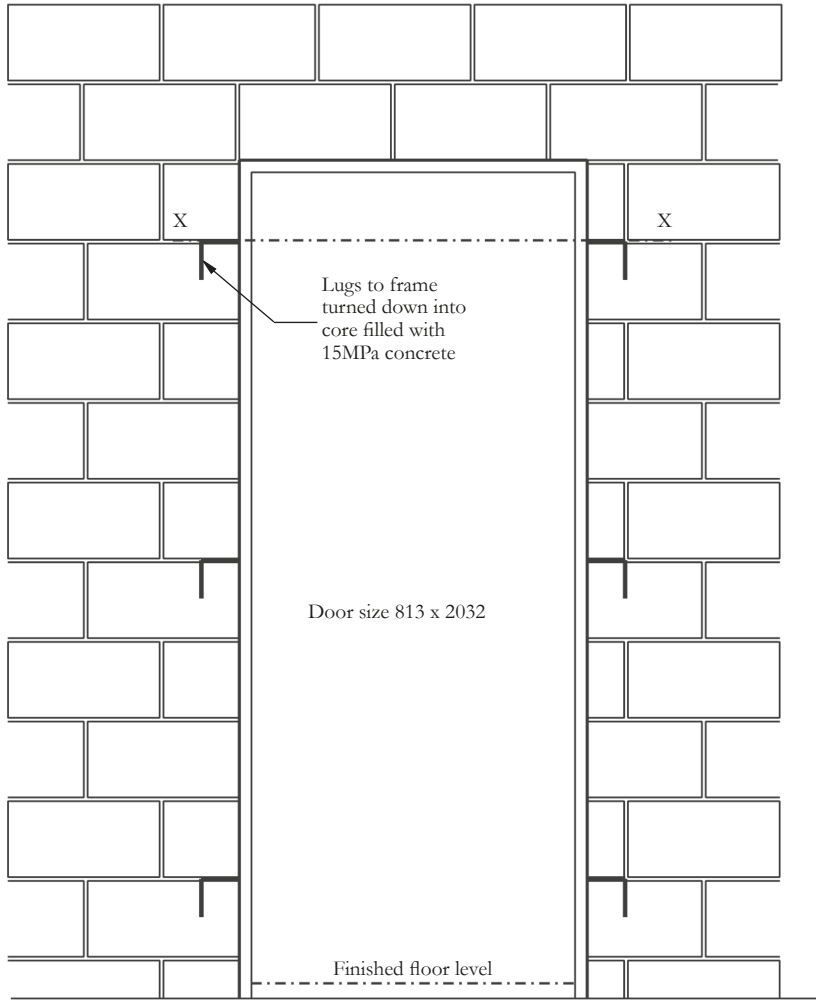

**SECTION**

Joint widths adjusted to fix door frame in masonry except for fluted or scored units where modular size frame required

**ELEVATION**

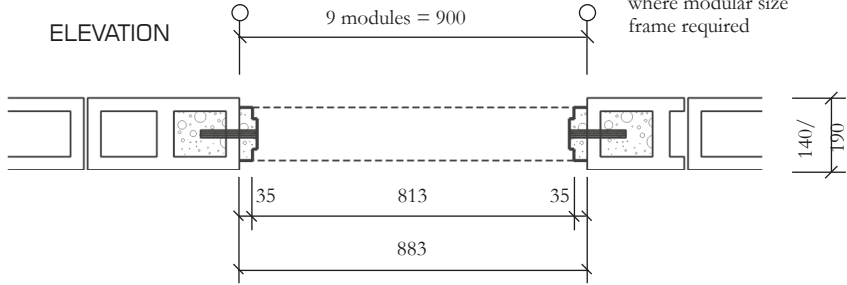

**PLAN AT X - X**

**STEEL DOOR FRAME 813 x 2032 TO FIT MODULAR SPACE 900 x 2100mm**

# DOOR FRAME DETAILS – ALUMINIUM FRAMES

**H-DF-03**

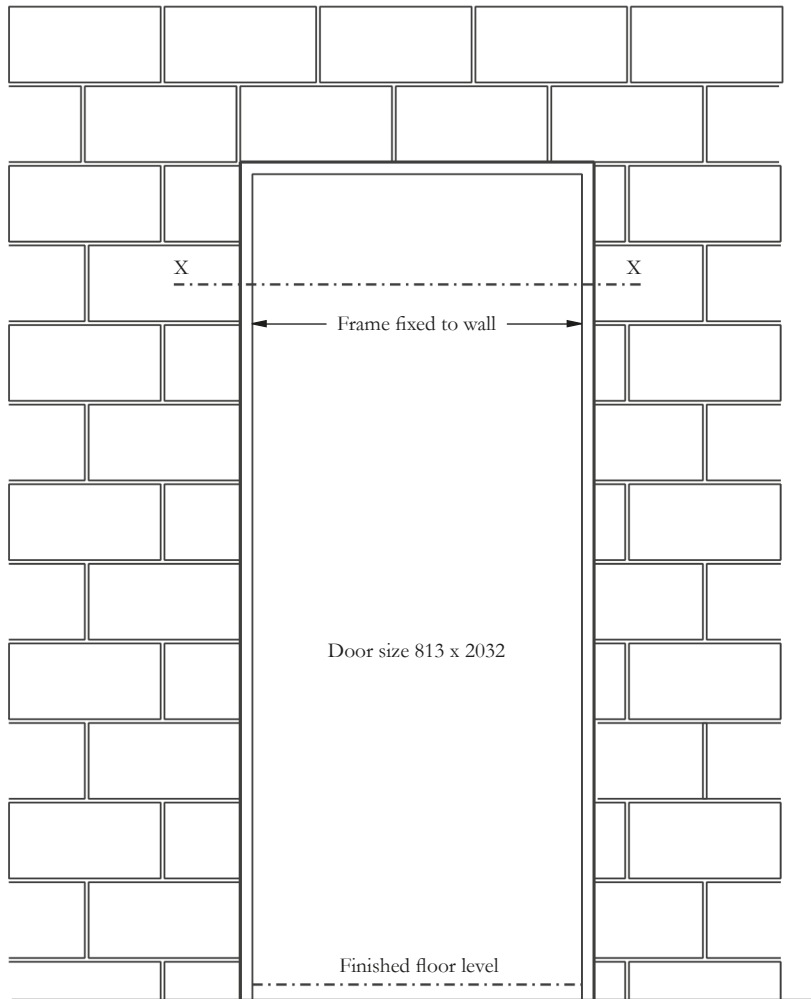

ELEVATION

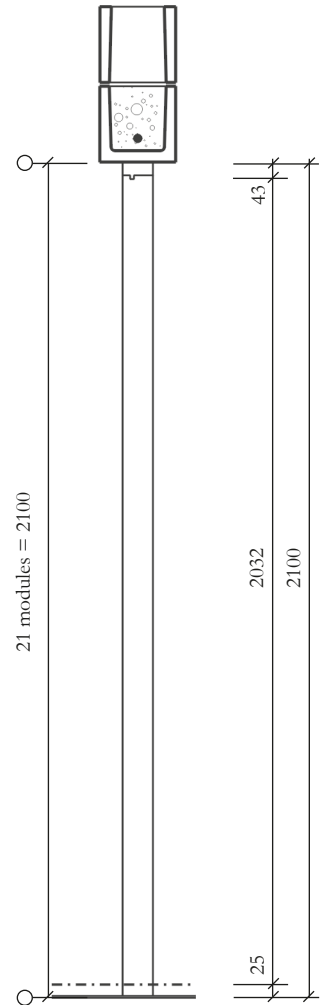

SECTION

Joint widths adjusted to fix door frame in masonry except for fluted or scored units where modular size frame required

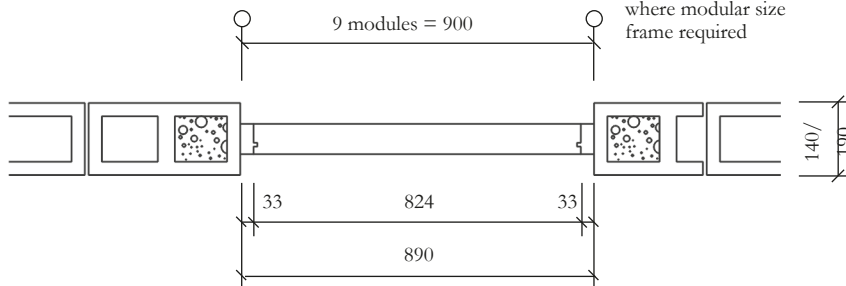

PLAN AT X - X

**ALUMINIUM DOOR FRAME 813 x 2032 TO FIT MODULAR SPACE 900 x 2100mm**

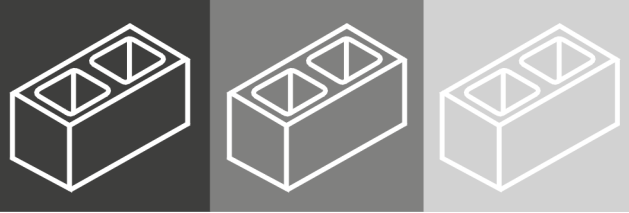

## INDEX TO SUSPENDED FLOORS ON EXTERNAL AND INTERNAL WALLS

Many factors influence the detail to be used at the junction of suspended concrete floors. Consideration should be given to the following:

### STRUCTURAL ASPECTS

- Is wall below slab structural or non-structural (i.e. infilling panel)?
- Is allowance to be made between top of supporting structural wall and slab for horizontal movement i.e. sliding? Or should there be fixity between wall and slab?

(Note: Sliding or fixity considerations are significant factors in design of both wall and slab)

### DETAILING ASPECTS

- Does suspended slab bear on full or part width of wall?
- Is exterior of wall face or plastered?
- Is damp proofing required?

SLAB BEARING	SLAB THICKNESS	FIXITY	WALL DETAILS			
			EXTERNAL		INTERNAL	
			STRUCTURAL	NON-STRUCTURAL	STRUCTURAL	NON-STRUCTURAL
SLAB ON PART WIDTH OF WALL	NON-MODULAR	SLIP PLANE	 H-SF-02 (190) H-SF-03 (140)			
	MODULAR	SLIP PLANE	 H-SF-04 (190) H-SF-05 (140)	 H-SF-10 (190)		
		FIXED	 H-SF-07			
SLAB ON FULL WIDTH OF WALL	NOT RELEVANT TO DETAIL	SLIP PLANE	 H-SF-01			
		LATERAL STABILITY		 H-SF-08 H-SF-09	 H-SF-11 H-SF-12 H-SF-13 H-SF-14	 H-SF-15 H-SF-16 H-SF-17
		FIXED	 H-SF-06			

# SUSPENDED FLOORS ON EXTERNAL WALLS

## H-SF-01

See H-SF-NB

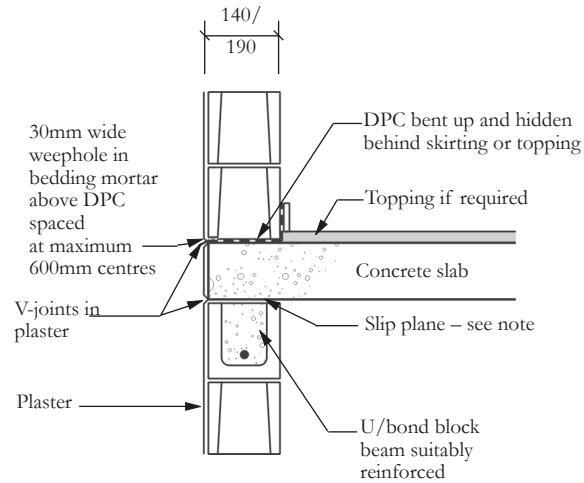

## PLASTERED STRUCTURAL WALL SUPPORTING SLAB

## H-SF-02

See H-SF-NB

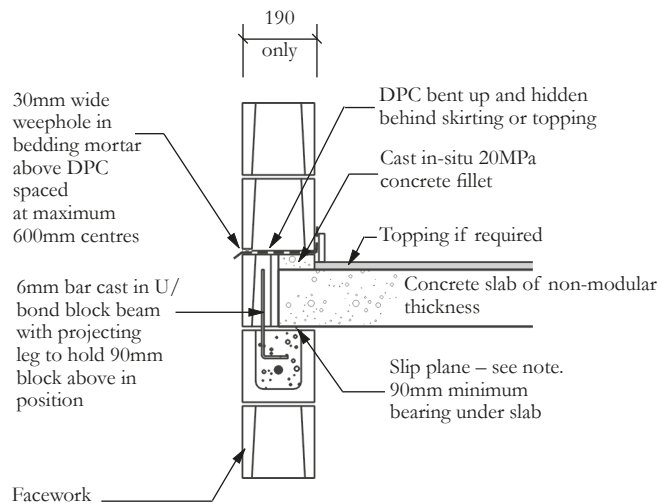

## FACE STRUCTURAL WALL SUPPORTING SLAB OF NON-MODULAR THICKNESS

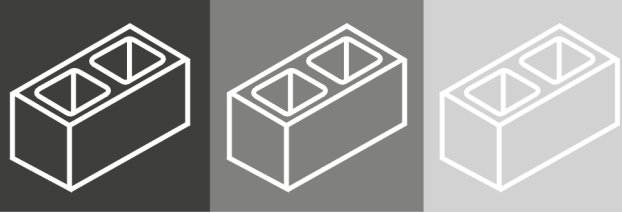

## SUSPENDED FLOORS ON EXTERNAL WALLS

**H-SF-03**

See H-SF-NB

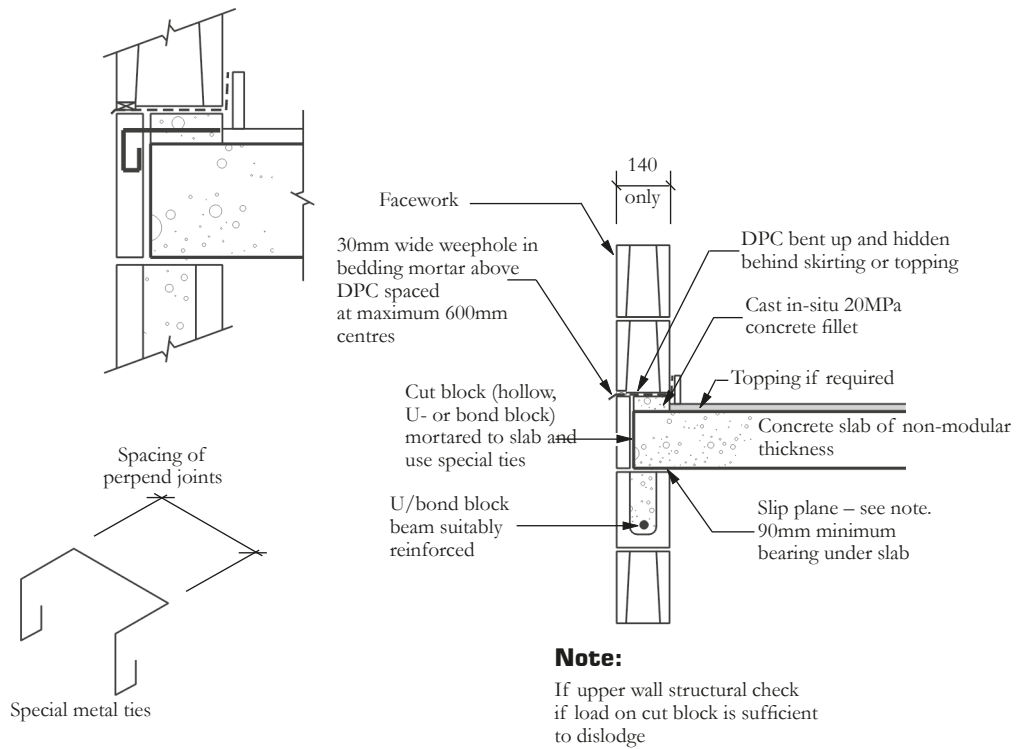

### FACE STRUCTURAL WALL SUPPORTING SLAB OF NON-MODULAR THICKNESS

**H-SF-NB**

**Note:**

1. If floor slab span exceeds 6m spanning on to wall and large movements expected consider a slip joint on top of wall, such as two layers of DPC or galv. sheet iron with grease between sheets or kilcher bearing or similar.
2. Structural stability & robustness may preclude use of slip joint.
3. If designer assumes wall laterally restrained by slab then slip joint not advisable.
4. Suspended floors either precast or cast-in-situ unless otherwise stated.
5. Where fixity required between slab and wall, reinforcement to be used to be determined by calculation.
6. Slabs of non-modular thickness require concrete infill (under modular size) or cut block (over modular size) to restore block coursing.

# SUSPENDED FLOORS ON EXTERNAL WALLS

## H-SF-04

See H-SF-NB

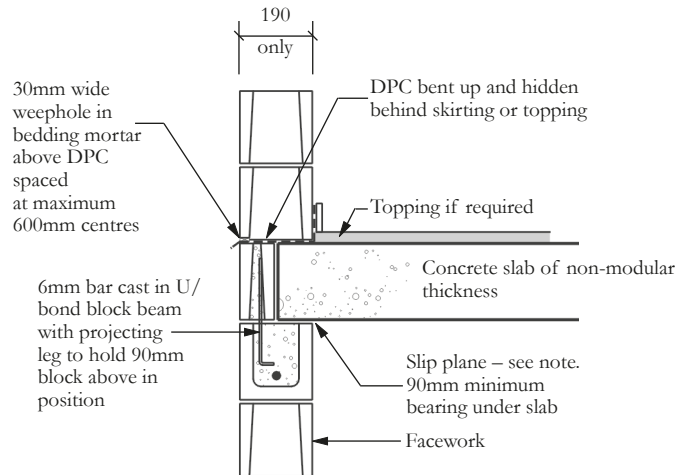

### FACE STRUCTURAL WALL SUPPORTING SLAB OF MODULAR THICKNESS

## H-SF-05

See H-SF-NB

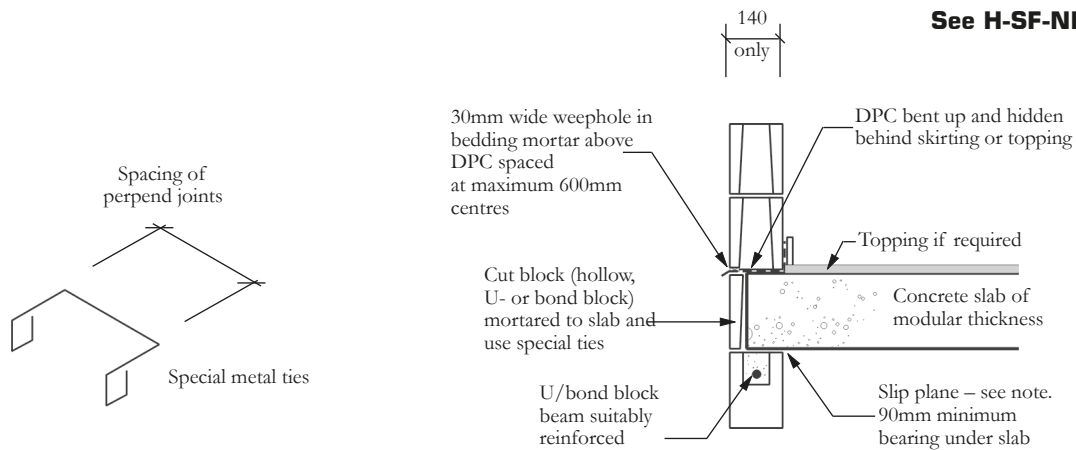

#### Note:

If upper wall structural check if load on cut block is sufficient to dislodge

### FACE STRUCTURAL WALL SUPPORTING SLAB OF MODULAR THICKNESS

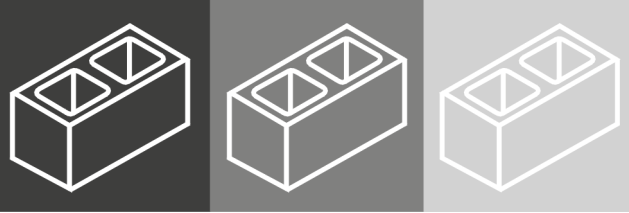

## SUSPENDED FLOORS ON EXTERNAL WALLS

**H-SF-06**

See H-SF-NB

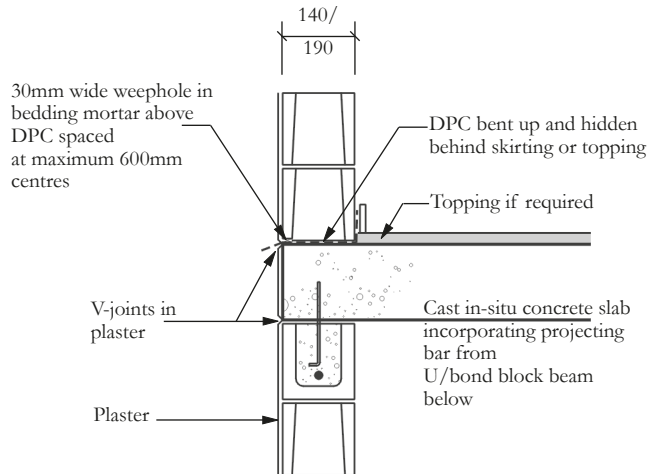

**PLASTERED STRUCTURAL WALL WHERE FIXITY BETWEEN WALL & SLAB REQUIRED**

**H-SF-07**

See H-SF-NB

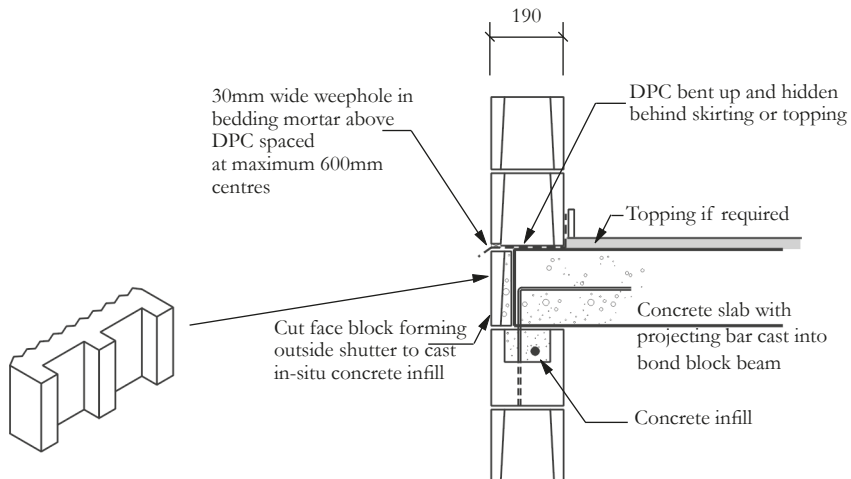

**FACE STRUCTURAL WALL WHERE FIXITY BETWEEN WALL & SLAB REQUIRED OF MODULAR THICKNESS**

# SUSPENDED FLOORS ON EXTERNAL WALLS

## H-SF-08

See App C

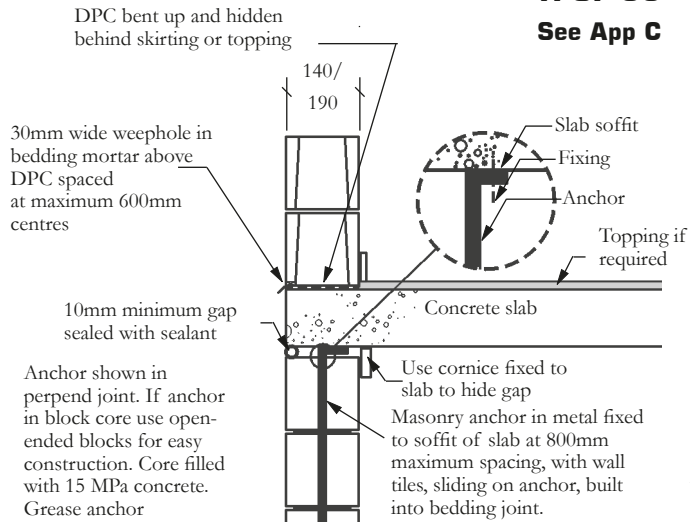

### Note:

Non-structural walls not to be built tight to underside of slab

## NON-STRUCTURAL INFILL PANEL WALL-LATERAL SUPPORT

## H-SF-09

See App C

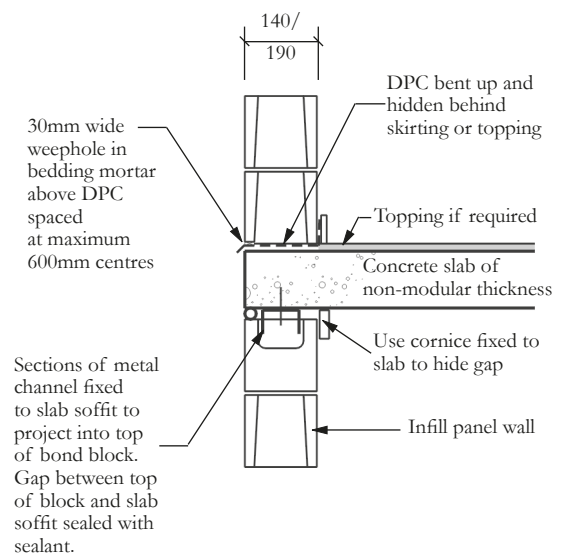

## NON-STRUCTURAL INFILL PANEL WALL-LATERAL SUPPORT

## H-SF-10

See App C

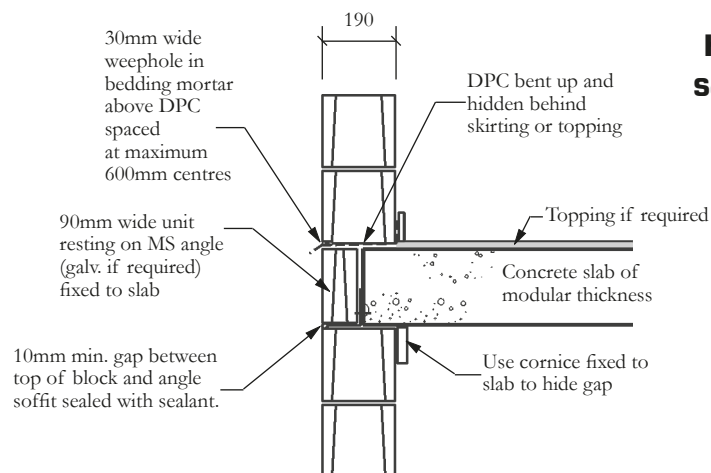

## FACE NON-STRUCTURAL INFILL PANEL WALL - NO LATERAL SUPPORT

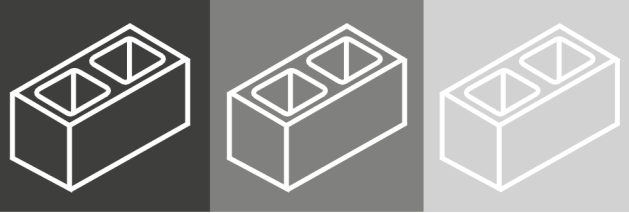

## SUSPENDED FLOORS ON INTERNAL WALLS

### H-SF-11

See H-SF-NB1

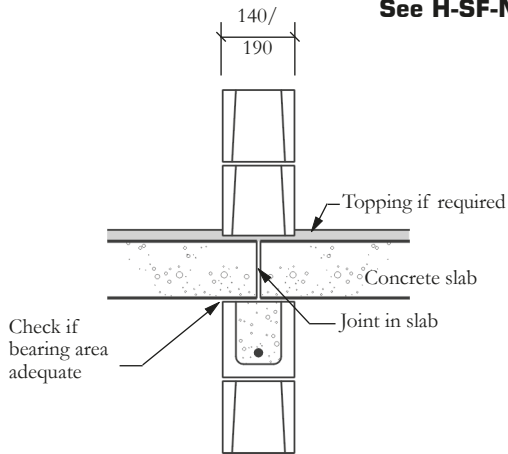

**STRUCTURAL WALL SUPPORTING JOINTED SLAB & WALL ABOVE**

### H-SF-12

See H-SF-NB1

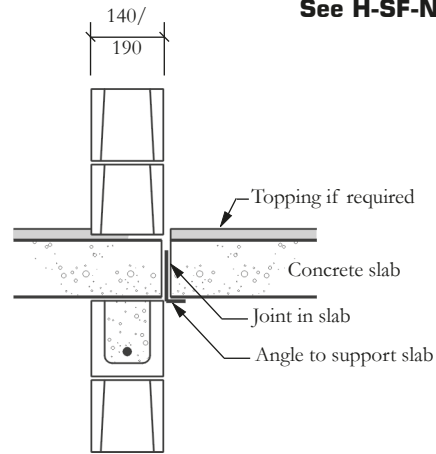

**STRUCTURAL WALL SUPPORTING JOINTED SLAB & WALL ABOVE**

### H-SF-13

See H-SF-NB1

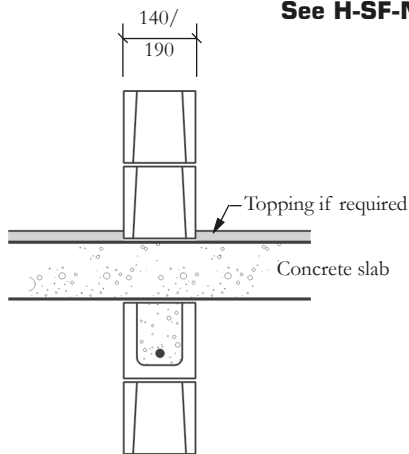

**STRUCTURAL WALL SUPPORTING CONTINUOUS SLAB & WALL ABOVE**

### H-SF-14

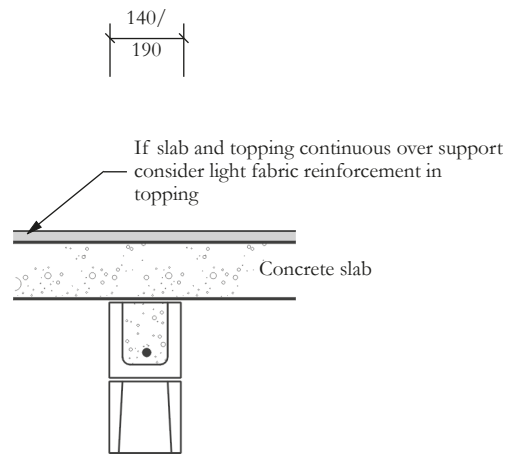

**STRUCTURAL WALL SUPPORTING SLAB ONLY**

### H-SF-NB1

**Note:**

If thickness of slab is not modular then concrete infill or cut blocks to be used in first course above slab to restore unit coursing to bond with external walls

# SUSPENDED FLOORS ON INTERNAL WALLS

**H-SF-15**  
See App C  
See H-SF-NB1

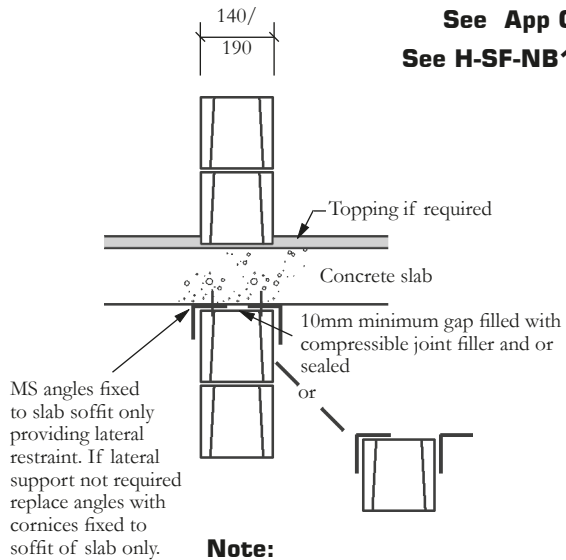

**NON-STRUCTURAL WALL WITH LATERAL SUPPORT AT SLAB SOFFIT**

**H-SF-16**  
See App C  
See H-SF-NB1

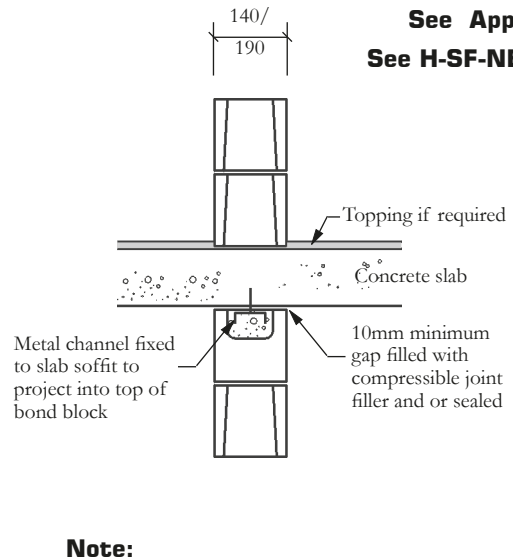

**NON-STRUCTURAL WALL WITH LATERAL SUPPORT AT SLAB SOFFIT**

**H-SF-17**  
See App C  
See H-SF-NB1

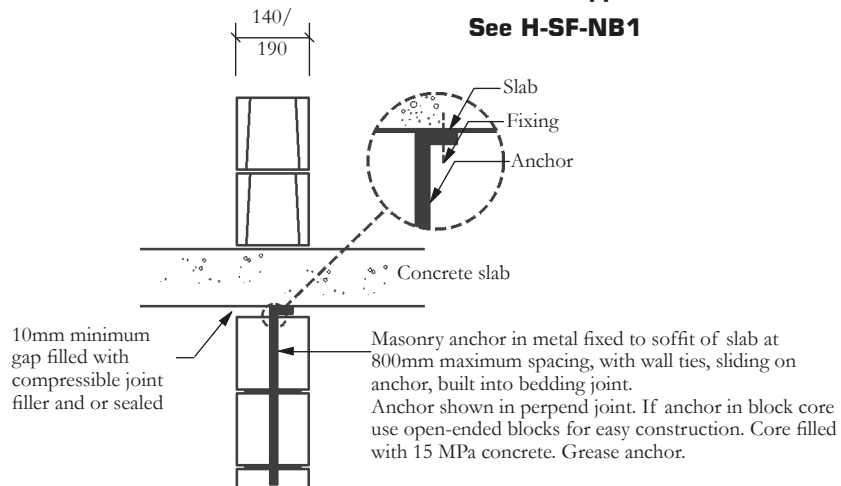

**NON-STRUCTURAL WALL WITH LATERAL SUPPORT AT SLAB SOFFIT**



# PARAPET WALLS, COPING & WATERPROOFING ROOF SLAB

## H-PW-01

See H-PW-NB

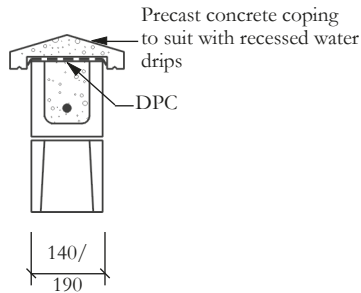

**PRECAST CONCRETE COPING ON BEAM**

## H-PW-02

See H-PW-NB

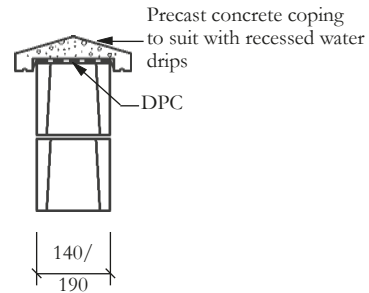

**PRECAST CONCRETE COPING ON MASONRY UNIT**

## H-PW-03

See H-PW-NB

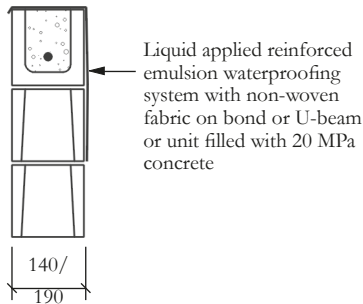

**LIQUID APPLIED WATERPROOFING SYSTEM**

## H-PW-04

See H-PW-NB

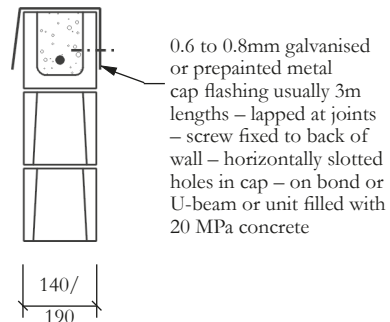

**METAL CAP**

**Note:**

It is recommended that the external sloping face of sill block be painted with a clear water repellent.

## H-PW-05

See H-PW-NB

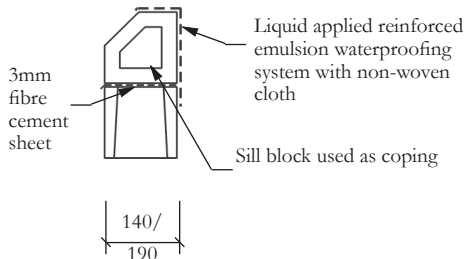

**MASONRY COPING**



## H-RS-01

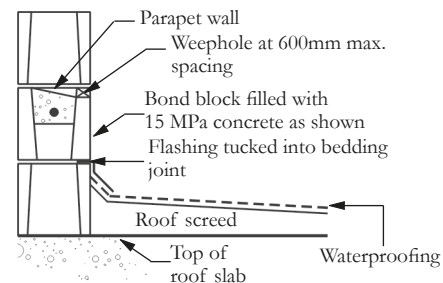

**Note:**

Details of junctions of roof slabs on walls are as for junctions of suspended slabs on walls

**WATERPROOFING - PARAPET WALLS / ROOF SCREEDS**

**Note:**

## H-PW-NB

1. Parapet walls to be designed for wind loading
2. Where conditions are such that the coping is likely to be dislodged some mechanical fixing of coping to wall to be considered
3. Parapet walls to be designed to accommodate horizontal movements whilst maintaining structural stability

# ROOF TRUSS FIXING TO WALL

## H-RT-01

See App D  
See H-RT-04

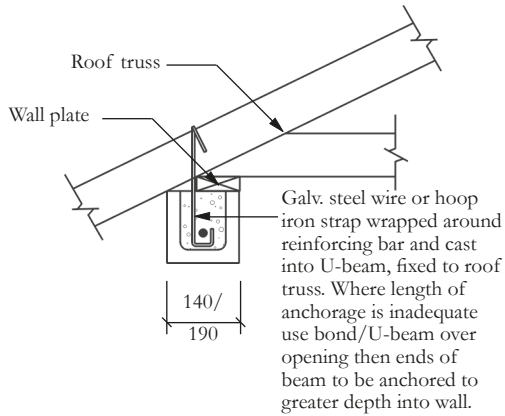

**ROOF ANCHORAGE TO BEAM**

## H-RT-02

See App D

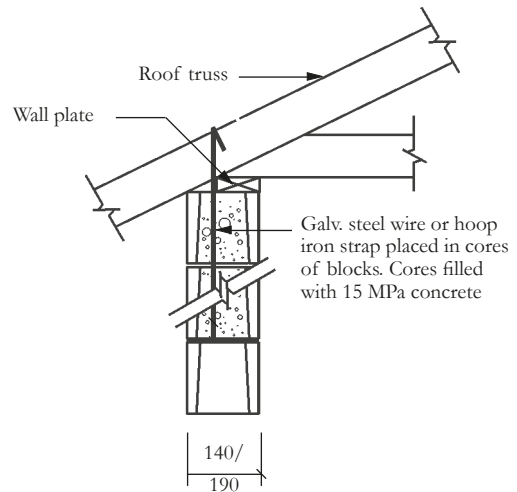

**ROOF ANCHORAGE TO WALL**

## H-RT-03

See App D

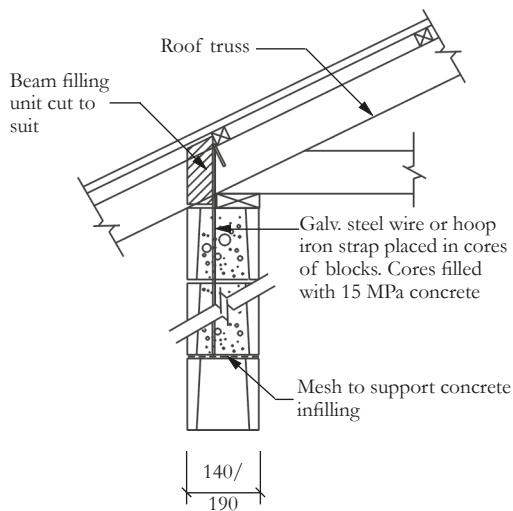

**BEAM FILLING**

## H-RT-04

See App D

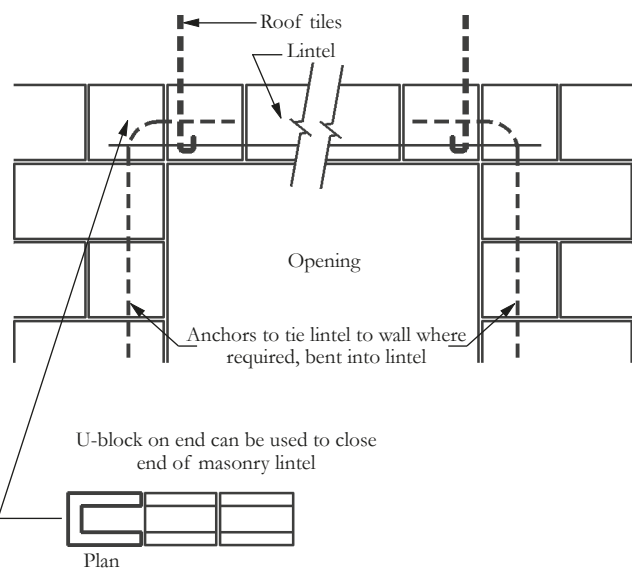

**ANCHORING ROOF TRUSSES OVER OPENINGS**



# MASONRY BOND PATTERNS AND JOINT PROFILES

**H-BP-01**

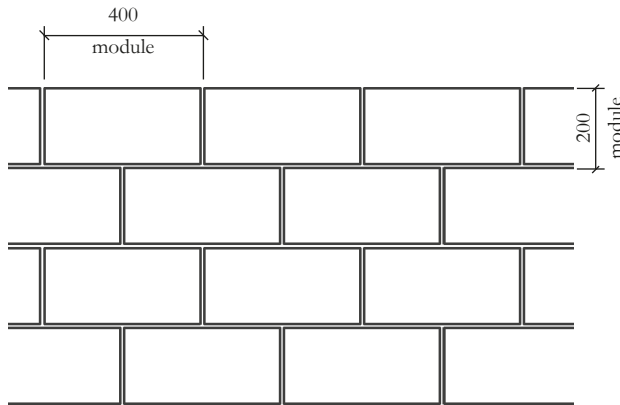

**STRETCHER OR RUNNING BOND**

**H-BP-02**

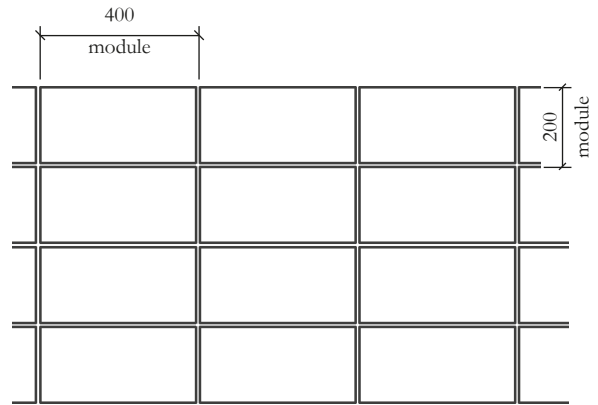

**STACK BOND**

**H-BP-03**

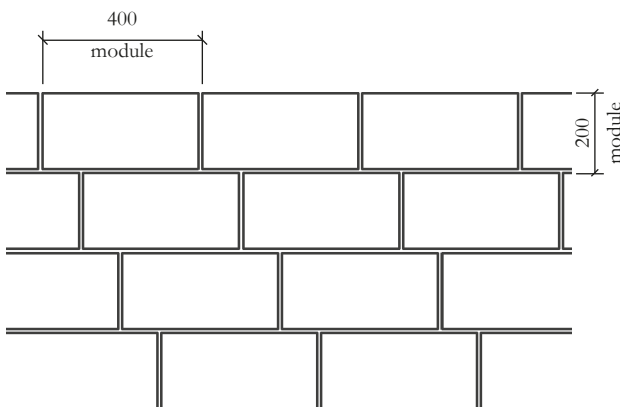

**QUARTER BOND**

**H-BP-04**

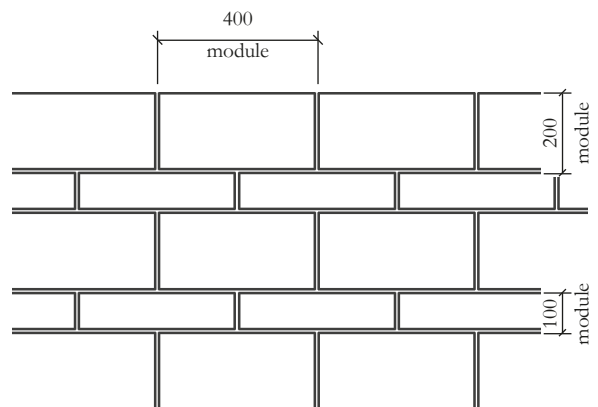

**COURSED ASHLAR BOND**

**H-BP-05**

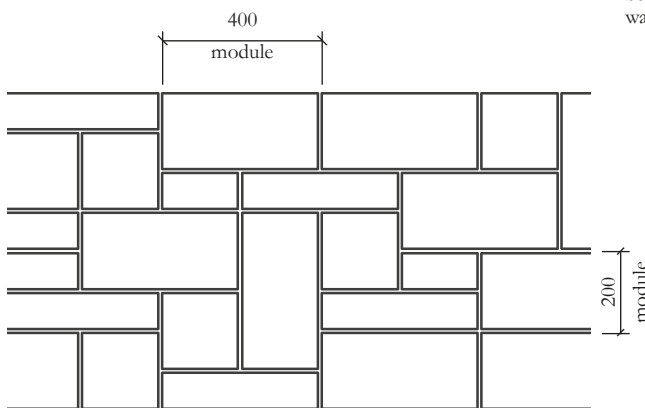

**ASHLAR BOND**

**H-BP-06**

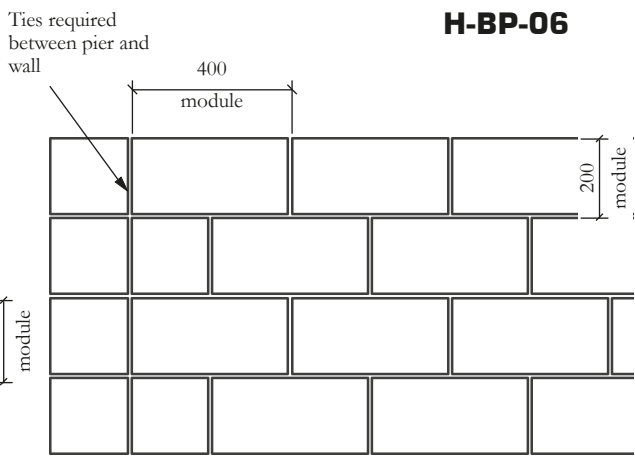

**STRETCHER BOND WITH  
STACK BOND PIER**

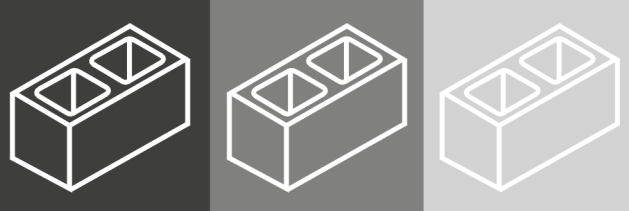

# MASONRY BOND PATTERNS AND JOINT PROFILES

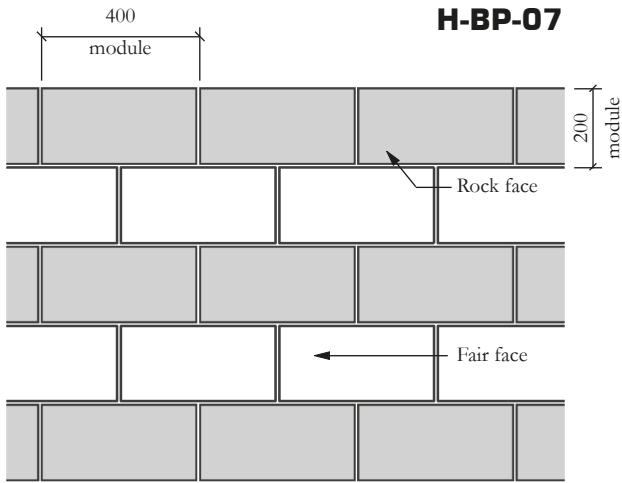

**BANDING**

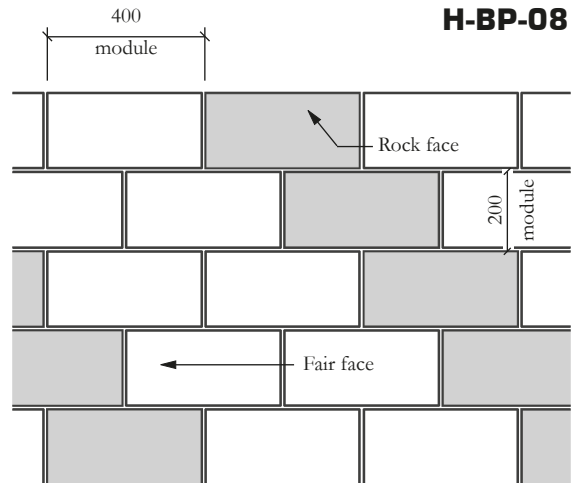

**DIAGONAL PATTERN**

For 10mm joint use 12mm ruling tool

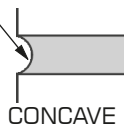

CONCAVE

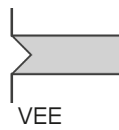

VEE

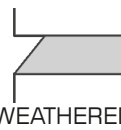

WEATHERED

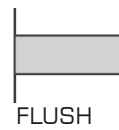

FLUSH

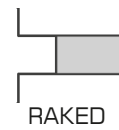

RAKED

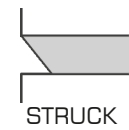

STRUCK

\* GOOD PRACTICE

\* FAIR PRACTICE

\* POOR PRACTICE

**Note:**

With plastered walls a recessed joint to assist bonding of plaster to walls is preferable.

**JOINT PROFILES FOR EXTERNAL WALLS SUBJECT TO WEATHER**

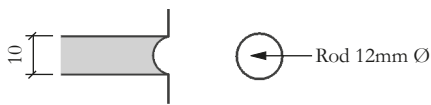

Fair face masonry with joint widths 10mm use 12mm Ø rod to rule joints when mortar thumb print hard. Rockface masonry with joint width 10mm use 9mm Ø rod to rule joints.

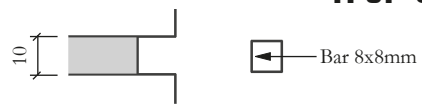

Fluted and scored rockface masonry with joint widths 10mm use 8x8mm square bar to rule joints when mortar thumb print hard. If concave joint profile required use 8mm Ø rod

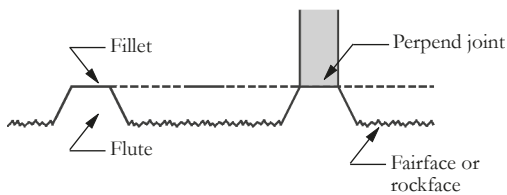

PLAN: FLUTED UNIT

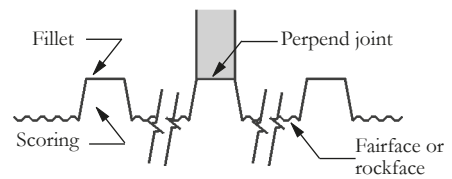

PLAN: SCORED UNIT

Fluted or scored units joint profile square and finished to fillet of fluting or scoring, unless otherwise specified

**FINISHING OF BEDDING AND PERPEND JOINTS**

## WALL TO WALL INTERSECTIONS – CORNERS

**H-WW-01**

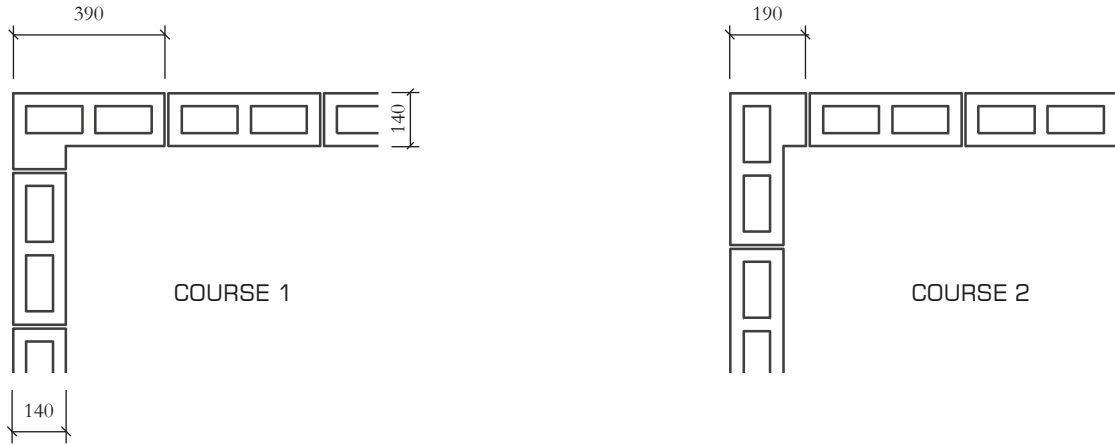

**140mm WALL: 400mm HORIZONTAL MODULE**

**H-WW-02**

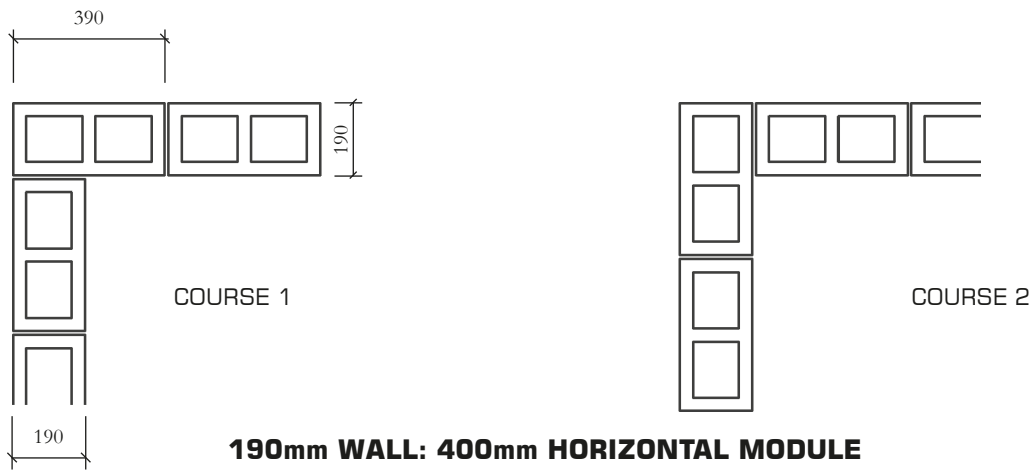

**190mm WALL: 400mm HORIZONTAL MODULE**

**H-WW-03**

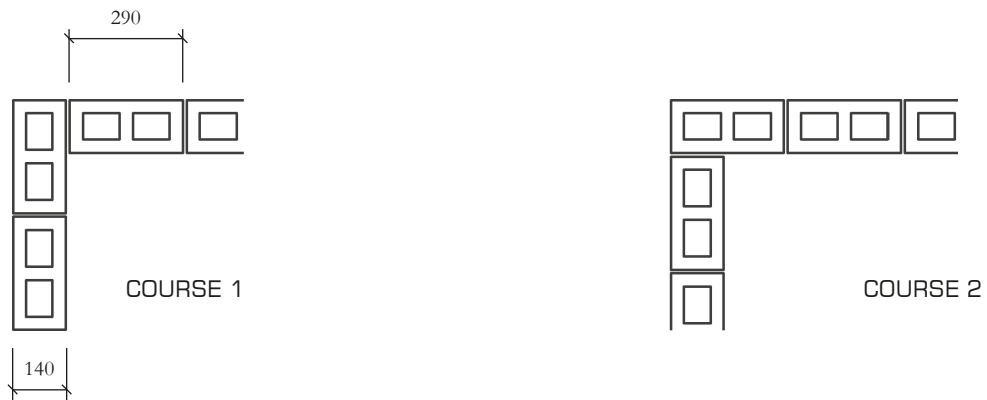

**140mm WALL: 300mm HORIZONTAL MODULE**

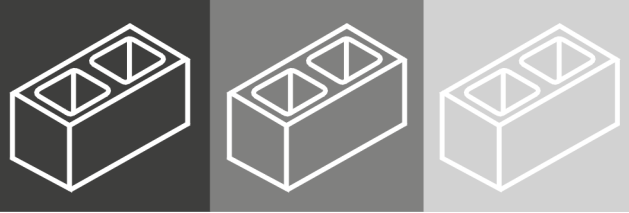

## WALL TO WALL INTERSECTIONS – FACE UNITS

**H-WW-04**

See H-JP-02

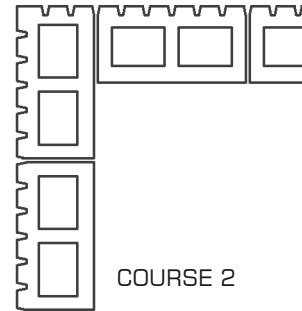
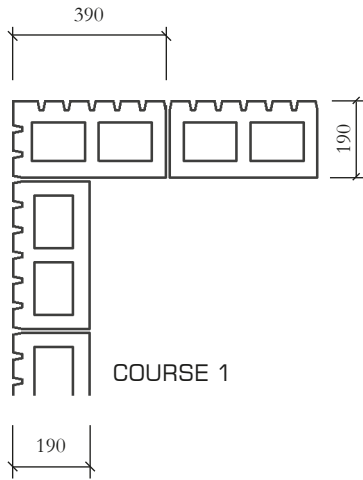

### FACE UNITS: EXTERIOR

**Note:**

Bedding and perpend joint profiles, mortar – colour and texture – to suit profile, colour and texture of unit

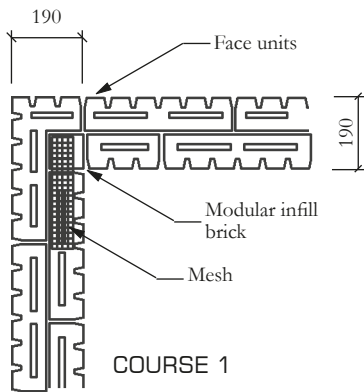

**H-WW-05**

See H-JP-02

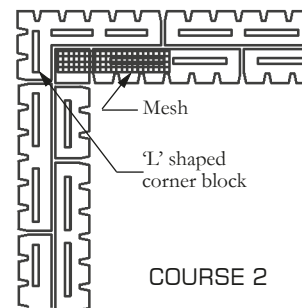

**Note:**

Bedding and perpend joint profiles, mortar – colour and texture – to suit profile, colour and texture of unit

### FACE UNITS: INTERIOR AND EXTERIOR

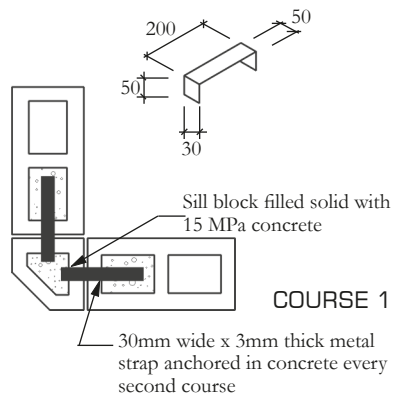

**H-WW-06**

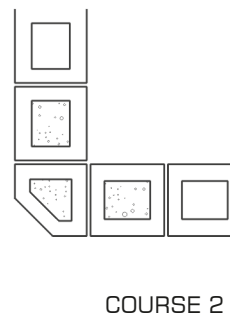

### SILL BLOCK FORMING CORNER

# WALL INTERSECTIONS

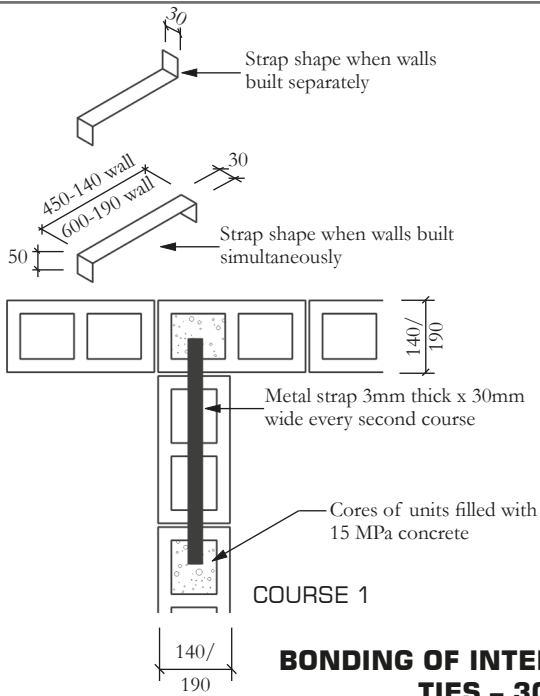

**H-WW-07**

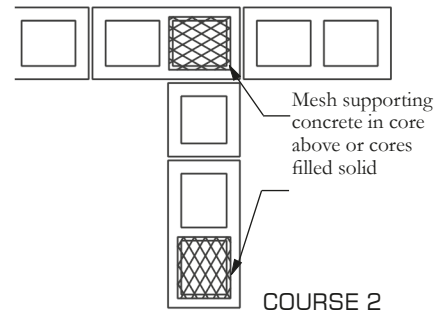

**BONDING OF INTERSECTING STRUCTURAL WALLS WITH TIES - 300mm AND 400mm MODULE**

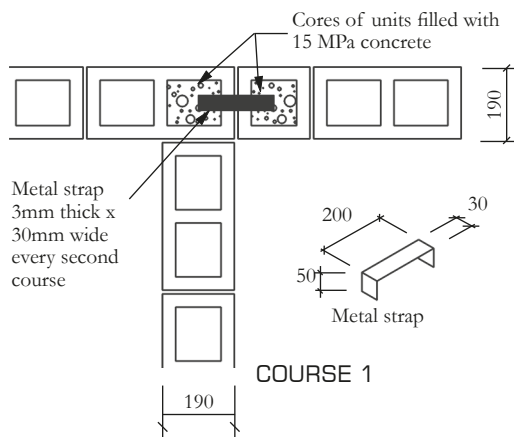

**H-WW-08**

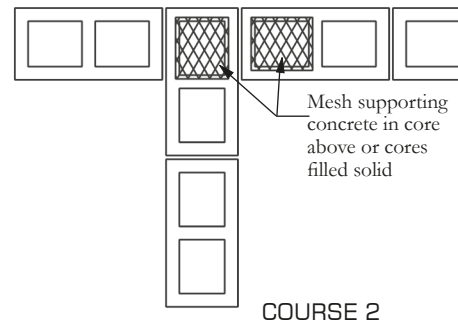

**BONDING OF INTERSECTING STRUCTURAL WALLS OF SAME THICKNESS - 400mm MODULE**

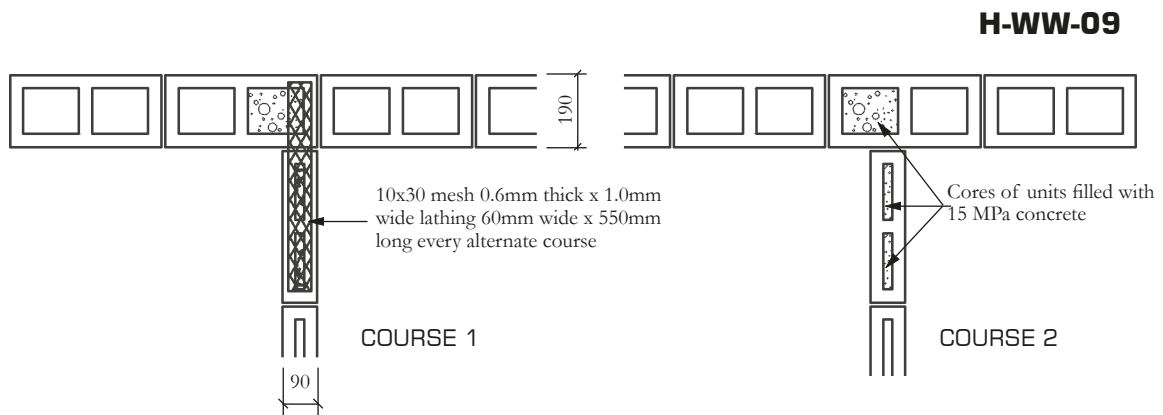

**H-WW-09**

**BONDING OF NON-STRUCTURAL WALLS**

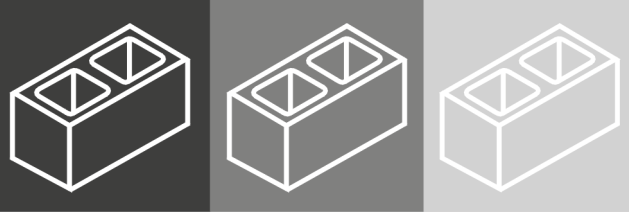

**PIER IN WALLS – FAIR-FACE UNITS – 300 MODULE**

**H-CM-01**

See H-CM-NB

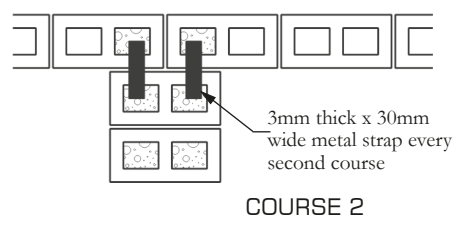
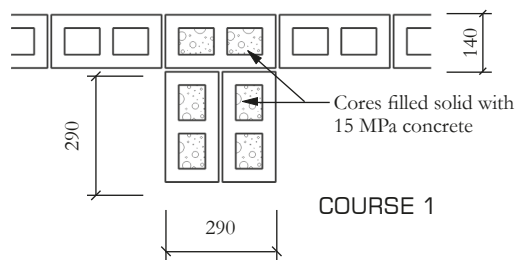

**290mm WIDE PIER 290mm PROJECTION – 140mm WALL, 300mm MODULE**

**H-CM-02**

See H-CM-NB

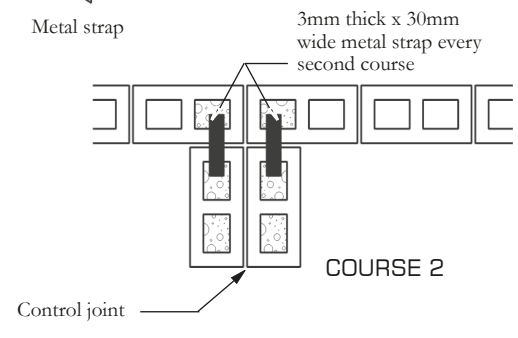
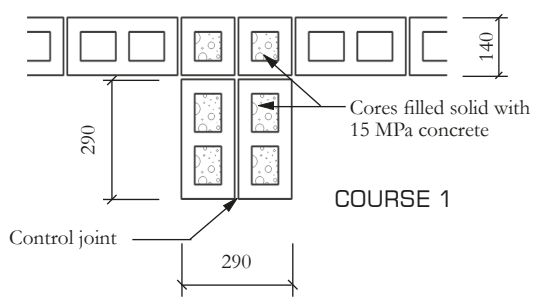
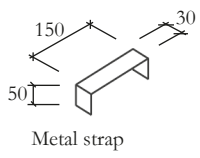

**290mm WIDE PIER 290mm PROJECTION – 140mm WALL, 300mm MODULE WITH CONTROL JOINT**

## PIER IN WALLS – FAIR-FACE UNITS – 400 MODULE

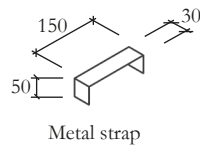

**H-CM-03**  
See H-CM-NB

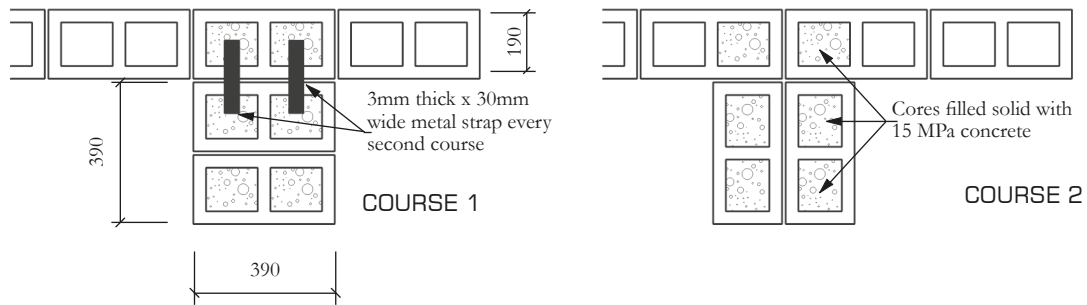

**390mm WIDE PIER 390mm PROJECTION – 190mm WALL, 400mm MODULE**

**H-CM-04**  
See H-CM-NB

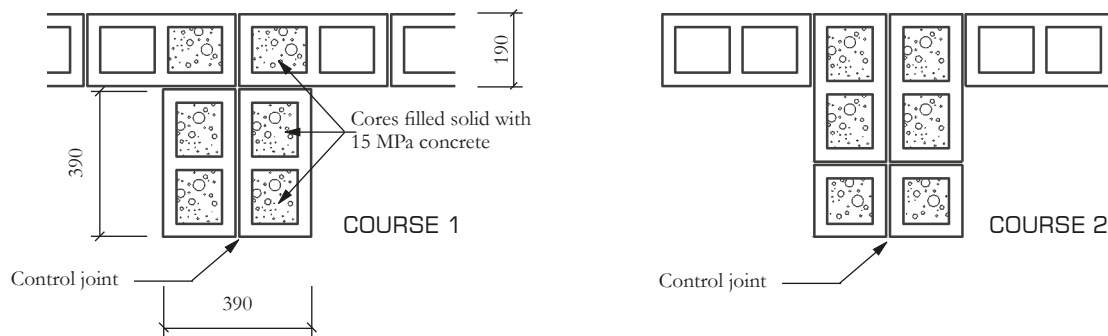

**390mm WIDE PIER 390mm PROJECTION – 190mm WALL, 400mm MODULE WITH CONTROL JOINT**

**Note:**

**H-CM-NB**

- At the end of a free-standing wall the pier width and projection must be of the same dimension as internal piers. The two adjacent piers at control joints must together be of the same overall dimension as an internal pier.

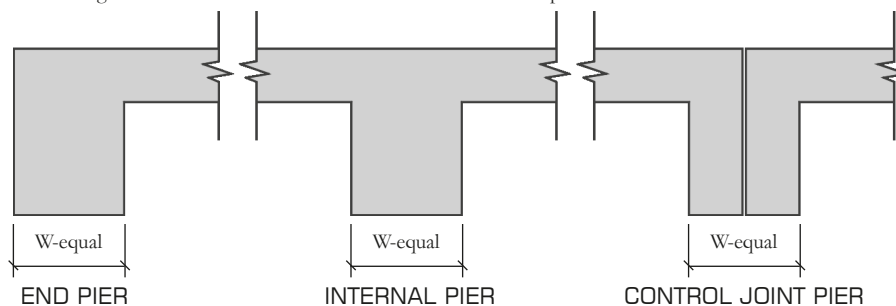

- The thickness of the wall shown is that at the base and may be reduced nearer the top of the wall. See SANS 10400-K – Free Standing Walls
- Refer to CMA Design Guide on Free Standing Walls, and SANS 10400-K

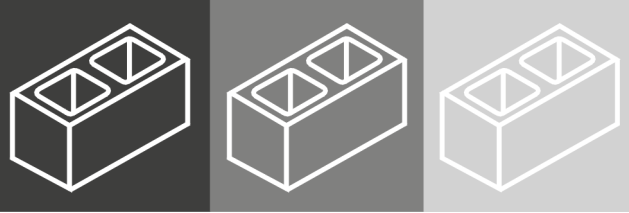

# PIER IN WALLS – ROCK FACE UNITS

**H-CM-05**  
See H-CM-NB

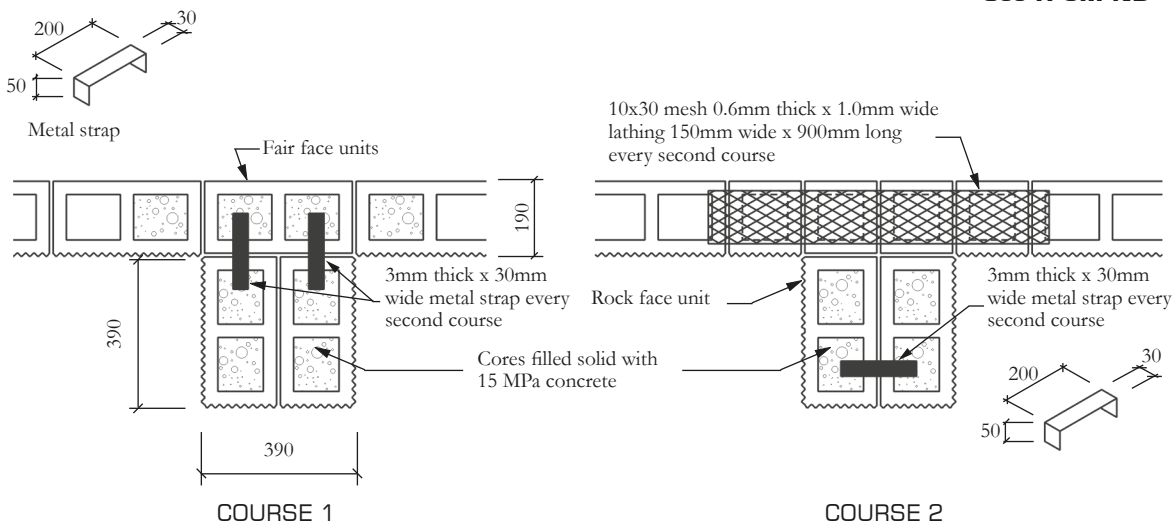

**390mm WIDE PIER 390mm PROJECTION – 190mm WALL, 400mm MODULE – FACE UNITS**

**H-CM-06**  
See H-CM-NB

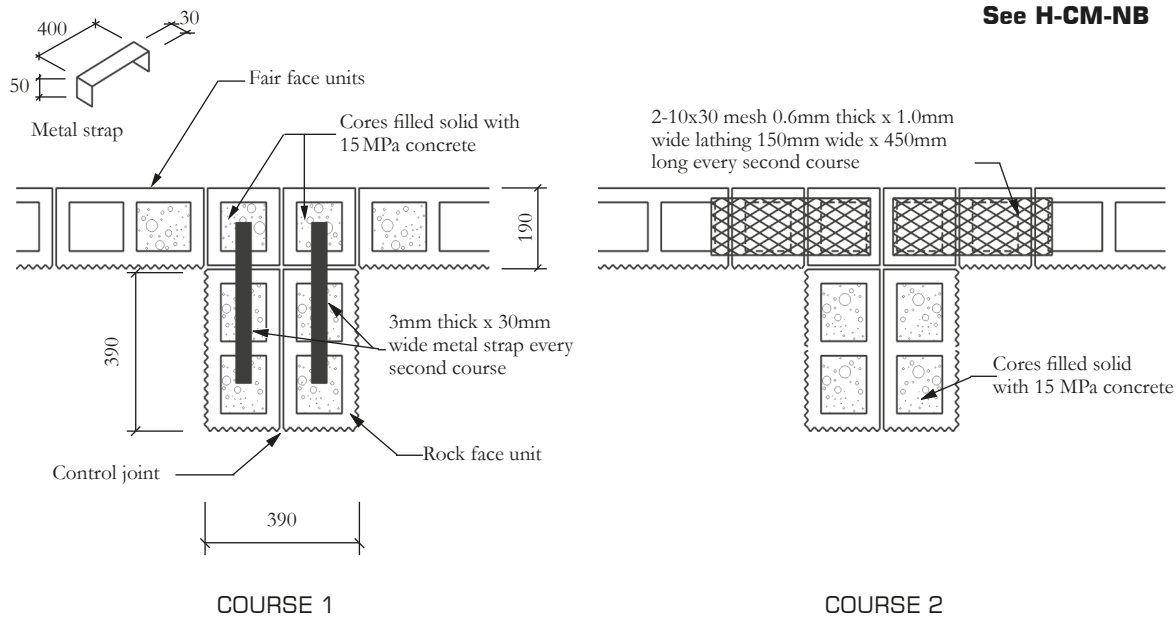

**390mm WIDE PIER 390mm PROJECTION – 190mm WALL, 400mm MODULE WITH CONTROL JOINT – FACE UNITS**

## PILASTER AND PIER BLOCKS IN WALLS

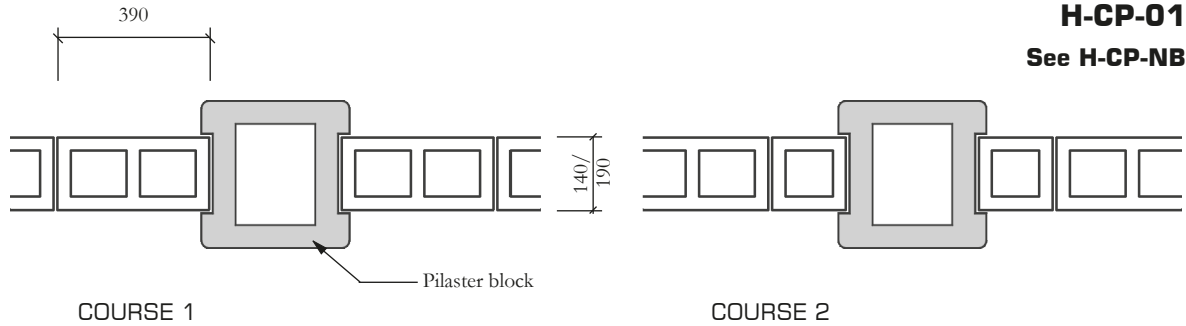

**PILASTER BLOCK IN WALL**

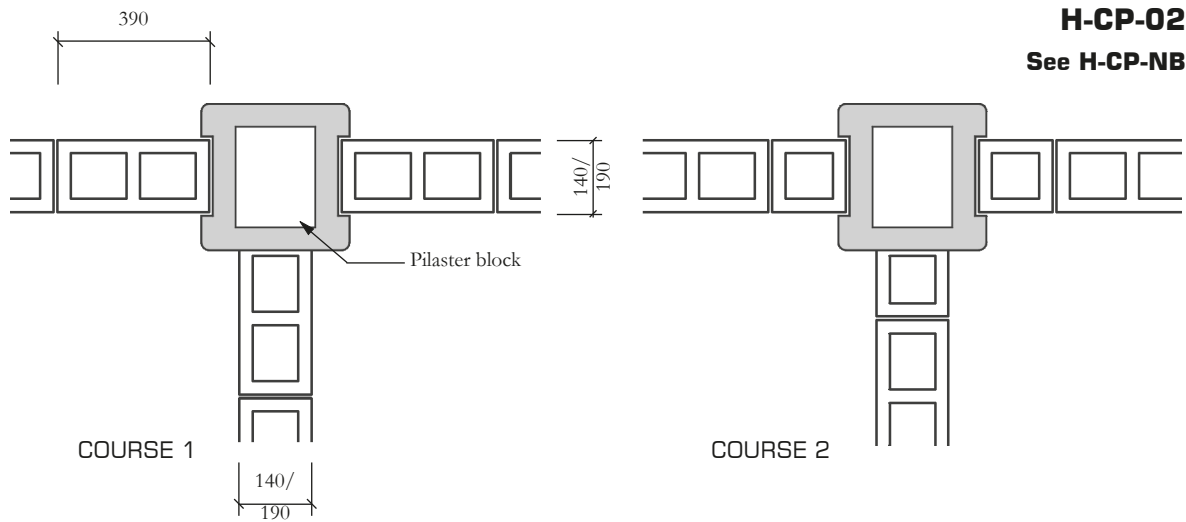

**PILASTER BLOCK AT T-JUNCTIONS**

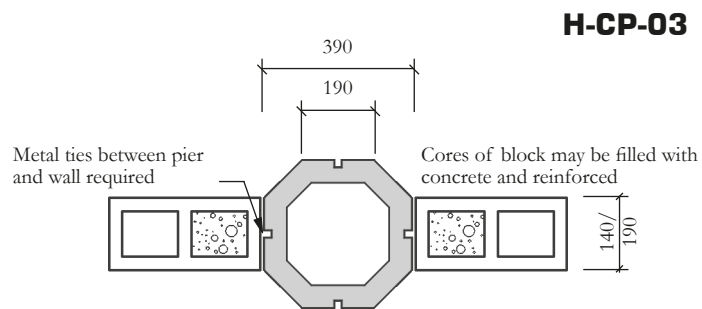

**OCTAGON SHAPED PIER BLOCK**

**H-CP-NB**

**Note:**

1. Pilaster blocks provide lateral support while permitting longitudinal movement, provided no metal ties are used between wall and pilaster block.
2. Pilaster block shape adjusted to suit number of intersecting walls and aesthetic considerations.
3. Pilaster blocks may be filled with concrete and reinforced if required.

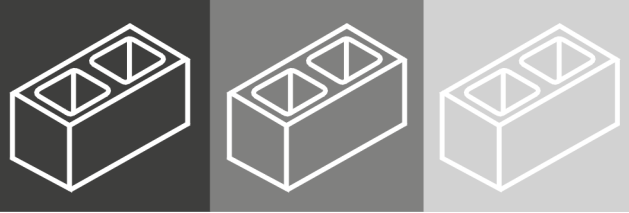

## CONCRETE COLUMN/WALL INTERSECTIONS

**H-CC-01**

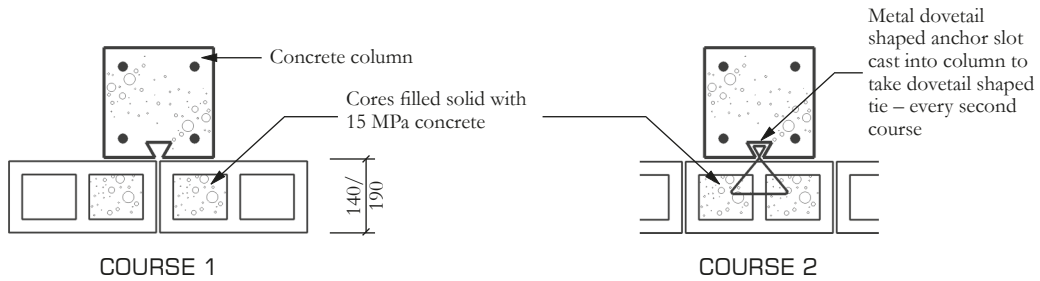

**WALL FIXED TO CONCRETE COLUMN PROVIDING LATERAL SUPPORT**

**H-CC-02**

See App E

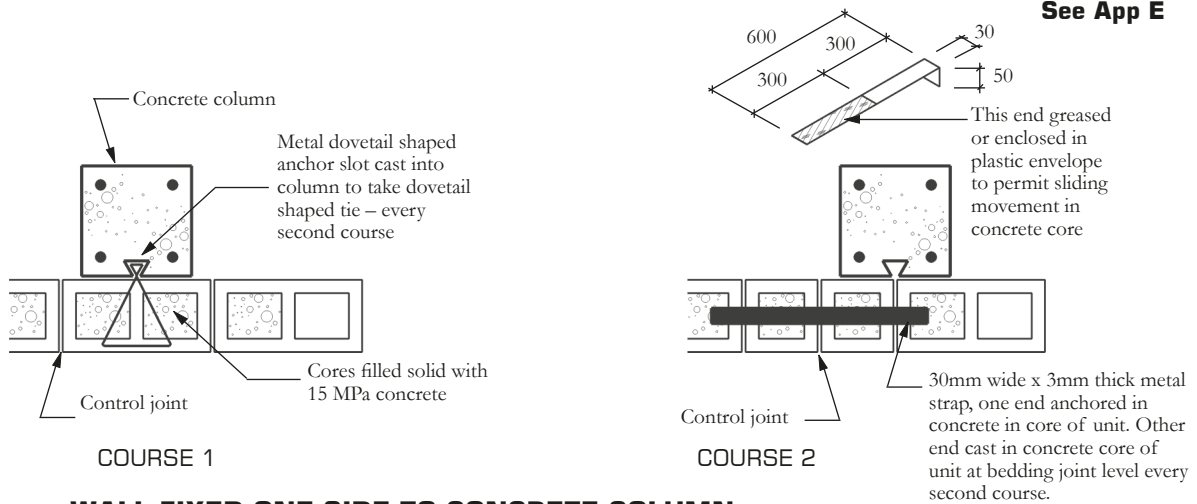

**WALL FIXED ONE SIDE TO CONCRETE COLUMN PROVIDING LATERAL SUPPORT, WITH CONTROL JOINT**

**H-CC-03**

See App C+E

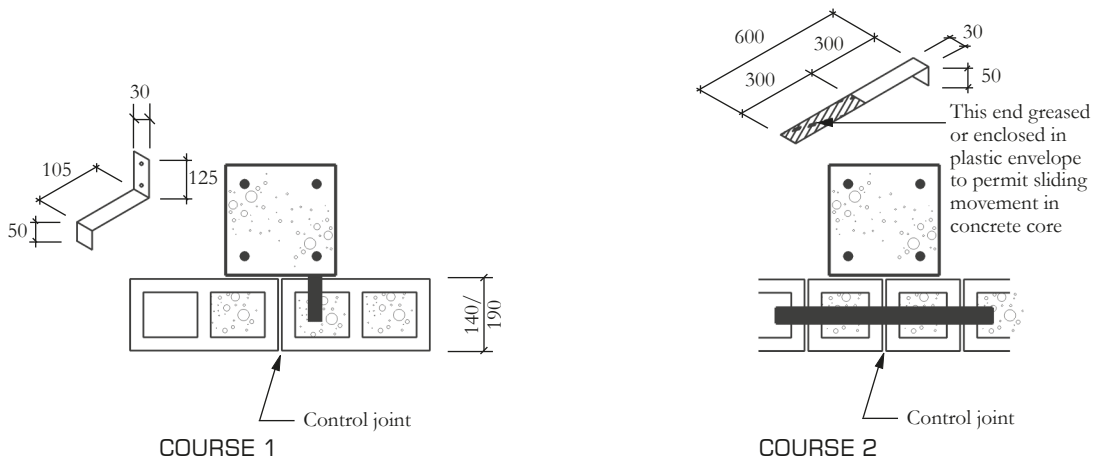

**WALL FIXED ONE SIDE TO CONCRETE COLUMN PROVIDING LATERAL SUPPORT, WITH CONTROL JOINT**

# CONCRETE COLUMN/WALL INTERSECTIONS

**H-CC-04**

See App C+E

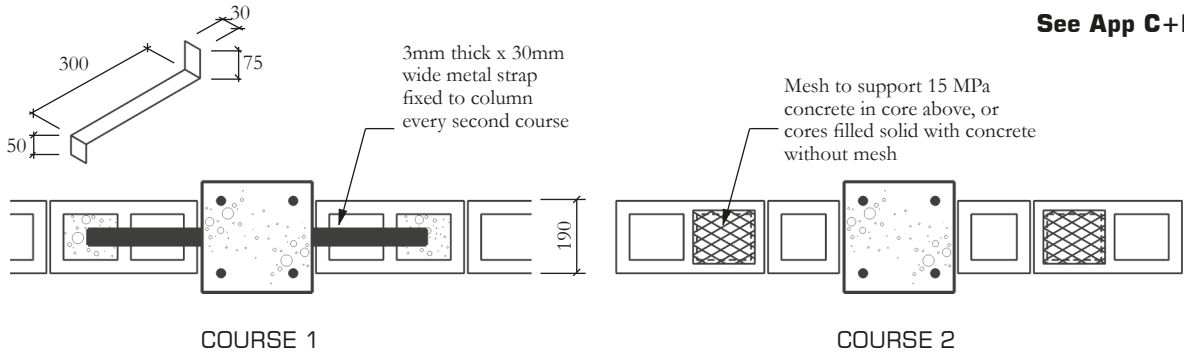

**190mm WALL RIGIDLY FIXED TO CONCRETE COLUMN - 400mm MODULE**

**H-CC-05**

See App C+E

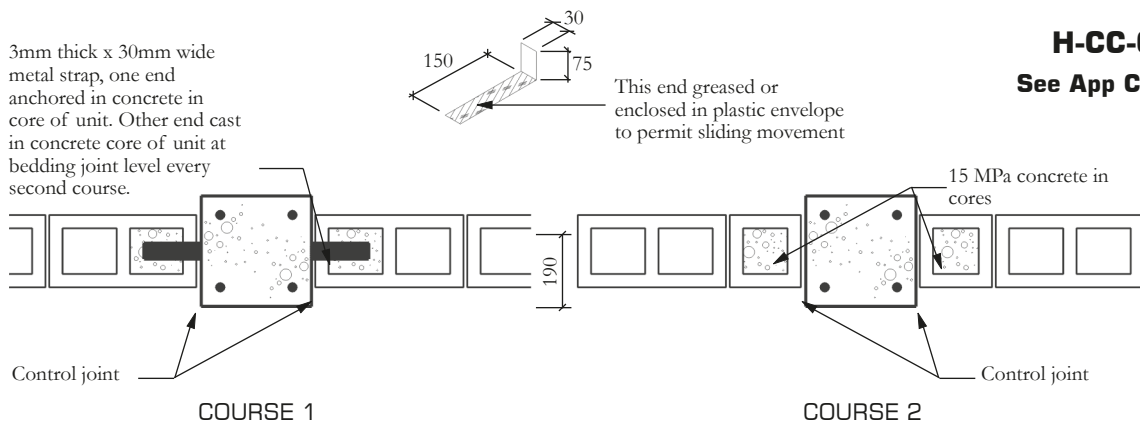

**WALL FIXING TO CONCRETE COLUMN PERMITTING LONGITUDINAL MOVEMENT - 400mm MODULE**

**H-CC-06**

See App C+E

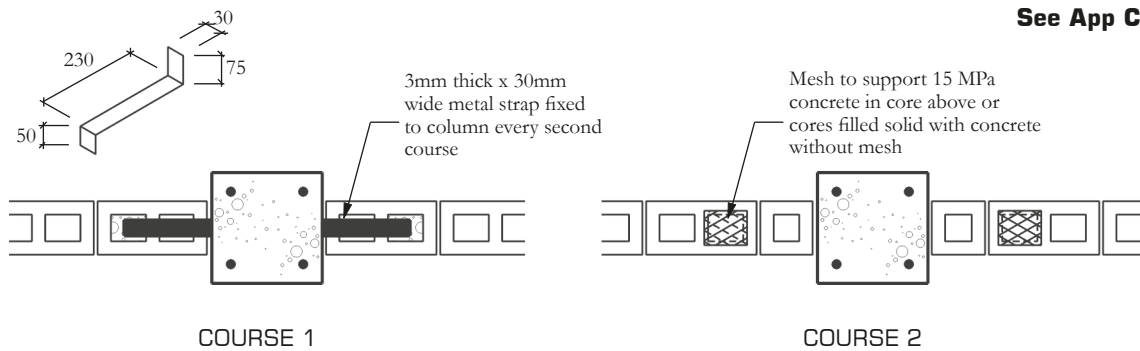

**140mm WALL RIGIDLY FIXED TO CONCRETE COLUMN 300mm MODULE (OR 400mm MODULE)**



## CONCRETE COLUMN/WALL INTERSECTIONS

**H-CC-07**  
See App C

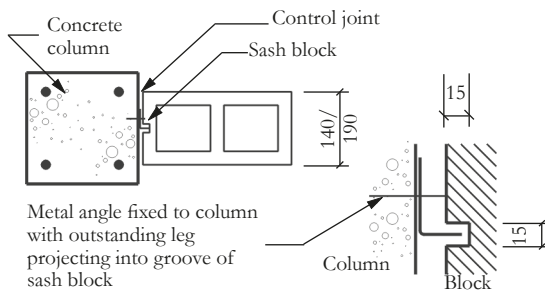

ANGLE IN SASH GROOVE

**WALL FIXED TO CONCRETE COLUMN  
PERMITTING LONGITUDINAL MOVEMENT**

**H-CC-08**  
See App C

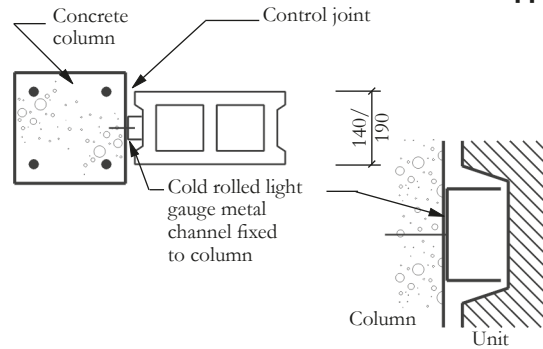

CHANNEL IN OPEN END OF UNIT

**WALL FIXED TO CONCRETE COLUMN  
PERMITTING LONGITUDINAL MOVEMENT**

**H-CC-09**  
See App C

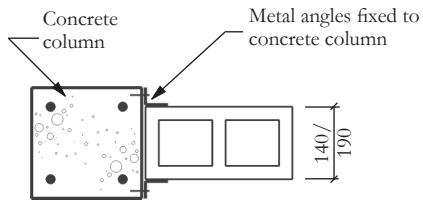

TWO ANGLES TO HOLD UNIT

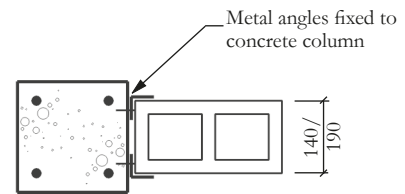

TWO ANGLES TO HOLD UNIT

**WALL FIXED TO CONCRETE COLUMN PERMITTING  
LONGITUDINAL MOVEMENT**

# CONCRETE COLUMNS WITH ROCKFACE SURROUNDS

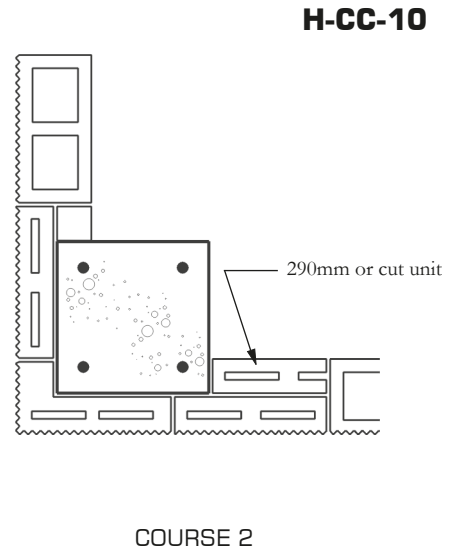
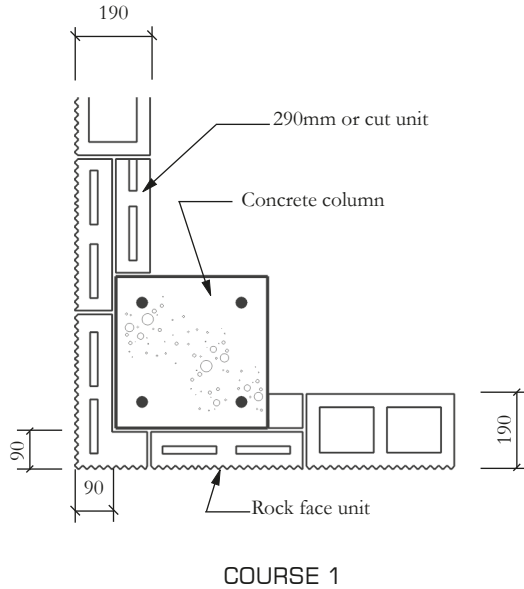

**CONCRETE COLUMN 400 x 400 WITH EXTERNAL FACE UNITS**

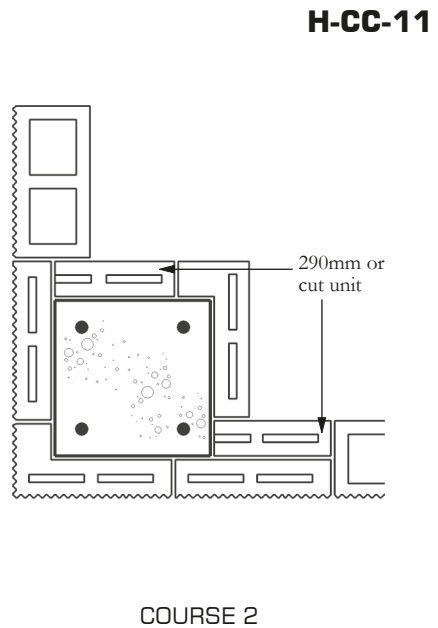
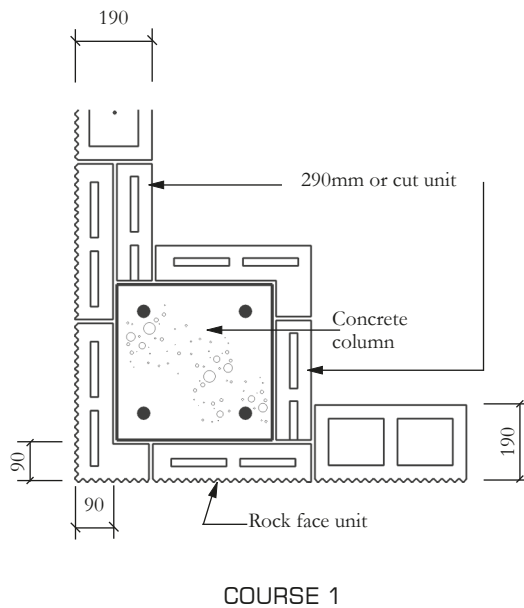

**CONCRETE COLUMN 400 x 400 BOXED IN WITH EXTERNAL FACE UNITS**

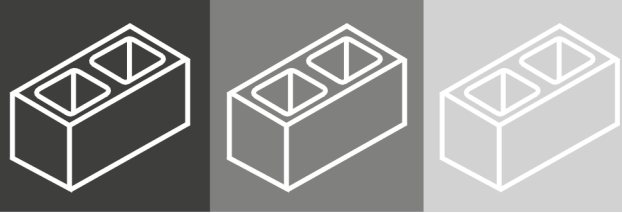

## CONCRETE COLUMNS WITH ROCKFACE SURROUNDS

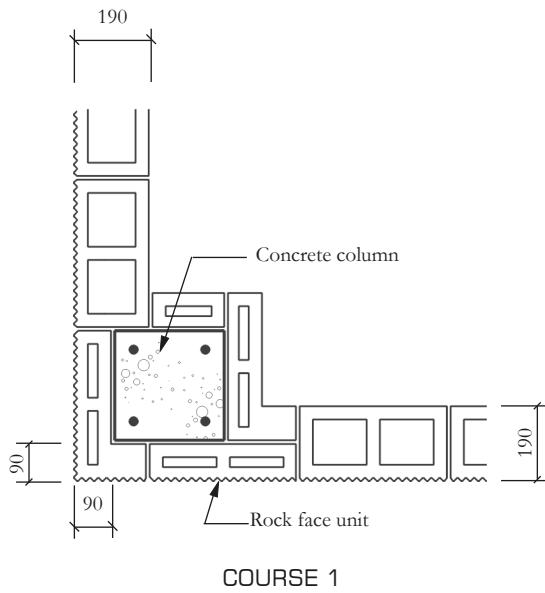

**H-CC-12**

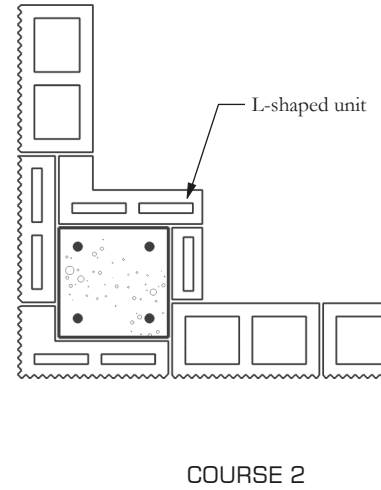

### CONCRETE COLUMN 300 x 300 BOXED IN - EXTERNAL FACE UNITS

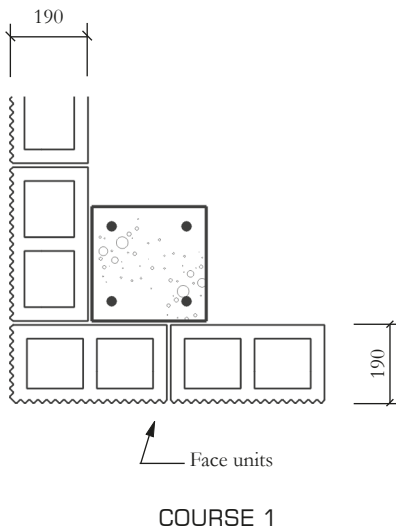

**H-CC-13**

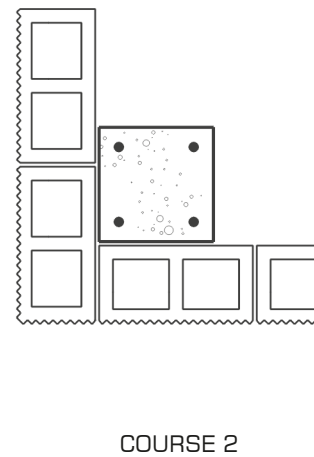

### CONCRETE COLUMN 300 x 300 - 190mm EXTERNAL FACE UNITS

# STEEL COLUMN/WALL INTERSECTIONS

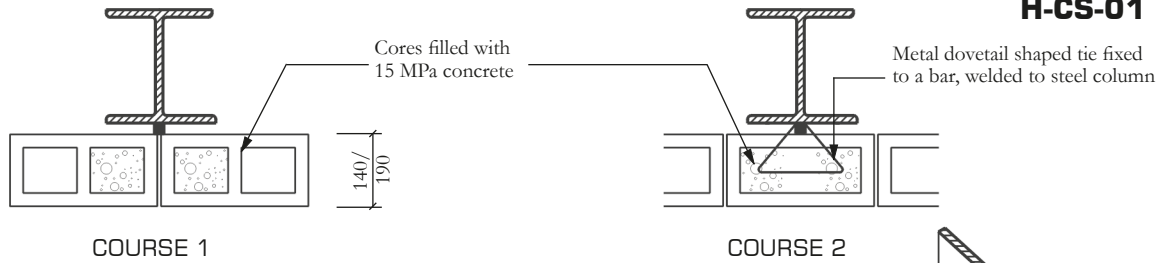

**H-CS-01**

## WALL FIXED TO COLUMN PROVIDING LATERAL SUPPORT

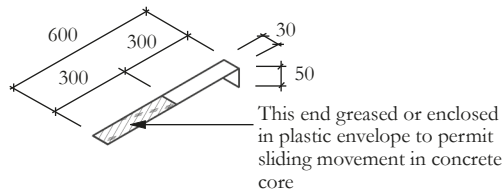

**H-CS-02**

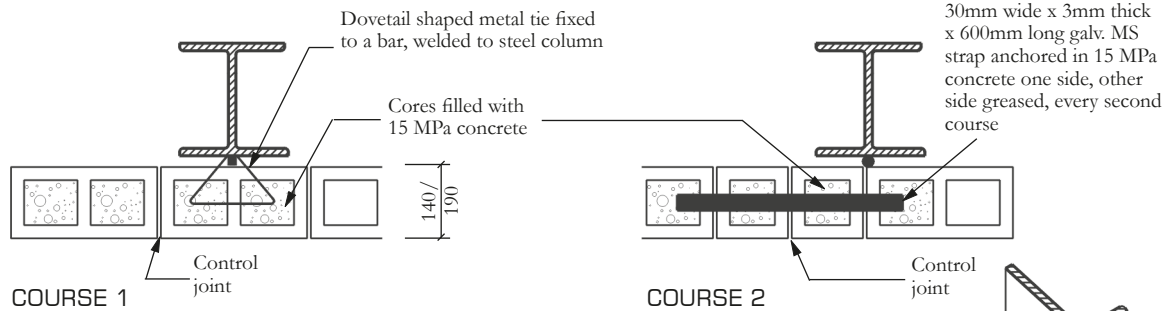

## WALL FIXED TO COLUMN PROVIDING LATERAL SUPPORT, WITH CONTROL JOINT

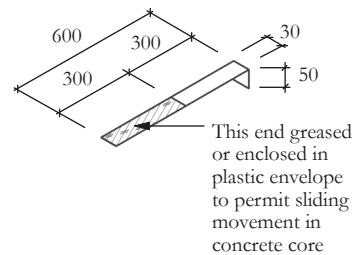

**H-CS-03**  
See App C

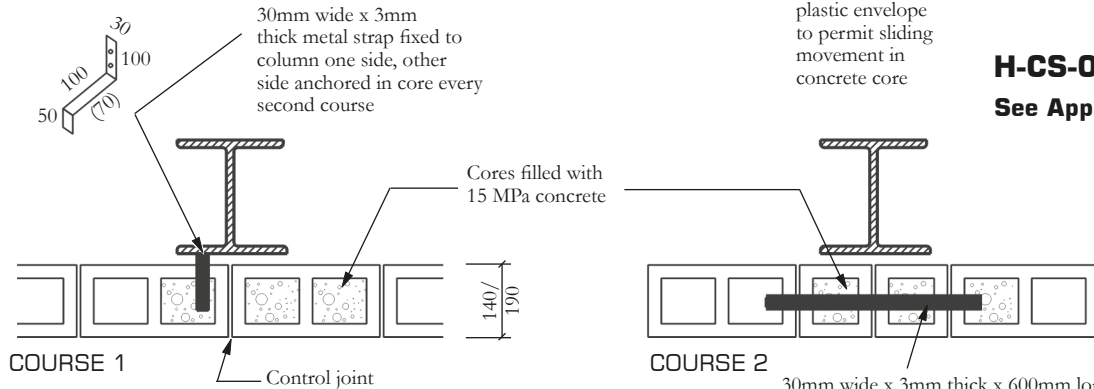

## ONE SIDE WALL RIGIDLY FIXED TO COLUMN OTHER SIDE FREE TO MOVE LONGITUDINALLY

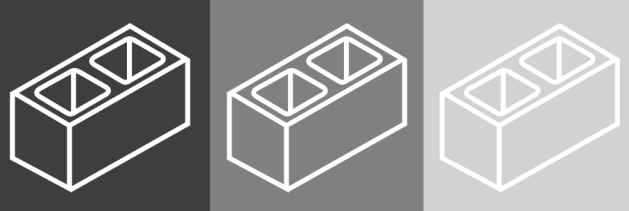

## STEEL COLUMN/WALL INTERSECTIONS

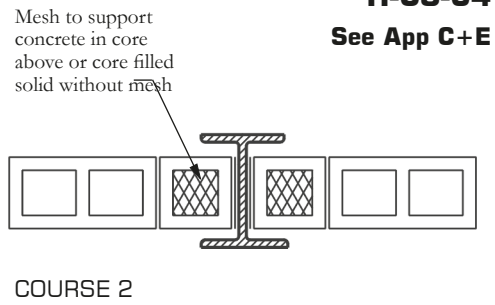
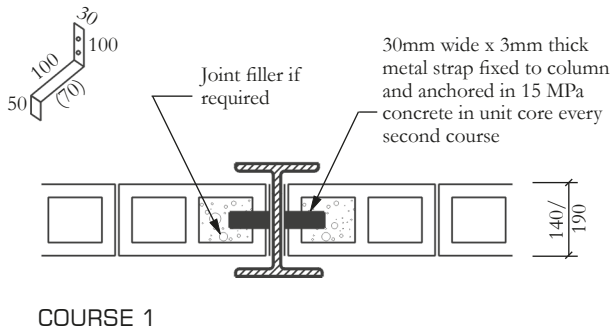

**H-CS-04**  
See App C+E

### WALL FIXED TO STEEL COLUMN

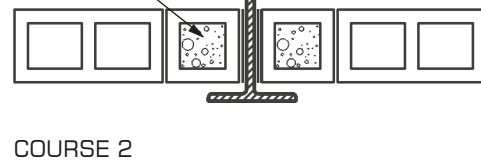
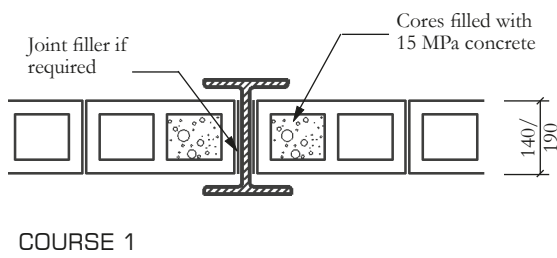

**H-CS-05**

### WALL BUTTING AGAINST STEEL COLUMN

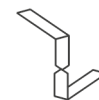
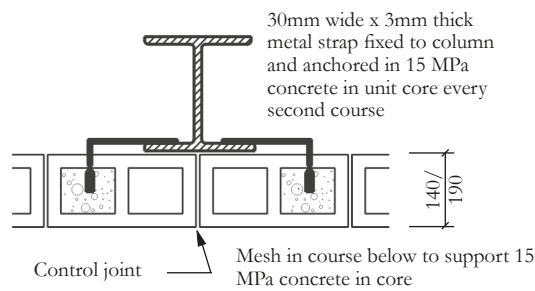

**H-CS-06**

### WALL FIXED TO STEEL COLUMN PROVIDING LATERAL SUPPORT WITH CONTROL JOINT

# STEEL COLUMN/WALL INTERSECTIONS

**H-CS-07**

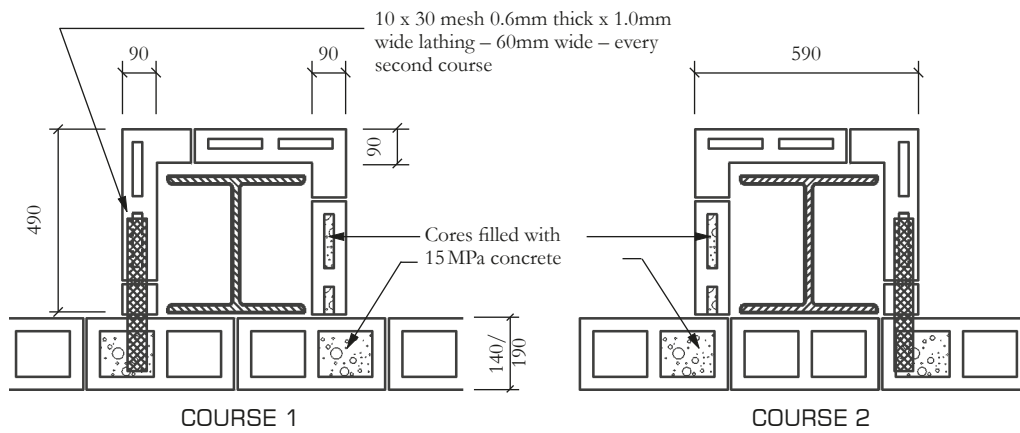

**STEEL COLUMN BOXED IN**

**H-CS-08**

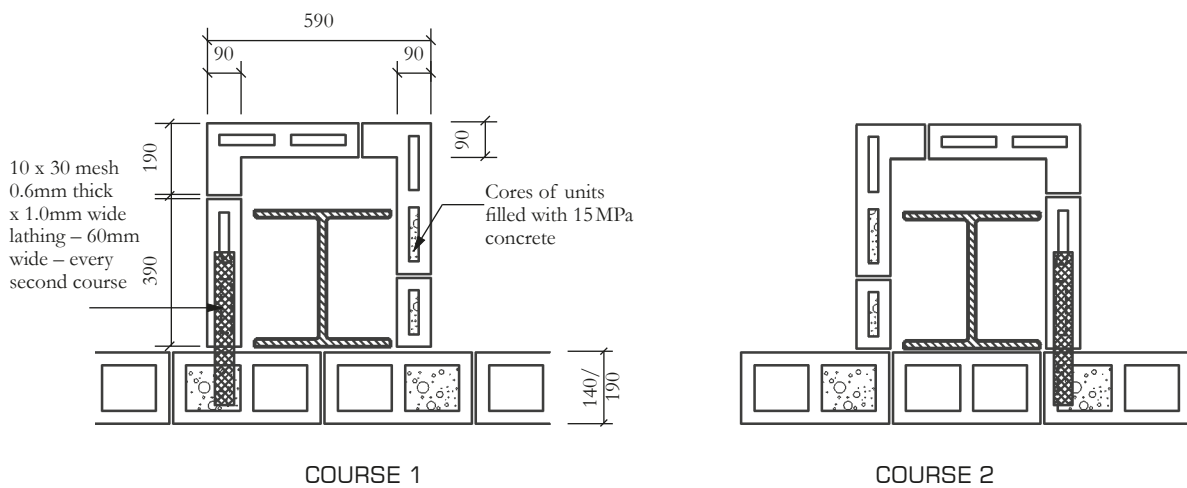

**STEEL COLUMN BOXED IN**

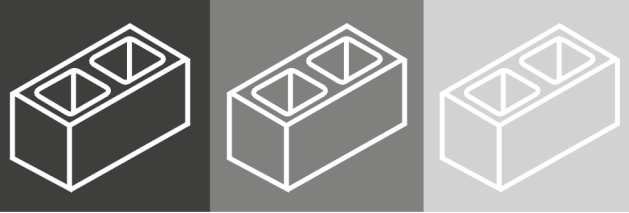

## STEEL COLUMN/WALL INTERSECTIONS – ROCKFACE FINISH

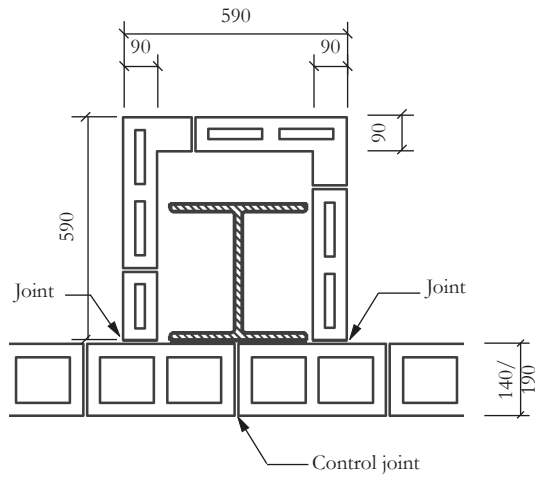

COURSE 1

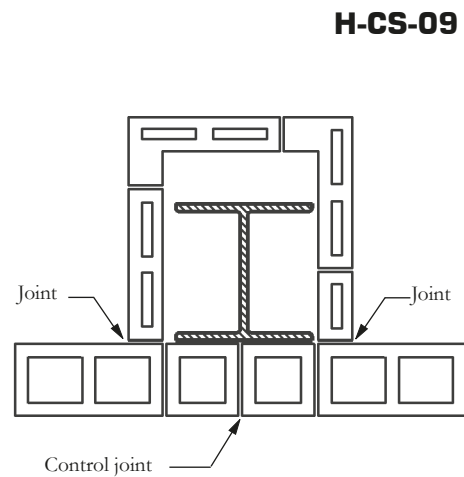

COURSE 2

**H-CS-09**

### STEEL COLUMN BOXED IN WITH CONTROL JOINTS

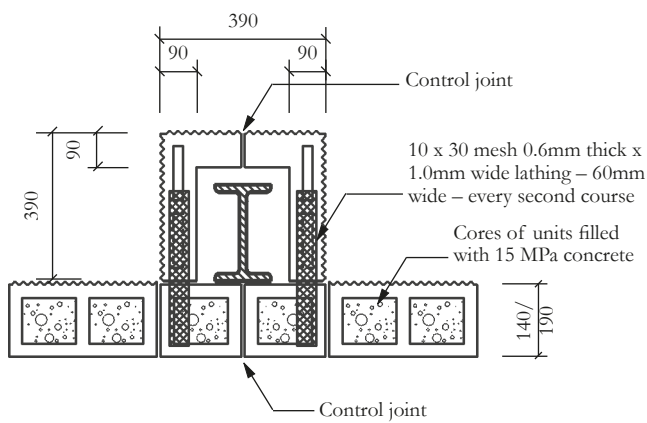

COURSE 1

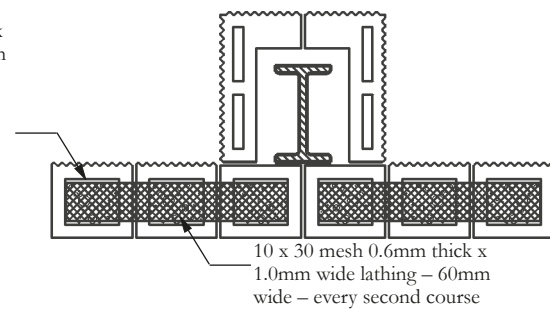

COURSE 2

**H-CS-10**

### STEEL COLUMN BOXED IN WITH ROCK FACE UNITS WITH CONTROL JOINT

# STEEL COLUMN WITH ROCKFACE UNITS SURROUND

**H-CS-11**

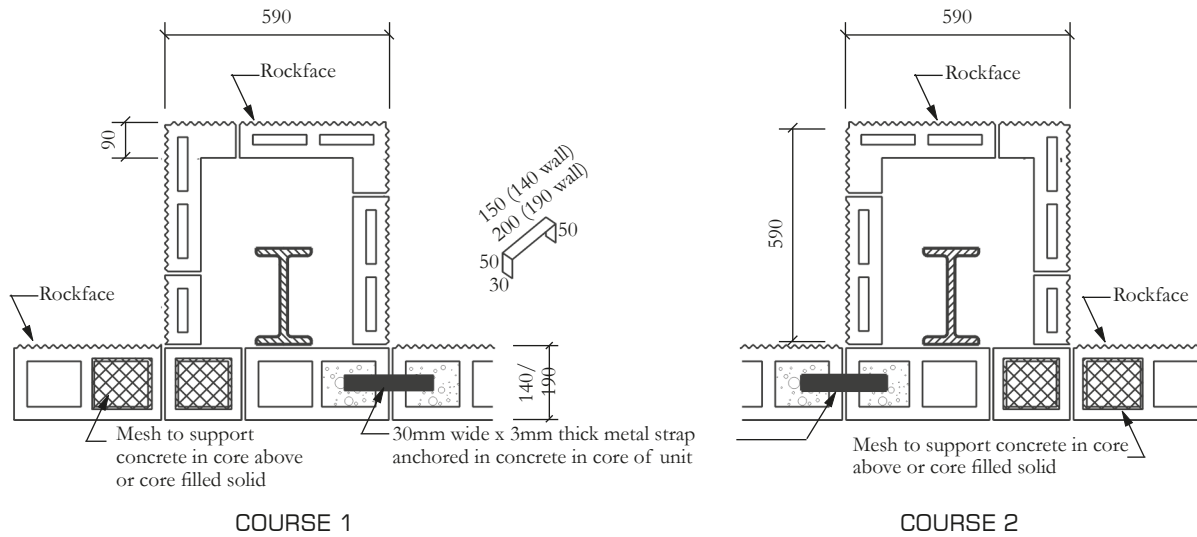

## STEEL COLUMN BOXED IN WITH ROCK FACE UNITS

**H-CS-12**

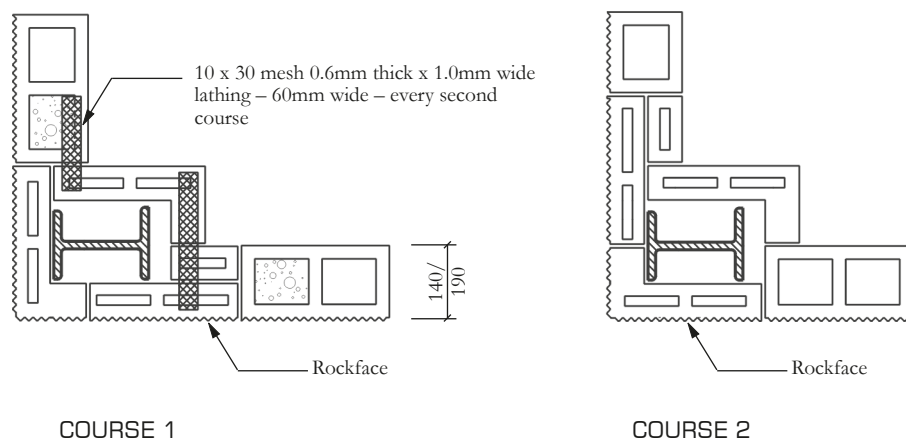

## CORNER STEEL COLUMN BOXED IN WITH ROCK FACE UNITS

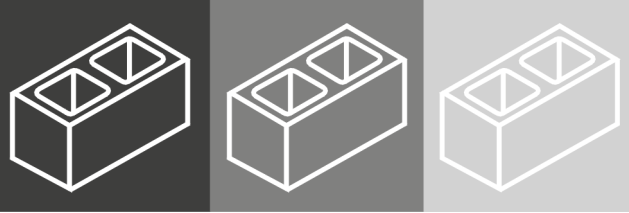

## DETAILS OF BEAM BEARING AND EMBEDMENT OF ANCHOR BOLTS

### H-BW-01

See App C

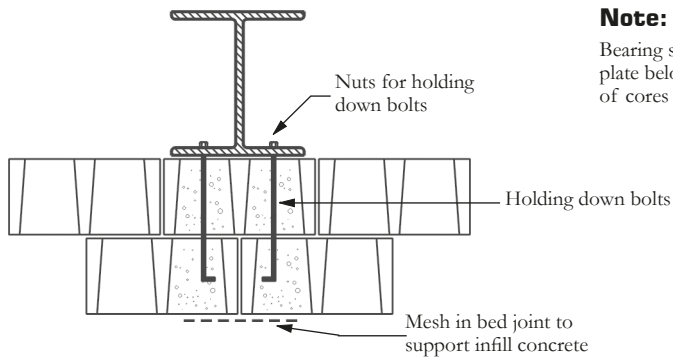

SECTIONAL ELEVATION

**Note:**

Bearing stresses under steel beam will determine if steel bearing plate below beam required and depth and extent of concrete infill of cores of blocks

### WALL SUPPORTING OF STEEL BEAM

### H-BW-02

See App C

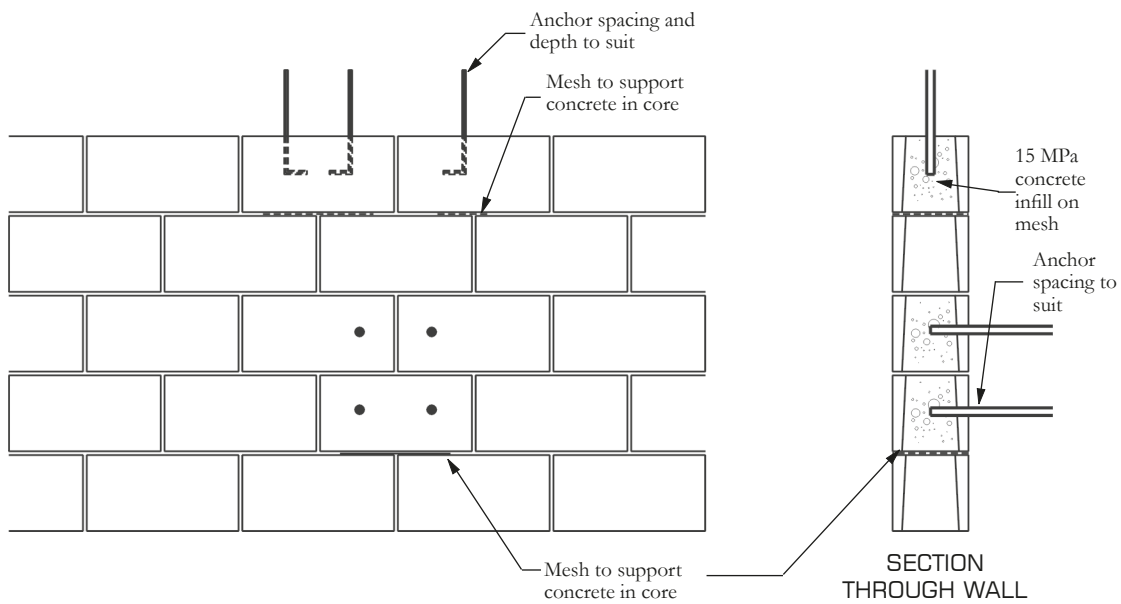

SECTION THROUGH WALL

### ANCHOR BOLTS TO SUPPORT VERTICAL OR HORIZONTAL LOADS

# CONTROL JOINTS IN WALLS

## H-CJ-01

See H-CJ-NB (1 TO 4)

30mm wide x 3mm thick metal strap placed in bedding joint. Cores of units filled with 15MPa concrete, one end fixed, other end free to slide every second course

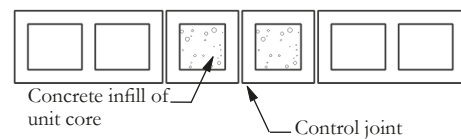
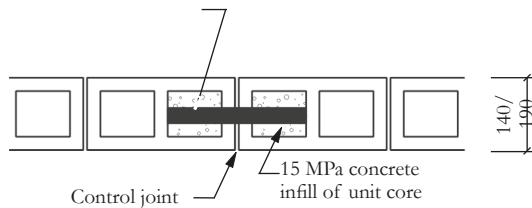
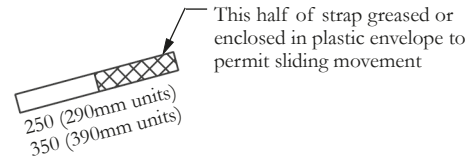

COURSE 1

COURSE 2

### BUTT JOINT WITH STRAP TO GIVE LATERAL STABILITY

## H-CJ-02

See H-CJ-NB (1 TO 4)

15 MPa concrete infill in cores on either side of control joint

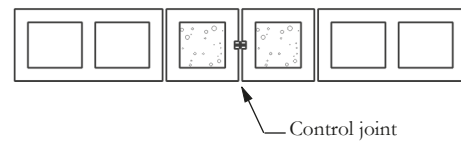
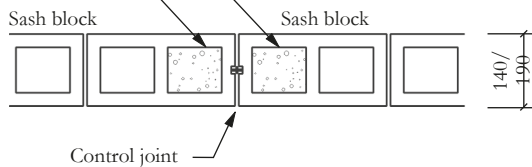
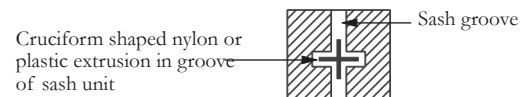

COURSE 1

COURSE 2

### BUTT JOINT WITH CRUCIFORM STRIP IN SASH UNIT GROOVES - NO LATERAL STABILITY

## H-CJ-03

See H-CJ-NB (1 TO 4)

15 MPa concrete infill in cores on either side of control joint



COURSE 1

COURSE 2

### BUTT JOINT - NO LATERAL STABILITY



**CONTROL JOINTS IN WALLS**

**H-CJ-04**

See H-CJ-NB (1 TO 4)

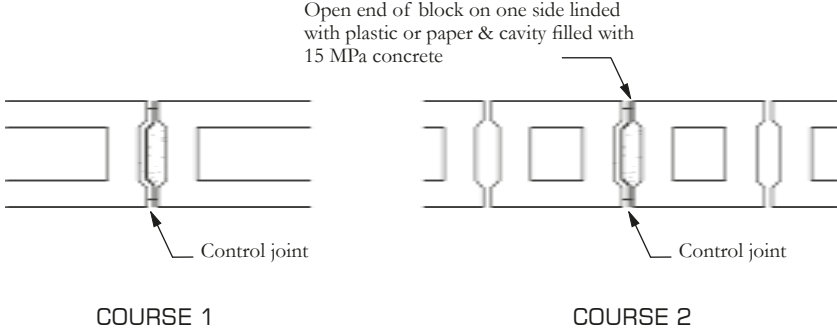

**BUTT JOINT WITH OPEN ENDS FILLED TO GIVE LATERAL STABILITY**

**H-CJ-05**

H-CJ-NB (1 TO 4)

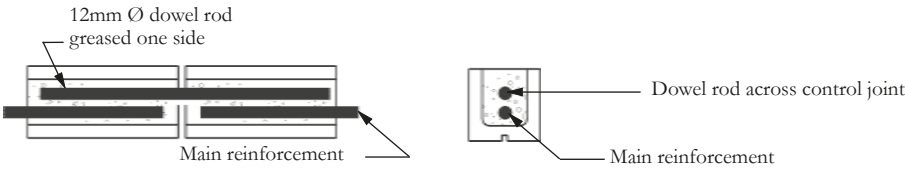

**BUTT JOINT IN U OR BOND BEAMS WITH ROD TO GIVE LATERAL STABILITY**

# CONTROL JOINTS IN WALLS

**H-CJ-NB1**

**Note:**

- Control joints may be filled with a joint filler such as fibre board, polystyrene or polyurethane strips, sponges, tubes or rods and sealed with sealants such as silicones, polyurethanes, polysulphides, bitumen, acrylic or polyisobutylenes. Refer to manufacturers specification.

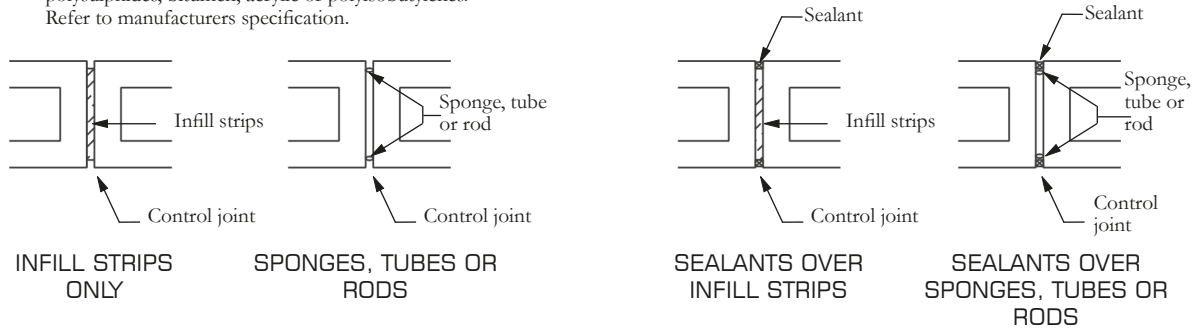

\* **INTERNAL WALL**

\* **EXTERNAL WALL**

- If plastered then V-joint is to be cut into plaster over line of control joint.

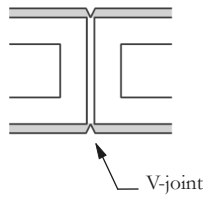

- Control joint may be covered by a cover plate.

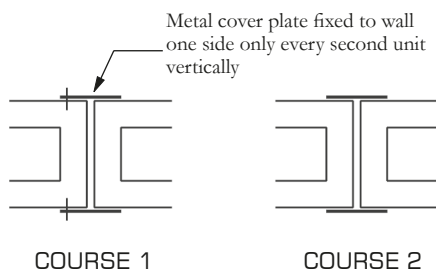

**FLAT COVER PLATE FIXED ONE SIDE**

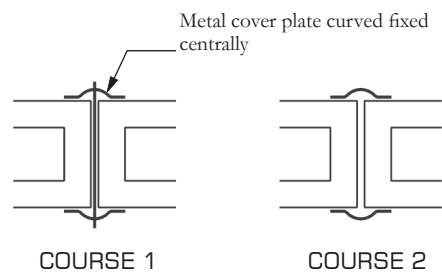

**CURVED COVER PLATE FIXED CENTRALLY**

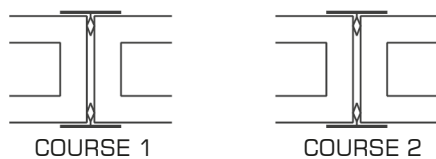

**SPRING CLIP COVERS**

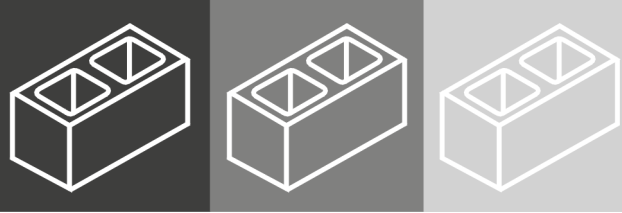

## CONTROL JOINTS IN WALLS – LOCATIONS

### H-CJ-NB2

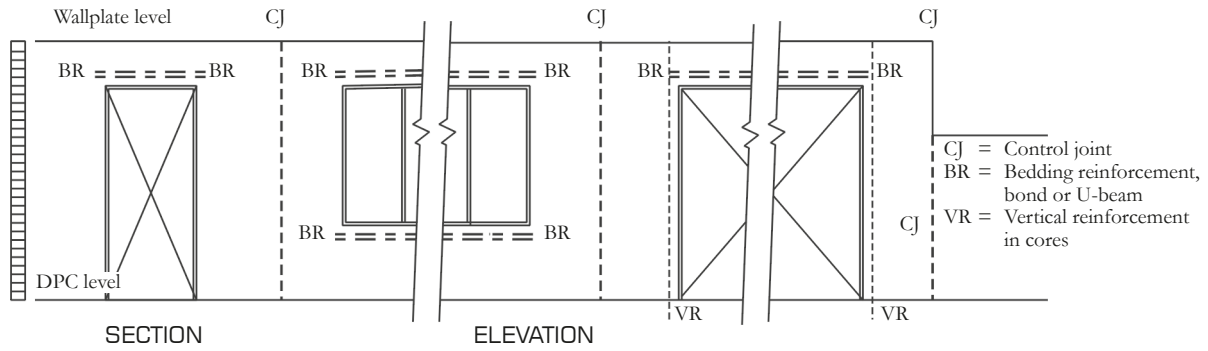

**ELEVATION OF WALL SHOWING CONTROL JOINT POSITIONS BETWEEN OPENINGS, HORIZONTAL & VERTICAL REINFORCEMENT**

### H-CJ-NB3

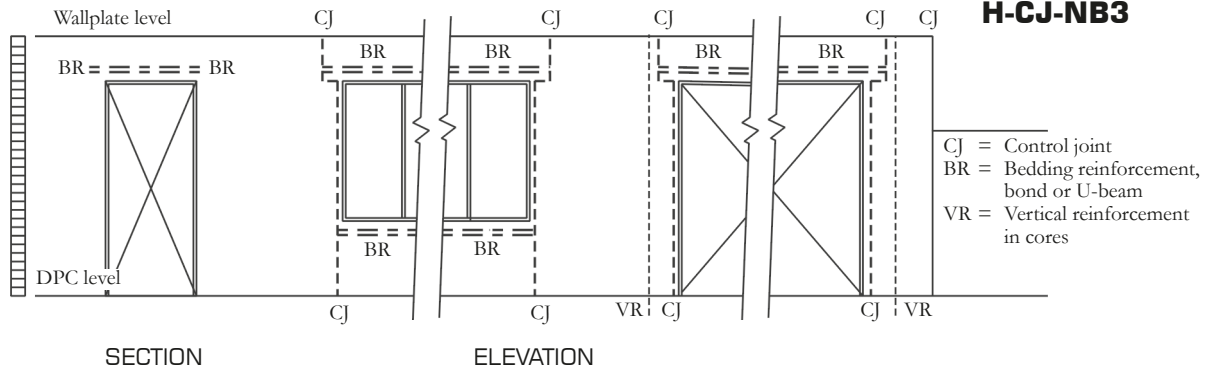

**ELEVATION OF WALL SHOWING CONTROL JOINT POSITIONS AT EDGE OF OPENINGS, HORIZONTAL & VERTICAL REINFORCEMENT**

### H-CJ-NB4

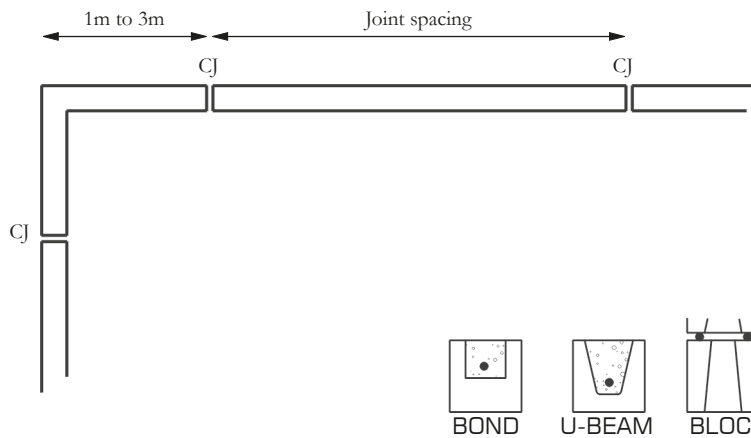

**Note:**

Control joint spacing not to exceed recommended maximum, i.e. for unreinforced walls-6m, or twice the height of the wall. For reinforced walls-18m. Every course reinforced.

BEDDING REINFORCEMENT

For detailed information refer to CMA Masonry Manual and SANS 10145 Concrete Masonry Construction

**PLAN OF WALL SHOWING CONTROL JOINT POSITIONS**

## DETAILS OF TYPES OF REINFORCEMENT AND FIXING

**H-RE-01**

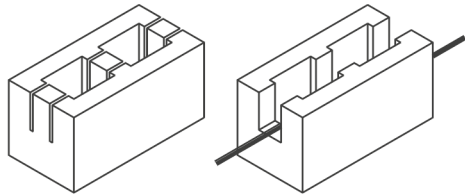

REINFORCEMENT  
BOTTOM ONLY

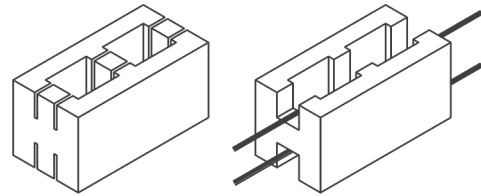

REINFORCEMENT  
TOP ONLY

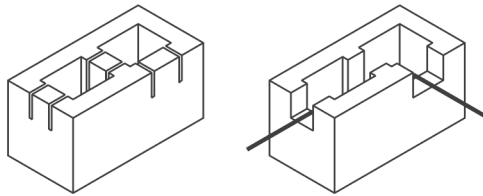

REINFORCED  
AROUND CORNER

### CUT HOLLOW UNITS TO ACCOMMODATE REINFORCEMENT

**H-RE-02**

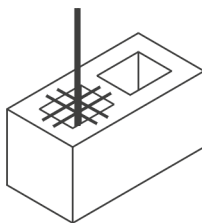

SINGLE VERTICAL  
BAR

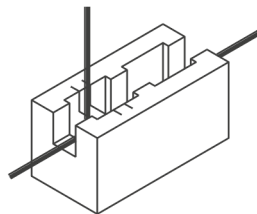

VERTICAL AND HORIZONTAL BARS

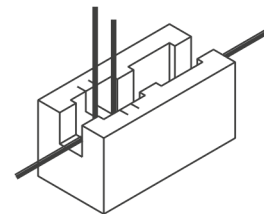

### VARIOUS WIRE POSITIONERS TO HOLD REINFORCEMENT IN POSITION BEFORE CONCRETING

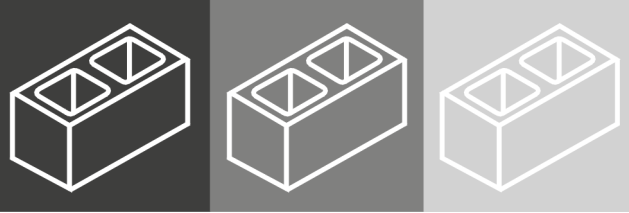

## DETAILS OF TYPES OF REINFORCEMENT AND FIXING

**H-RE-03**

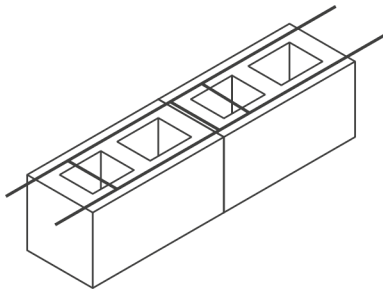

LADDER PATTERN

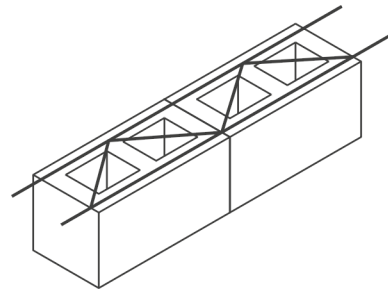

TRUSS PATTERN

### VARIOUS TYPES BEDDING JOINT REINFORCEMENT

**H-RE-04**

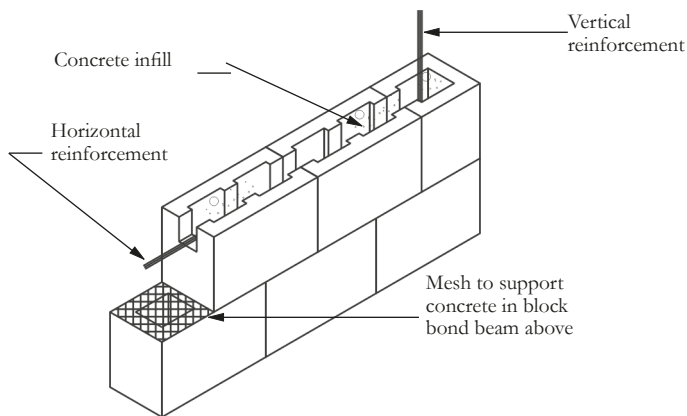

**SINGLE BLOCK BEAM**

**H-RE-05**

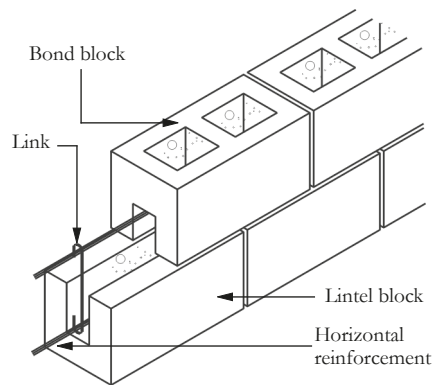

**DOUBLE BLOCK BEAM**

## REINFORCEMENT DETAILS – BEAMS

**H-RE-06**

Reinforcing bars alternate sides if required to engineers requirements

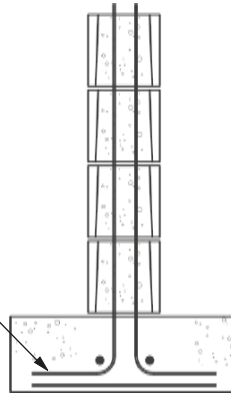

**CANTILEVER WALL**

**H-RE-07**  
See H-RE-NB

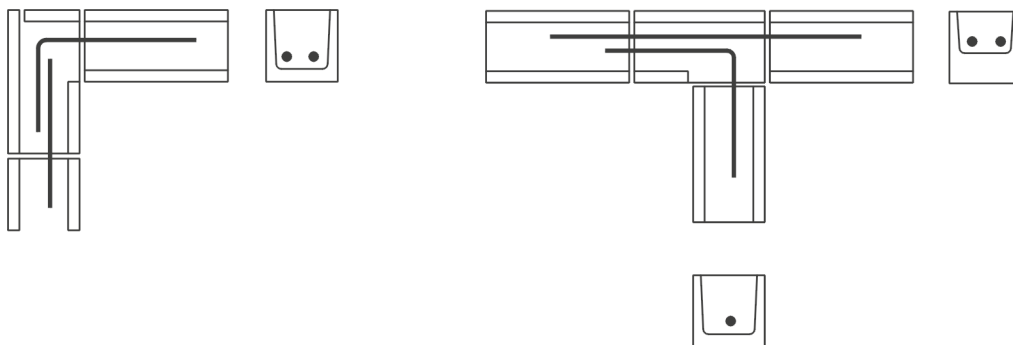

**SINGLE BAR IN BEAM**

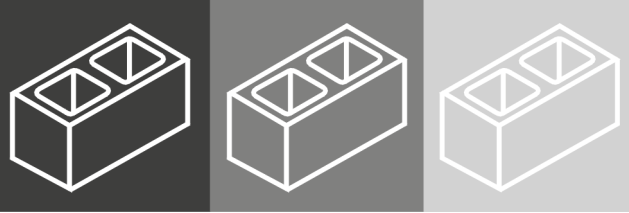

## REINFORCEMENT DETAILS – BEAMS

**H-RE-08**  
See H-RE-NB

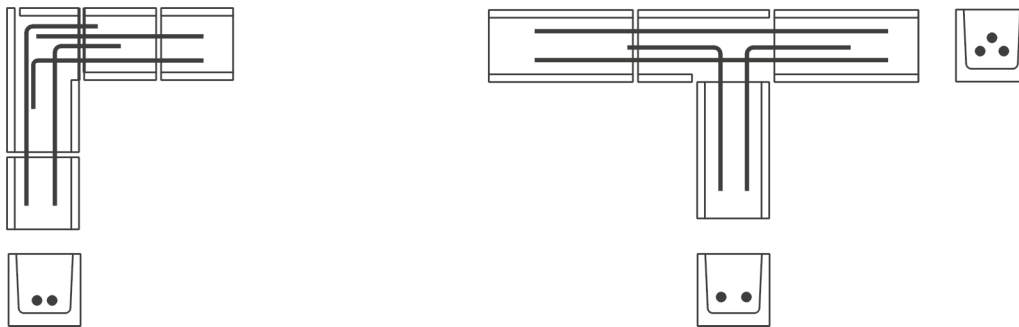

**TWO BARS IN BEAM**

**H-RE-09**  
See H-RE-NB

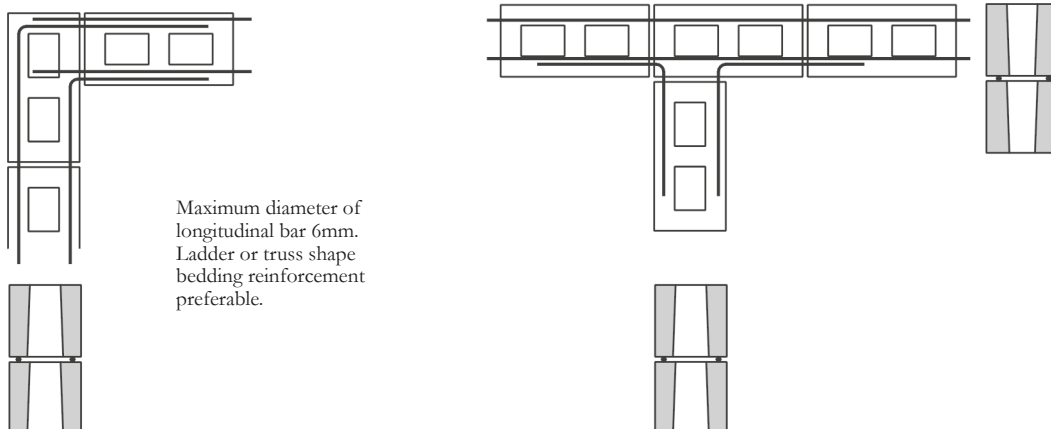

**REINFORCEMENT AROUND CORNERS IN BEDDING JOINT**

# REINFORCED MASONRY – FOUNDATIONS

**H-RE-10**

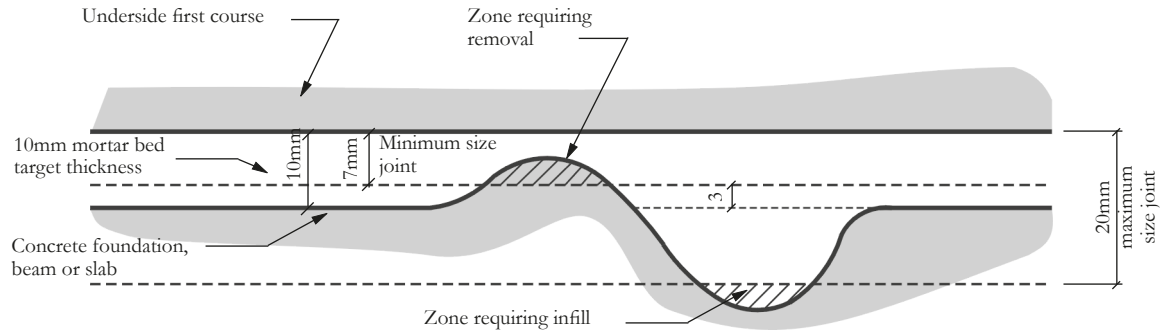

## TOLERANCES OF SURFACES OF FOUNDATIONS, BEAMS OR SLABS SUPPORTING STRUCTURAL MASONRY

**H-RE-11**

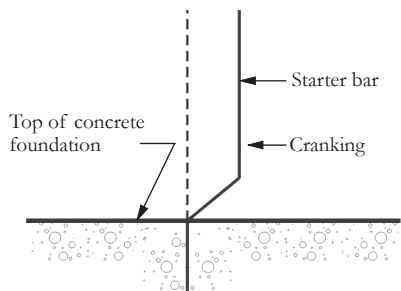

**CRANKING NOT PERMITTED**

**H-RE-12**

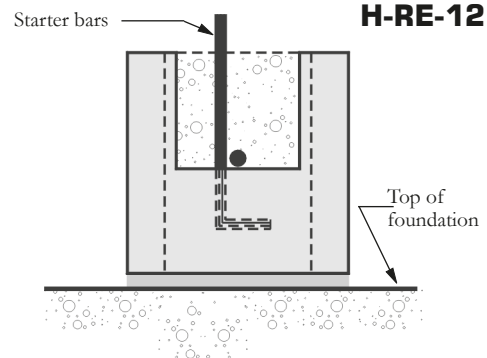

**STARTER BARS IN BOND BEAM**

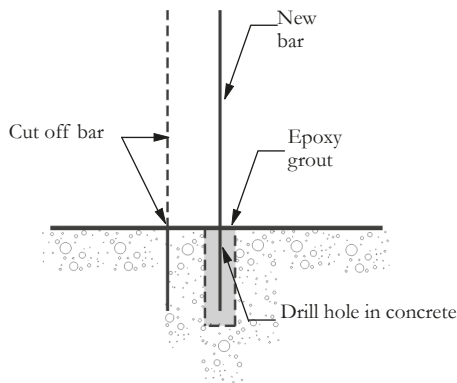

**REMEDIAL WORK 'OUT OF POSITION' STARTER BARS**

**H-RE-13**

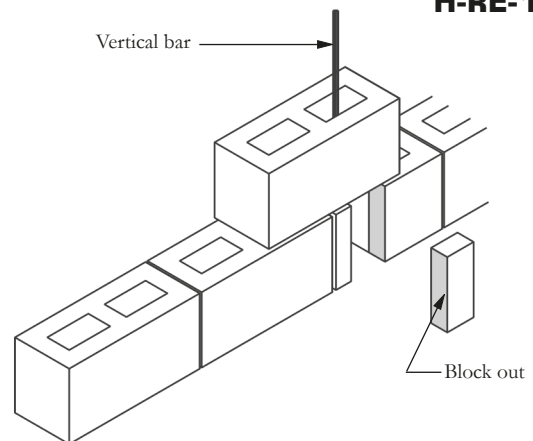

**FIRST COURSE INSPECTION & CLEAN OUT UNIT**

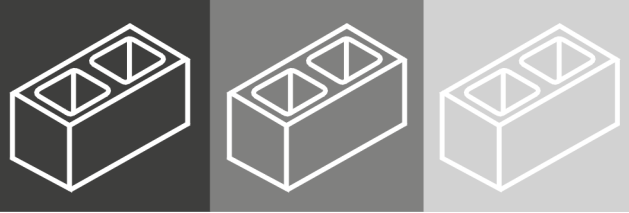

## REINFORCEMENT DETAILS – U-BEAM/LINTEL AND BOND BLOCKS

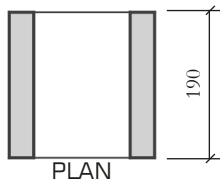
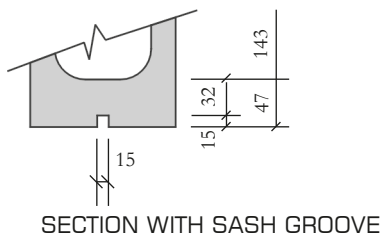
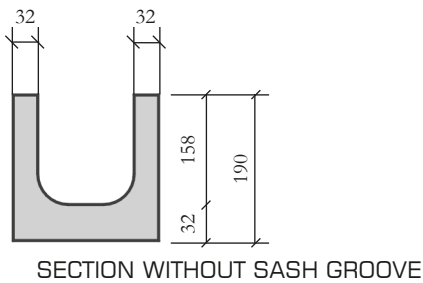

**Note:**

Usually 190mm long, in fair face only with sash groove in soffit

**U-BEAM OR LINTEL BLOCK**

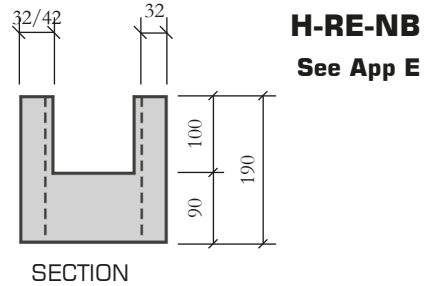

**H-RE-NB**

See App E

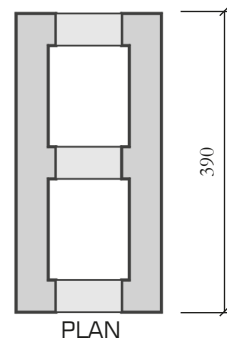

**Note:**

Bond blocks can be cut or manufactured. Typical dimensions as shown.

Outer shell thickness:

- Fairface – 32mm
- Rockface – 42mm

Bond blocks can be made with same colour and texture as standard blocks.

**BOND BLOCK**

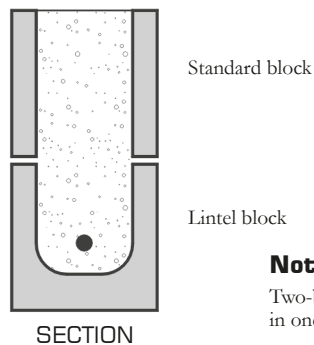

**TWO BLOCK BEAM USING LINTEL BLOCK**

**Note:**

Two-block beams to be cast in one operation

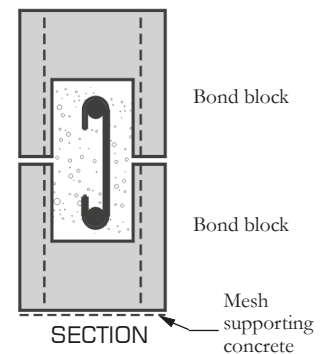

**TWO BLOCK BEAM USING BOND BLOCKS**

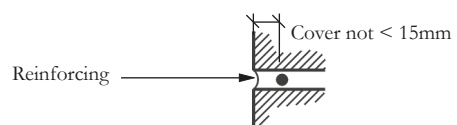

**REINFORCEMENT COVER IN BEDDING JOINT**

## DETAILS OF AIRCONDITIONING UNIT INSTALLATION

### H-AC-01

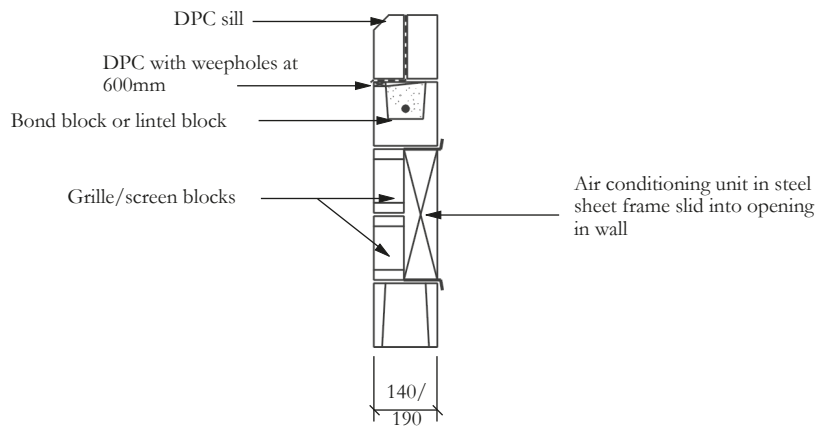

### AIR CONDITIONING UNIT INSTALLATION

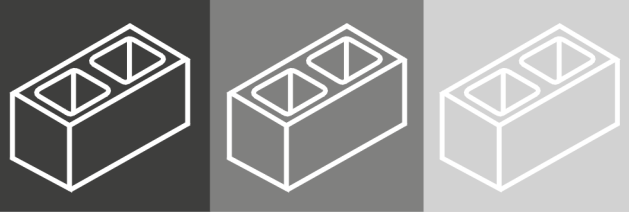

**LOCATION OF SERVICES IN/ON WALLS**

**H-SV-01**  
See H-SV-NB

**H-SV-02**  
See H-SV-NB

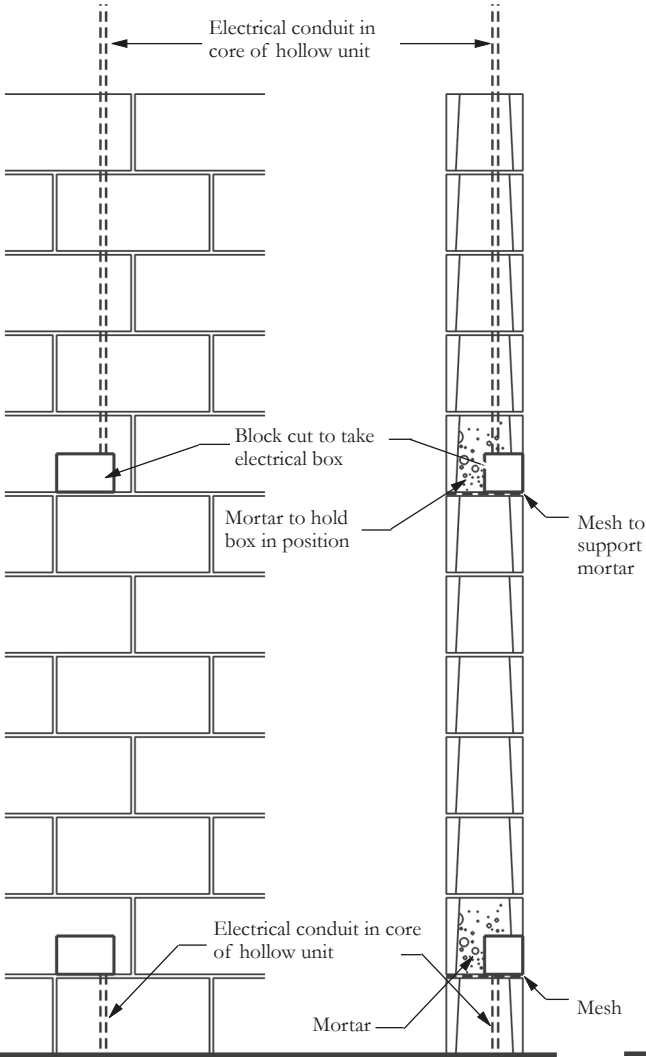

ELEVATION

SECTION

**ELECTRICAL CONDUITS PLACED IN CORES OF HOLLOW UNITS**

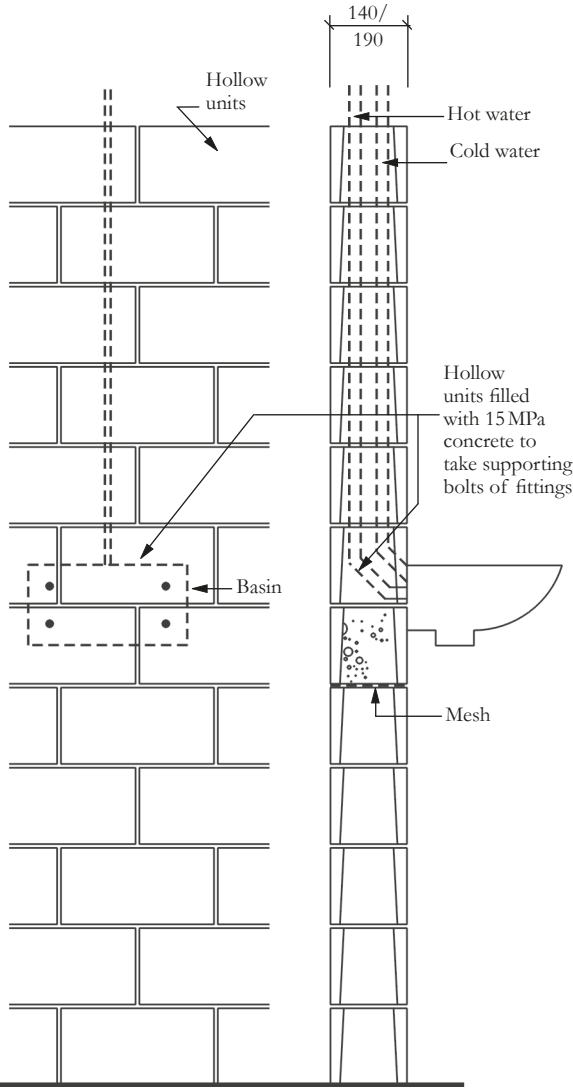

ELEVATION

SECTION

**WATER PIPES PLACED IN CORES OF HOLLOW UNITS**

# LOCATION OF SERVICES IN/ON WALLS

**H-SV-03**  
See H-SV-NB

**H-SV-04**  
See H-SV-NB

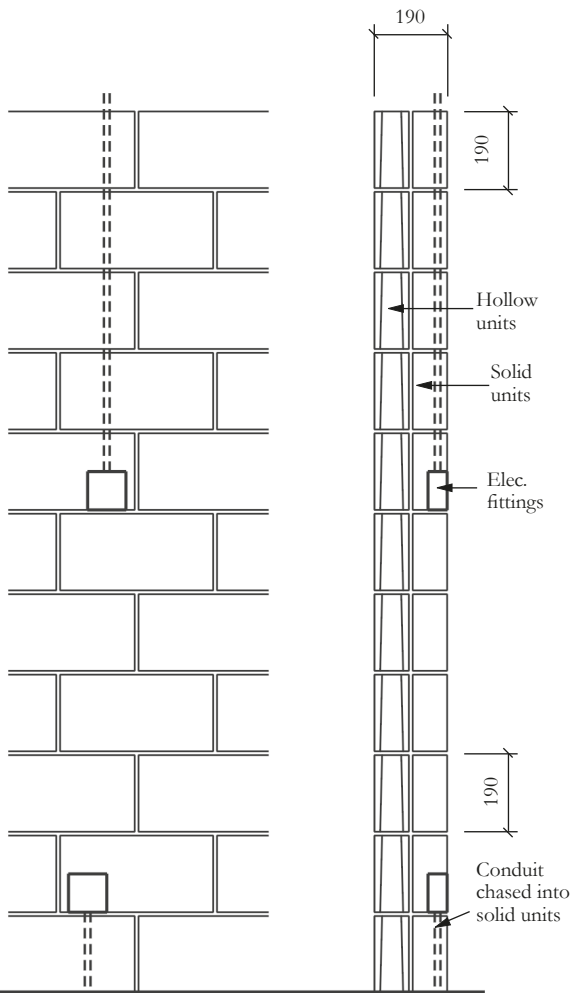

ELEVATION

SECTION

**ELECTRICAL CONDUITS CHASED INTO SOLID UNITS**

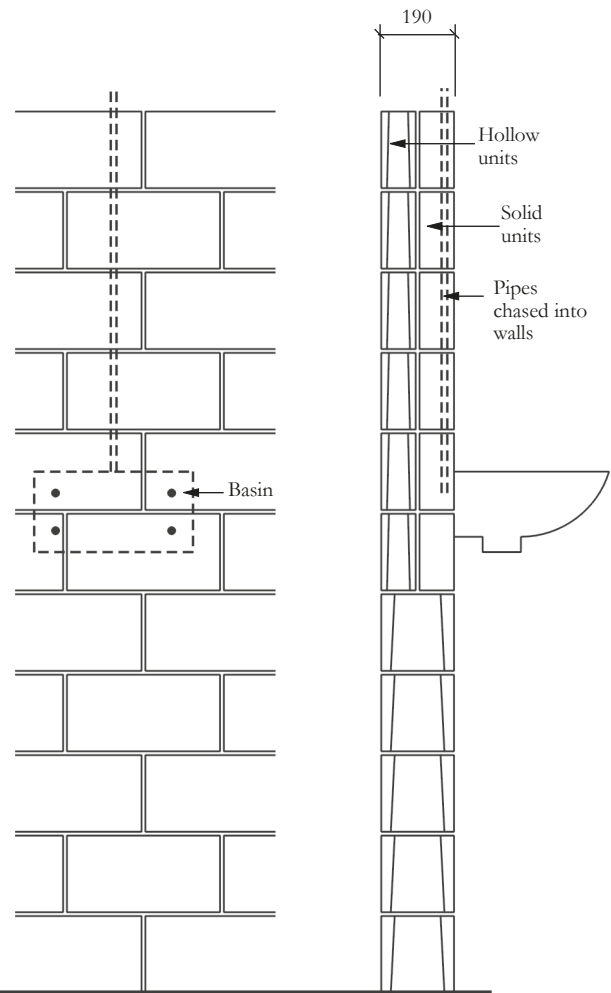

ELEVATION

SECTION

**WATER PIPES CHASED INTO SOLID UNITS**

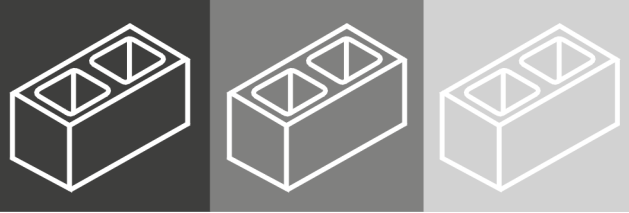

## LOCATION OF SERVICES IN/ON WALLS

### H-SV-05

See H-SV-NB

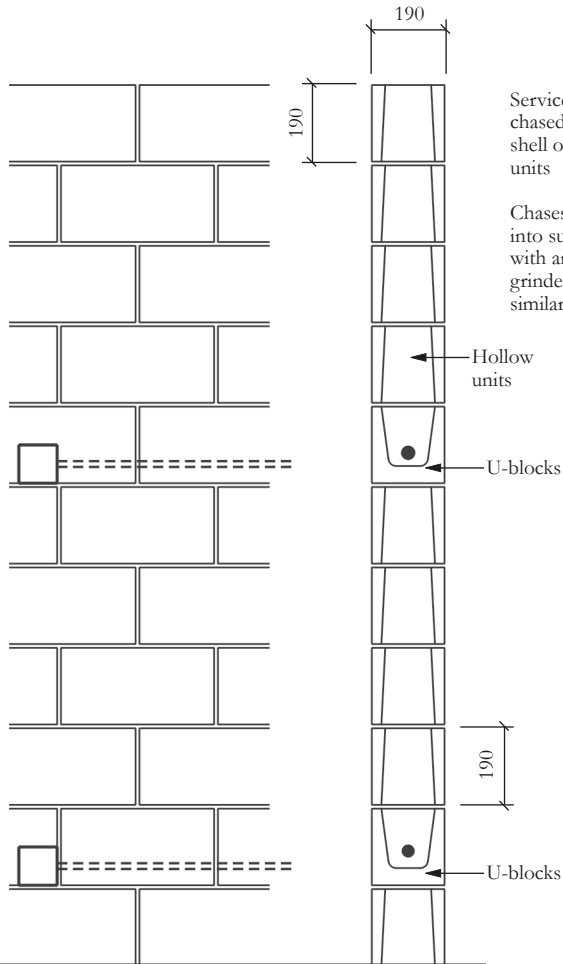

ELEVATION

SECTION

### HORIZONTAL SERVICES LOCATED IN U-BLOCKS

### H-SV-06

See H-SV-NB

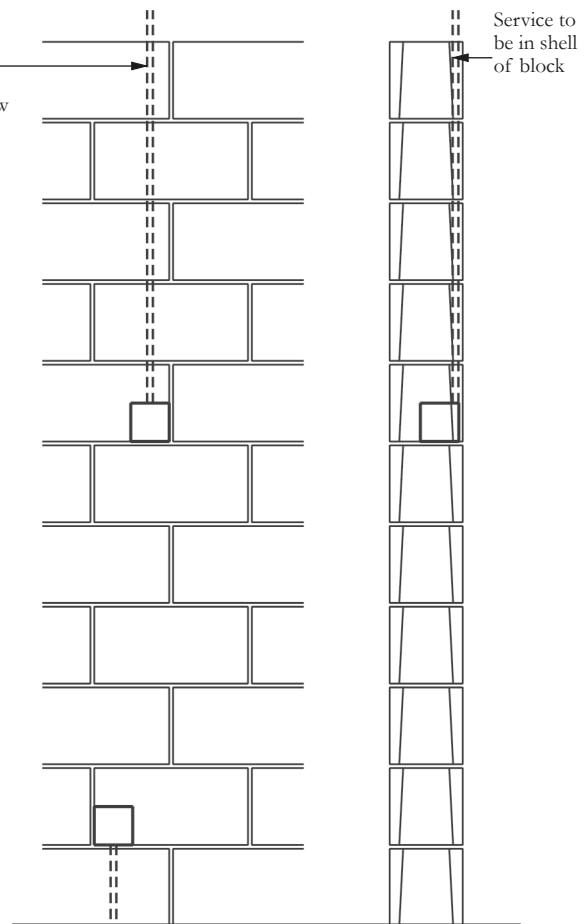

ELEVATION

SECTION

### VERTICAL SERVICES CHASED INTO SHELLS OF HOLLOW UNITS

**Note:**

If chases through shell of unit then core to be filled with 15 MPa concrete

### H-SV-NB

**Note:**

1. 'Sleeves, chases and holes should, as far as possible, be provided during the erection of the masonry, or purpose-made chased units should be built in position agreed by the designer'. Refer to SANS 10164-1
2. Vertical chases in solid units should not exceed one third of the wall/leaf thickness and horizontal chases should not exceed one sixth of the wall/leaf thickness. (See Note 4)
3. Walls constructed of hollow units should not be chased at all and services should be located in the unit cavities. Where chasing in these units is unavoidable it should be no deeper than 15mm or the core of the unit shall be filled with 15 MPa concrete.
4. Horizontal chasing should be avoided where possible. Ensure that chases do not impare strength, stability and fire resistance properties of the walling below the minimum permitted.

## APPENDICES

APPENDIX A	DEFINITIONS	65
APPENDIX B	REFERENCES	66
APPENDIX C	ANCHORS-WALLS	68
APPENDIX D	ROOF FIXING	69
APPENDIX E	TIES, STRAPS AND BEDDING REINFORCEMENT	70
APPENDIX F	DETAILING PRACTICE FOR REINFORCED MASONRY	71
APPENDIX G	V-JOINT IN PLASTERS AND MORTARS	83



## NOTES

A large, empty rectangular box with a thin black border, intended for taking notes.

## APPENDIX A DEFINITIONS

**Masonry wall** means an assemblage of masonry units joined together with mortar or grout. Masonry units may be either solid or hollow, and of brick or block size<sup>1</sup>.

**Block** means any masonry unit having dimensions, which satisfy any one of the following conditions:

- a) length between 300mm and 650 mm;
- b) width between 130mm and 300 mm; or
- c) height between 120mm and 300 mm.

**Brick** means any masonry unit which is not a block. A masonry unit having dimensions, which satisfy all of the following conditions:

- a) length not more than 300 mm;
- b) width not more than 130 mm; and
- c) height not more than 120 mm.

**Hollow masonry unit:** A masonry unit containing cavities in excess of 25% but not exceeding 60%, of the gross volume of the unit<sup>1</sup>.

**Masonry accessories:** These include masonry anchors, connectors and ties other than wall ties; shelf angles and their fixings; wall ties that transmit shear; and bed joint mesh<sup>1</sup>.

**Masonry unit:** A unit of a rectangular shape and that is intended for use in the construction of bonded masonry walling<sup>1</sup>.

**Solid masonry unit:** A masonry unit either containing no cavities or containing cavities not exceeding 25% of the gross volume of the unit<sup>1</sup>.

### Types of masonry

**Prestressed masonry:** Masonry in which pre-tensioned or post-tensioned steel is incorporated to enhance resistance to tensile or shear forces<sup>1</sup>.

**Reinforced masonry:** Masonry in which steel reinforcement is incorporated to enhance resistance to tensile, compressive or shear forces<sup>1</sup>.

### Types of reinforced masonry

**Grouted-cavity masonry:** Two parallel single-leaf walls spaced at least 50 mm apart, effectively tied together with wall ties. The intervening cavity contains steel reinforcement and is so filled with infill concrete or grout as to result in common action with the masonry under load<sup>1</sup>.

**Reinforced hollow blockwork:** Hollow blockwork that is reinforced horizontally or vertically (or both) and subsequently wholly or partly filled with concrete<sup>1</sup>.

<sup>1</sup> SANS 10164-2 (See Appendix B)



## APPENDIX B REFERENCES

### STANDARDS AND CODES OF PRACTICE ON THE USE OF CONCRETE MASONRY

#### MANUFACTURE OF CONCRETE MASONRY UNITS

SANS 1215 – 1984 Concrete masonry units

#### USE OF MASONRY UNITS

##### Planning, design and specifications

SANS 993-1972

Modular coordination in building

SANS 10021-2002

Waterproofing of buildings

SANS 10155-1980

Accuracy in buildings

SANS 10249-1993

Masonry walling

NBRI R/Bou – 602

Fire resistance ratings – wall constructed of concrete blocks

##### Building Regulations

National Building Regulations and Building Standards Act 1977 revised 1990

SANS10400-1990

Application of the National Building Regulations

National Home Builders Registration Council Home Building Manual

##### Structural Design

SANS 10100-1:2000

The structural use of concrete

Part 1: Design

SANS 10160 -1989

The general procedures and loadings to be adopted for the design of buildings.

SANS 10161-1980

The design of foundations for buildings

SANS 10164.

The structural use of masonry

Part 1-1980: Unreinforced masonry walling

Part 2-2003: Reinforced and prestressed masonry walling

SANS 1504-1990

Prestressed concrete lintels

Crofts, FS: Lane JW Structural concrete masonry, a

design guide.

#### Concrete Masonry Construction

SANS 073-1974

Safe application of masonry-type facings to buildings

SANS 10145-2000

Concrete masonry construction

SANS 10155-1980

Accuracy in buildings

### MATERIALS OF CONSTRUCTION

#### Aggregates

SANS 794-2002

Aggregates of low density

SANS 1083-2002

Aggregates from natural sources – aggregates for cement.

#### Cement

SANS 50197-1:2000

Cement

Part 1: Composition, specifications and conformity criteria, for common cements.

SANS 50413-1:1994

Masonry cement

Part 1: Specification.

SANS 1491-1989

Portland cement extenders

Part 1: Ground granulated blastfurnace slag.

Part 2: Fly ash.

Part 3: Condensed silica fume.

#### Dampproof courses

SANS 248-1973

Bituminous dampproof course

SANS 298-1975

Mastic asphalt for dampproof courses and tanking

SANS 952-1985

Polyolefin film for dampproofing and waterproofing in buildings

#### Reinforcement

SANS 190-2:1984

Expanded metal

Part 2: Building products

SANS 920-1985  
Steel bars for concrete reinforcement

Lintels

Design guide  
Technical note

SANS 1024-1991  
Welded steel fabric for reinforcement of concrete

Build your house

Step by step with building plans

### **Sealants**

SANS 110-1973  
Sealing compounds for building industry, two-component, polysulphide base

SANS 1077-1984  
Sealing compounds for the building and construction industry, two component polyurethane base

SANS 1305-1980  
Sealing compounds for the building industry, one-component silicone-rubber base

### **Lime**

SANS 523-2002  
Limes for use in building

### **Sand**

SANS 1090-2002  
Aggregates from natural sources. Fine aggregate for plaster and mortar

### **Wall ties**

SANS 28-1986  
Metal ties for cavity walls

## **USEFUL BRITISH STANDARDS**

BS 1014-1975 (1986)  
Pigments for portland cement and portland cement products

BS 4551-1998  
Methods of testing mortar, screeds and plasters

BS 4887  
Mortar admixtures  
Part 1: 1986:  
Specification for air-entraining (plasticizing) admixtures  
Part 2: 1987:  
Specification for set-retarding admixtures

BS 6477-1984  
Water repellents for masonry surfaces

## **CONCRETE MANUFACTURERS ASSOCIATION PUBLICATIONS**

Masonry Manual 6<sup>th</sup> edition

Free-standing walls Design guide  
Technical note: Unreinforced  
Reinforced



## APPENDIX C ANCHORS – WALLS

Anchors are used for tying metal straps, angles and wall accessories to masonry, concrete or steel, at wall/concrete, wall/wall, wall/steel intersections, or to support a leaf of a wall or service. Anchors function by being held in position in the base material by friction, keying, bonding or a combination of these factors. Essentially the fixing of anchors to any member requires either the drilling of a hole to house the anchor, or the firing of the anchor into the supporting material.

In general terms shot-firing anchors into brittle material such as concrete or masonry may shatter the material and the quality of support may then become suspect. Drilling is preferable where anchorage stress level is significant.

Firing into ductile materials such as steel or timber is an easy and quick method of anchoring.

In both cases the amount of force exerted in drilling or shot firing should not disturb the bonding of masonry units to adjacent units.

The position of the anchor is important in ensuring optimum load carrying capacity.

In the case of angles supporting a non-structural

outer leaf of a wall to the main structure then the position of the hole in the vertical leg of the angle should be as near the top of the angle as possible. It is also preferable to use an unequal angle with the longer leg of the angle in the vertical direction.

With straps holding walls to columns to provide lateral support, the anchor should be placed as near as possible to the right angle bend in the strap. This is to prevent the straightening out of the bend, with, say, shrinkage of the wall, which would tend to lift the masonry unit above the horizontal section of the strap, opening the bedding joint.

Normally a single anchor in the vertical leg of the strap is adequate but if two anchors are necessary then the spacing of these anchors should be such as not to reduce the overall anchorage. When shot firing into brittle materials the spacing should be at least 100 mm.

Heated drawn steel should be used for straps that are bent and twisted. Normally stainless steel cannot be shaped to the required shape.

The type, size and position of anchorage to be shown on drawings and/or clearly specified.

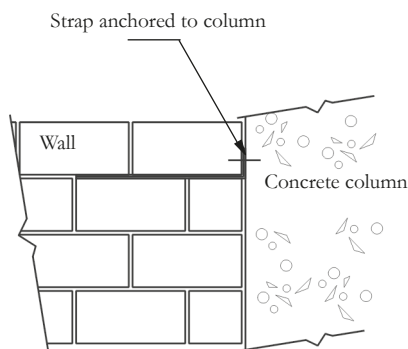

**TYPICAL SECTIONAL ELEVATION  
STRAP FIXED TO COLUMN**

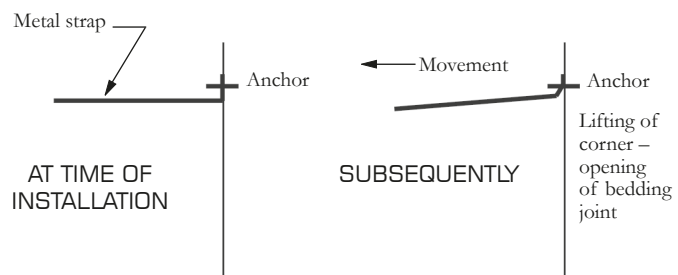

**DIAGRAMATIC SKETCH OF STRAP  
MOVEMENT WITH MASONRY  
SHRINKING AWAY FROM COLUMN**

## APPENDIX D ROOFING FIXING

### Types of Anchor (refer SANS 10400-K)

Roof Slope, Degrees	Max Roof Truss, Rafter or Beam spacing mm	Type of anchor required	
		Light Roof	Heavy Roof
Less than 15	760 1050 1400	A, B or C B or C C	Not Applicable
15-30	760 1050 1400	A, B or C B or C C	Type A for all applications
Greater than 30	Any	A, B or C	

### Anchors

Type A: 2 Strands 4 mm Galvanised Steel Wire Type B: 30 mm x 1.2 mm Galvanised Steel Strap Type C: 30 mm x 1.6 mm Galvanised Steel Strap	
Length of Anchorage	Type of Roof
300 mm	Heavy roof (Concrete or clay tiles or slate)
600 mm	Sheeted Roof

#### Note:

Details of types of anchors apply to buildings not exceeding two storeys in height and where span of the roof truss does not exceed 10 m.

## APPENDIX E: TIES, STRAPS AND BEDDING REINFORCEMENT

### DETAILS OF REINFORCEMENT USED IN BEDDING JOINTS

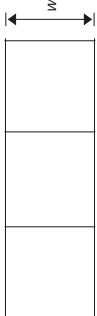
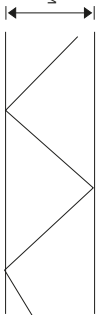
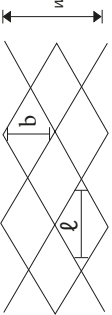
Type	Ladder Type	Truss Type	Mesh/Lathing for reinforcement and tying intersecting leaves of wall
Description	Two longitudinal wires with transverse wires	Two longitudinal wires with diagonal transverse wires.	Diagonal flat expanded metal with diamond shape openings
Sketch			
Width (w), mm	75/150/230	60/110/160	65/75/125
Diameter of wire, mm	2,5/2,8/3,15/3,55	3,25/3,55	0,8 mm thick plate
Wire spacing (s), mm		50	
Size of opening b x l, mm			10 x 30
Length rolls, m	20/25		100
Length flats, m	3	3	Cut to 250 mm
Size of sheet, m x m			1,2 x 2,4
Note:	Wire manufactured for bedding joint reinforcement from high tensile steel should preferably be flat i.e. not in rolls.	Only available flat	Dimension and properties to be confirmed with local supplier. Consider stronger ties is lateral load transfer is significant

Check availability and quality. For quality, check if commercial or stated quality, whether mild, galvanised or stainless steel, or coated for corrosion resistance.

## DETAILS OF REINFORCEMENT USED IN BEDDING JOINTS

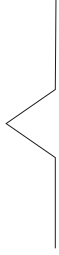
	Hoop Iron		Straps	Rods/Bars	Wall Ties
Purpose	Anchoring roof crusses to walls	Wall to wall sliding joints (Concertina strap) 	- Anchoring concrete and steel columns to walls - Anchoring walls to wall/ sliding joint - wall to wall sliding joints	Reinforcement of: - bedding joint - hollow unit core - cavity Bars can be used in place of straps for anchorage	Connecting two leaves of a cavity wall to ensure that the wall acts as a unit in resisting applied loads - In multileaf walls ensures monolithic action - In diaphragm walls provides shear transfer between web and flange
Material	Normally cut from offcuts of steel - regarded as commercial quality		Normally cut from flat steel sheets - regarded as stated quality	Mid steel or high tensile steel. May be stainless steel or coated for corrosion resistance	Material determined by the likelihood of corrosion viz. galvanised mild steel, copper, copper-zinc or austenitic stainless steel
Shape	Flat	Concertina at joint	Flat	Round, smooth, deformed or indented	Of various shapes
Thickness, mm	1,2/1,6	1,2/1,6	2,5/3,0		1,5 4,0
Width, mm	30	20 30 40	30 40		13 20
Diameter, mm					2,8 3,15 4,0 4,5
Fixing	One end of strap embedded in concrete in core of unit or in bedding joint mortar, other end fixed to roof truss or wall plate See Appendix D	Both ends embedded in mortar joint	One end of strap embedded in concrete in core of unit or in bedding joint mortar, other end fixed by shotfiring bolts/pins into steel or drilling and bolting into concrete  For sliding joints, one end greased	Placed in: - bedding joint - core hollow unit - bond and U-beams - cavity walls and filled with mortar or infill concrete	Placed in bedding mortar  General requirements for provision of ties  Size of cavity Ties/m <sup>2</sup>
					< 75 mm 75 - 100 mm 100 - 150 mm 2,5 3 5

Check material providing connection between structural masonry elements can safely transfer loads and forces while providing lateral support.

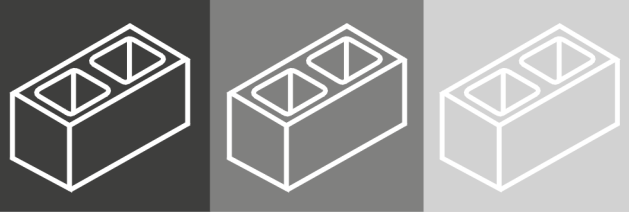

## APPENDIX F DETAILING PRACTICE FOR REINFORCED MASONRY

R B Watermeyer Pr. Eng. B Sc Eng, MSAICE,  
MSAConsE Soderlund & Schutte Inc.

### 1. INTRODUCTION

Drawings depicting details of reinforcement in masonry elements, supplemented by specifications are required to translate designs into physical realities. Detailing is therefore the most important link between good design and quality construction. Accordingly detailing of reinforcement should be kept simple, clear and practical while drawings should clearly define and depict the design requirements in a comprehensible manner. SANS 10164-2 offers guidance in this regard, the main provisions of which are highlighted and illustrated hereunder.

Reinforcement should be located to suit simple masonry bonding patterns. Cutting of masonry units should be kept to a minimum while the bonding of masonry should be such that an adequate void for grouting is maintained. Common practical bonding arrangements are illustrated below.

The detailing of reinforced masonry differs somewhat to that of reinforced concrete; the principle differences being:

- distribution steel is not required in certain masonry bonding patterns since bonded masonry can often span and distribute forces between reinforcing bars.
- reinforcing bars often have to be protected against corrosion in reinforced masonry applications where mortar infill is employed.
- the characteristic anchorage bond strength between mortar and steel is significantly less than that between concrete and steel.

### 2. MORTAR AND CONCRETE INFILL (SANS 10164-2; CI 5.4)

Only Class I and Class II mortar (refer to SANS 10164-1) should be used in the bedding course for reinforced masonry applications. Where masonry cement is used, the bond between steel and mortar should be investigated.

Infill concrete should be grade 25 concrete or better. Mixes should have adequate workability with a slump of between 75 and 175mm. The nominal aggregate in such concrete should be at least 5 mm less than the permitted cover to any reinforcement.

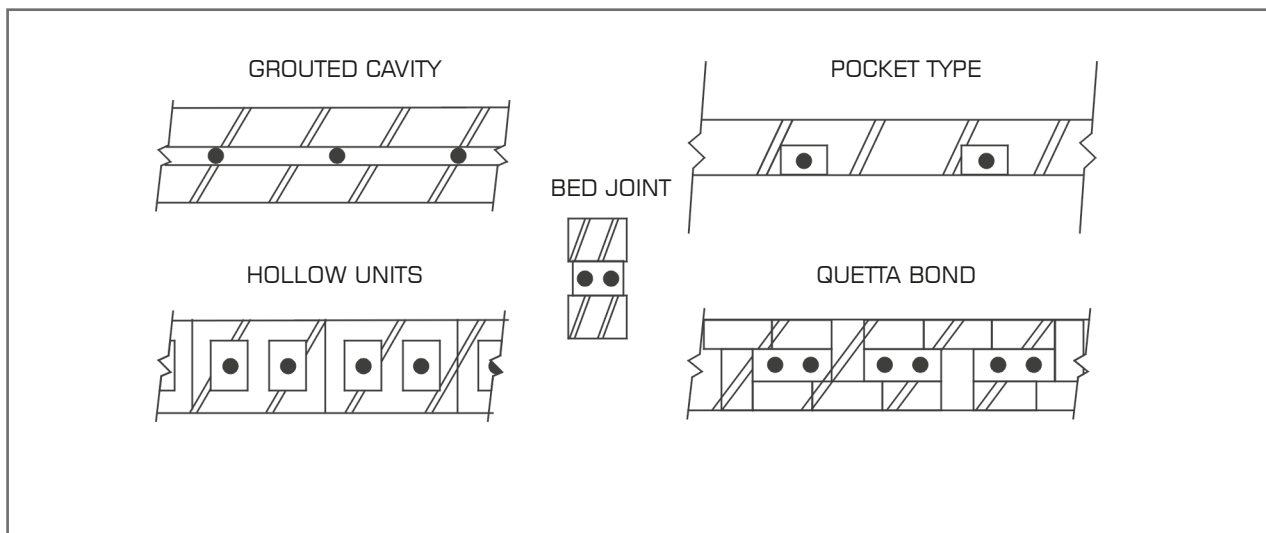

### 3. DETAILING RULES (SANS 10164-2; CI 7.6)

#### 3.1 Main and secondary reinforcement

The main provisions of SANS 10164-2 which relate to the manner in which steel is located in reinforced elements is summarised in Table 1.

**Table 1: Detailing of main and secondary reinforcement**

LOCATION OF STEEL WITHIN ELEMENT	MAXIMUM BAR SIZE mm	SECONDARY REINFORCEMENT <sup>+</sup>	MAXIMUM BAR SPACING mm	SPECIAL PROVISIONS
Grouted cavity	25	$A_s > \frac{0,05 bd}{100}$	500	<u>Low lift construction</u> Provide ties in accordance with SANS 10164-1 <u>High lift construction</u> Provide purpose made ties in accordance with Appendix A of SANS 10164-2
Pockets	32	Not required <sup>#</sup>	No upper limit	Only one bar may be used if pocket is less than 125 mm x 125 mm
Quetta bond	25	$A_s > \frac{0,05 bd}{100}$	500	Only one bar may be used if core is less than 125 mm x 125 mm
Cores of hollow units	25	$A_s > \frac{0,5 bd}{100}$	500	Only one bar may be used if core is less than 125 mm x 125 mm
Bed joints	6#	Not applicable	Not applicable	Wall has enhanced lateral resistance if $A_s > 14\text{mm}^2$ is provided at vertical centres $\nless 450$ mm

\* Prestraightened hard drawn wire with a minimum proof stress of 485 N/mm<sup>2</sup> as supplied by a manufacturer of welded steel fabric reinforcement is suitable for such reinforcement. (Standard bar diameters are 3,5;4 and 5,6);

+ b = breadth of section; d = depth to neutral axis.  $A_s$  = cross sectional area of reinforcement.

# Distribution steel is not required since bonded masonry, particularly in the horizontal direction, can span and distribute forces between reinforcing bars. However, distribution steel may be required to control shrinkage.

Usually reinforcement acts in tension. However, where reinforcement acts in compression, such reinforcement must be restrained against the tendency to buckle. This achieved by the inclusion

of secondary steel reinforcement in the form of distribution steel, links or binders.

In all cases, the minimum clear horizontal or vertical distance between parallel bars should be as follows:

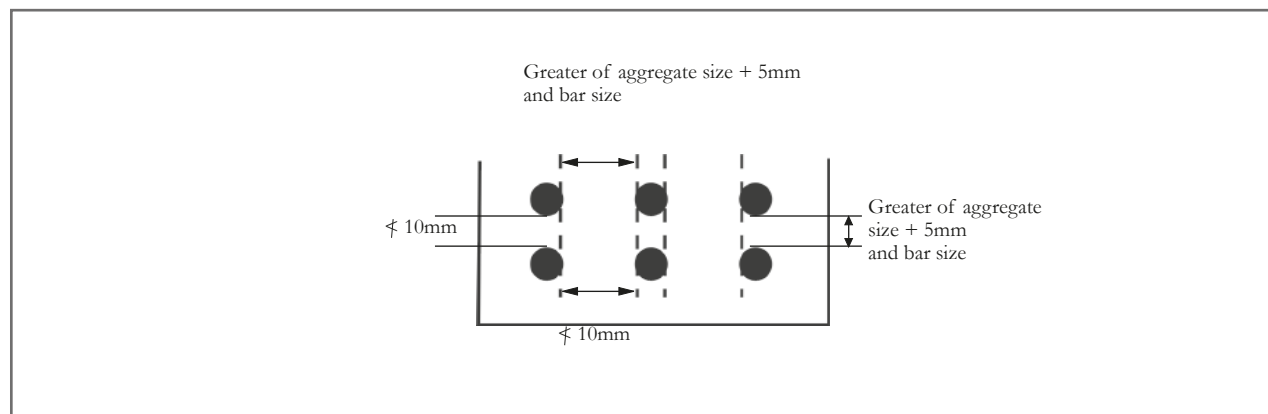

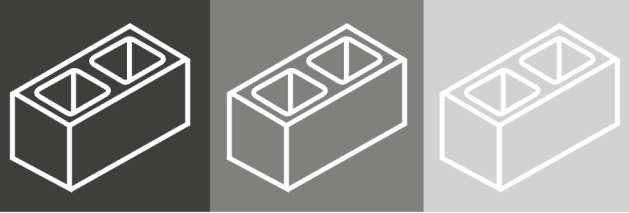

## 1.2 Anchorage bond, laps and joints

For reinforcement to develop the design stress, it must be adequately bonded into the surrounding masonry. This may be achieved by ensuring that:

- the cover of concrete or mortar infill is at least equal to the bar diameter; and
- a sufficient length of bar (anchorage length) extends beyond any section to develop the necessary force at that section.

The length of bar required for anchorage purposes may be calculated as follows:

$$l_{ba} = \frac{f_y \gamma_{mb} \phi}{4 \gamma_{ms} f_b} = K \phi$$

where:

$\phi$  = nominal bar diameter

$\gamma_{mb}$  = partial safety factor for bond strength

$\gamma_{ms}$  = partial safety factor for strength of steel

$f_b$  = characteristic anchorage bond strength

$f_y$  = characteristic tensile strength of reinforcing steel

$A_s$  = cross sectional area of steel

$K$  = ratio of anchorage bond length to bar diameter (see Table 2)

$$\text{Thus } l_{ba \text{ required}} = K \phi \frac{A_{s \text{ required}}}{A_{s \text{ provided}}}$$

**Table 2: Ratio of anchorage bond length to bar diameter**

TYPE OF REINFORCEMENT	CHARACTERISTIC TENSILE STRENGTH MPa	RATIO OF ANCHORAGE BOND LENGTH TO BAR DIAMETER (K)*			
		Mortar Infill		Concrete Infill	
		Tension	Compression	Tension	Compression
Hot rolled mild steel plain bar as in SANS 920	250	51	42	42	35
Hot rolled high yield deformed bar as in SANS 920	450	68	57	55	45
Hard drawn steel wire as in SANS 1024	485	98	82	82	68
Stainless steel grades 304515, 316531 and 316533 as in BS 970-1	460	93	77	78	65
- plain bar - deformed bar		70	58	56	46

The effective anchorage length of a hook or bend, measured from the start of the bend to a point four times the bar size beyond the end of the bend should be taken as the lesser of:

- 24 times the bar size.
- 8 times the internal radius of a hook.
- 4 times the internal radius of a 90 degree bend.

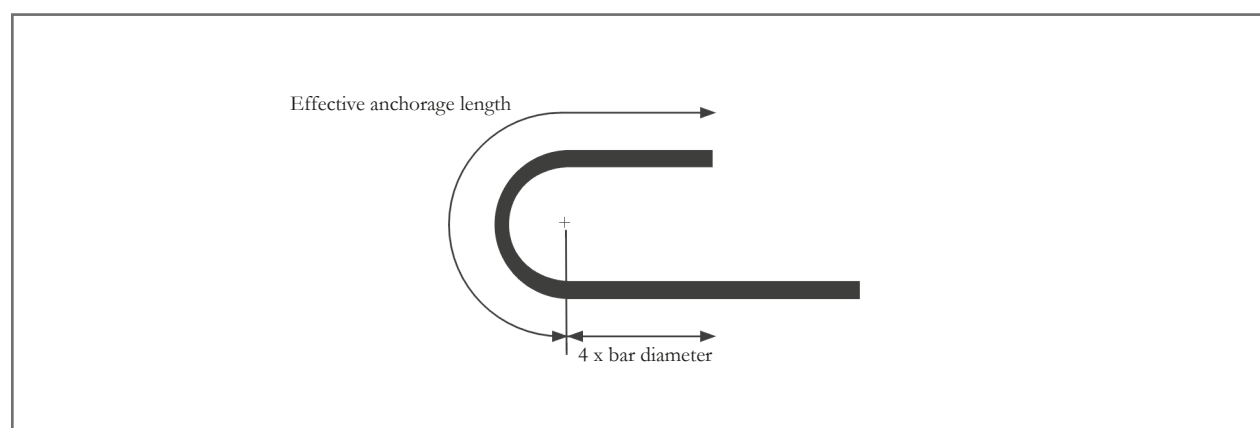



**Note:** Minimum radius of any bend  
 =  $2 \phi$  (mild steel)  
 =  $3 \phi$  (high yield steel)

The beginning of hooks should be located inside the face of support as follows:

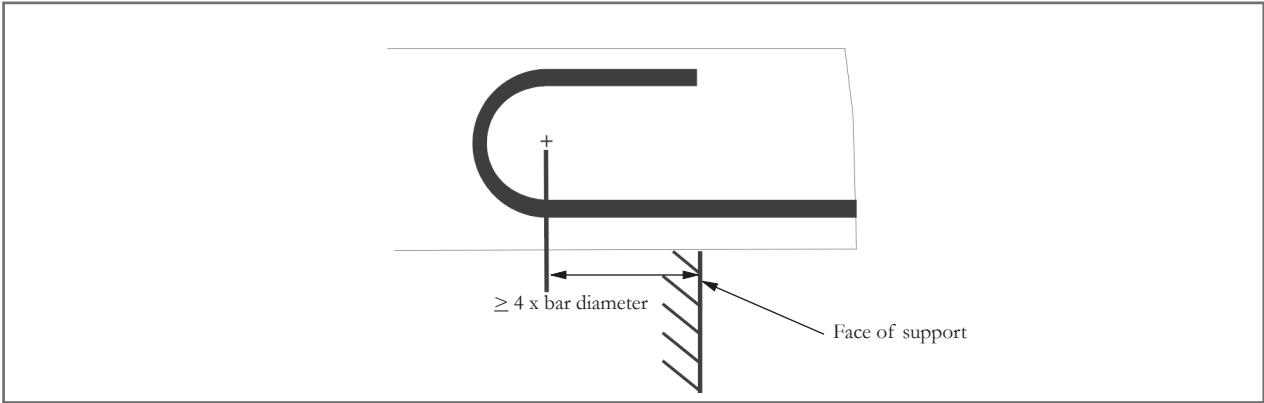

Joints in reinforcement may be achieved by means of mechanical couplers or simply by lapping reinforcing bars of follows:

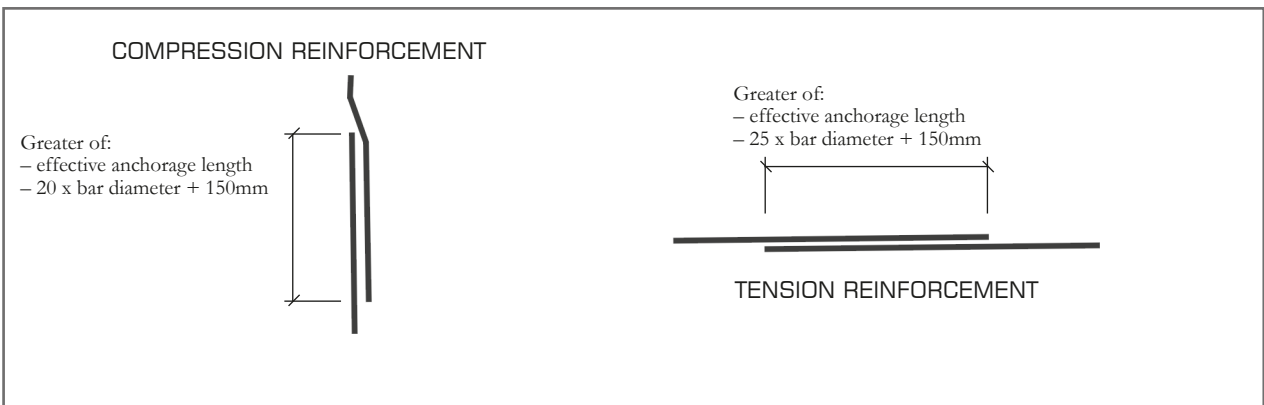

Generally, laps should be located away from areas of high stress and should be staggered. Account of the construction sequence, build-ability, stress considerations, congestion of reinforcement etc. , should be taken in the location of laps and joints.

### 1.3 Links

Links may be required to restrain reinforcement acting in compression or to provide shear reinforcement. Links may only be considered to be fully anchored if they are detailed as follows:

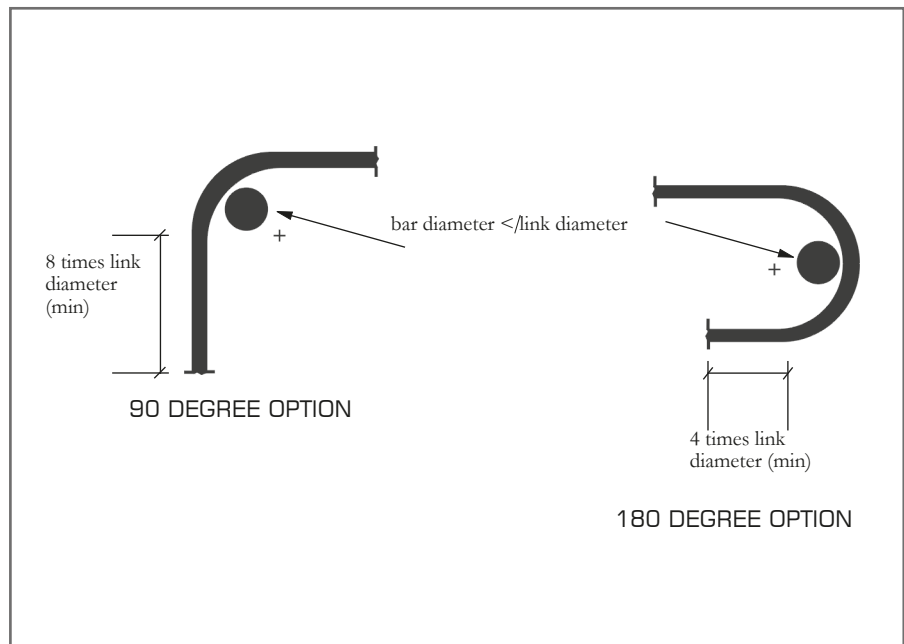

Shear reinforcement links in beams should be provided as follows:

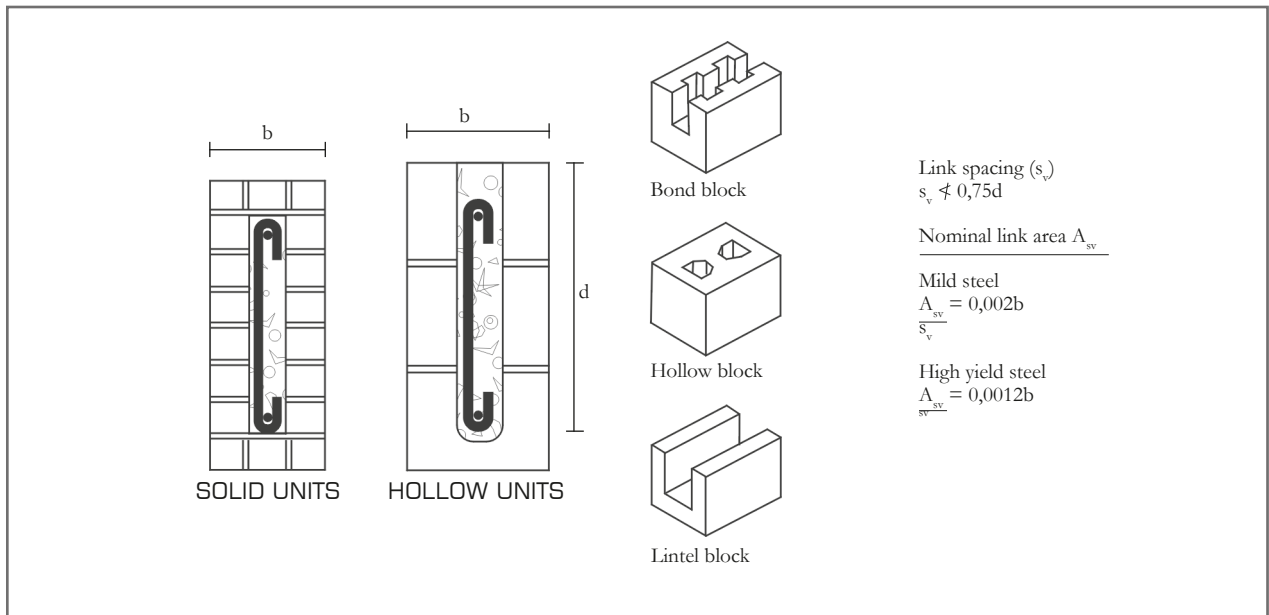

Where compression steel is used in beams, links should be provided as for columns. Column links are required when the area of steel exceeds 0,25% of the gross area of the column and the design load exceeds 25% of the resistance capacity of the column. In such circumstances, links should be provided as follows:

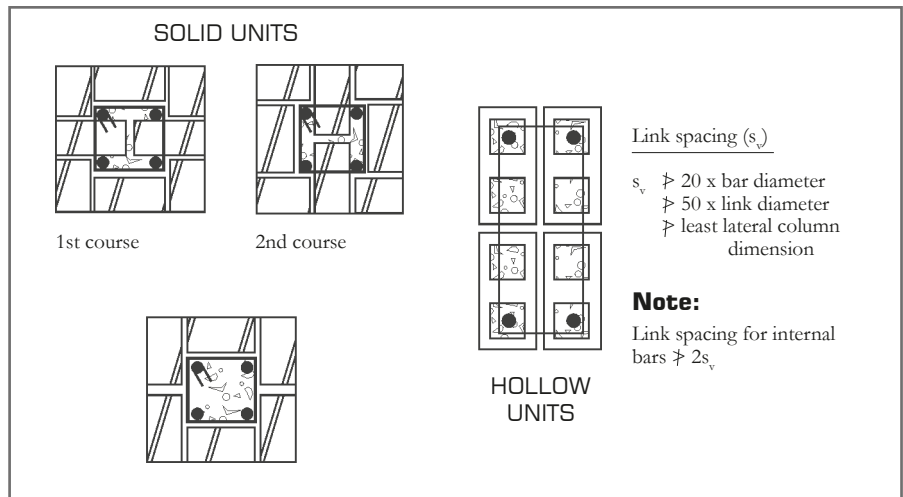

### 3.4 Curtailment of bars

Reinforcing bars acting in tension at simply supported ends of members should be terminated as follows:

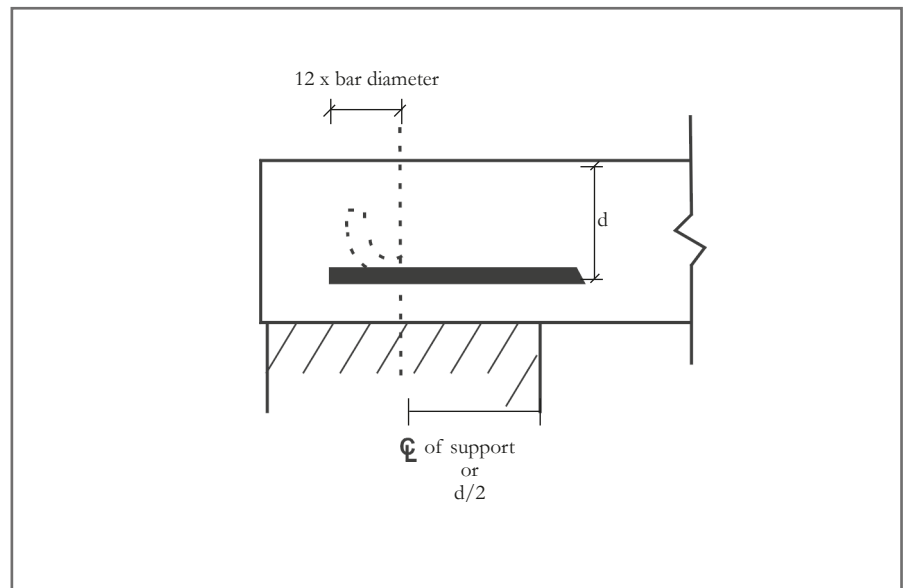



However, should the distance between the face of the support and the edge of the nearest principal load be less than twice the effective depth, reinforcement should be curtailed as follows:

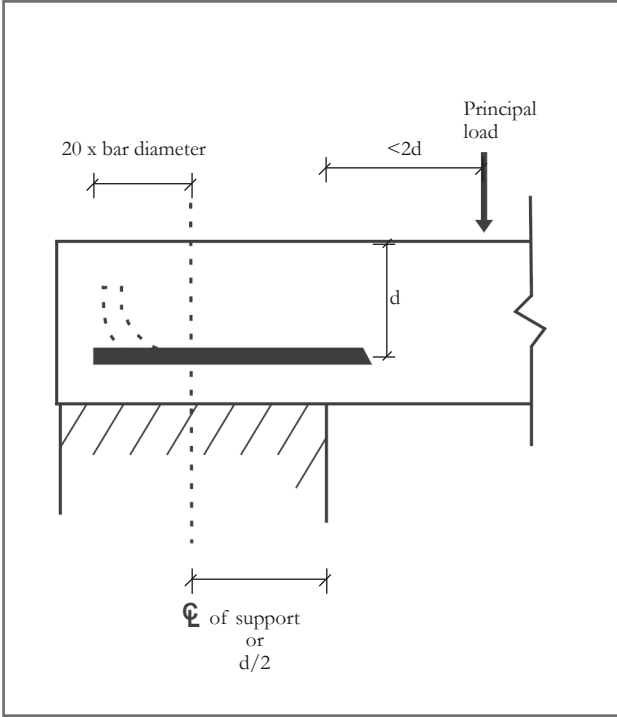

Reinforcing bars which are subjected to bending and terminate other than at an end support, should continue for a distance beyond the point at which they are no longer required, equal to the greater of the effective depth of the member or 12 times the bar size, provided, however, that one or more of the following is satisfied:

- bars extend for a distance at least equal to the effective anchorage bond length;
- the design shear strength of the section is at least twice that of the applied shear force;
- the remaining reinforcement provides at least twice the area of reinforcement required to resist the applied bending moment.

## 4. RESISTANCE OF METAL COMPONENTS TO CORROSION (SANS 10164-2; CI 9.2)

### 4.1 General

The resistance of metal components to corrosion depends upon the following:

- exposure environment
- type and quality of cementitious surround, i.e., mortar or infill concrete
- cover
- type of protective coating of steel.

EXPOSURE CLASSIFICATION	EXPOSURE ENVIRONMENTS FOR SURFACES OF REINFORCED MEMBERS
E1	Protected by an impermeable membrane Exposed to the elements in ■ inland areas as shown in Figure 1. ■ interiors of buildings. Beneath coatings that resist moisture penetration.
E2	Exposed to the elements in: ■ inland areas as shown in Figure 1. ■ interiors of industrial buildings where humidity is high or where repeatedly washed. Submerged in non-aggressive soils.
E3	Exposed to the elements in: ■ areas within 3 km of industries that discharge atmospheric pollutants. areas within 1 km of the coastline or shoreline of large expanses of salt water. Submerged in fresh water.
S	Submerged in aggressive soils. Submerged in sea water, running water or soft water. In contact with corrosive liquids or gas.

SANS 10164-2 contains recommendations regarding the minimum levels of protective coatings for reinforcement and masonry accessories used in various types of construction and exposure conditions. These recommendations are not necessarily the desirable levels of protection that may be required since local conditions or specific circumstances may warrant a higher degree of protection.

### 4.2 Exposure classification

The exposure classification may be established from Table 3 and Figure 1 or Table 17 of SANS 10164-2. Elements which may be subjected to more severe exposure than the remainder of a building, such as parapets, chimneys and sills should be regarded as being located in an environment classified as E3.

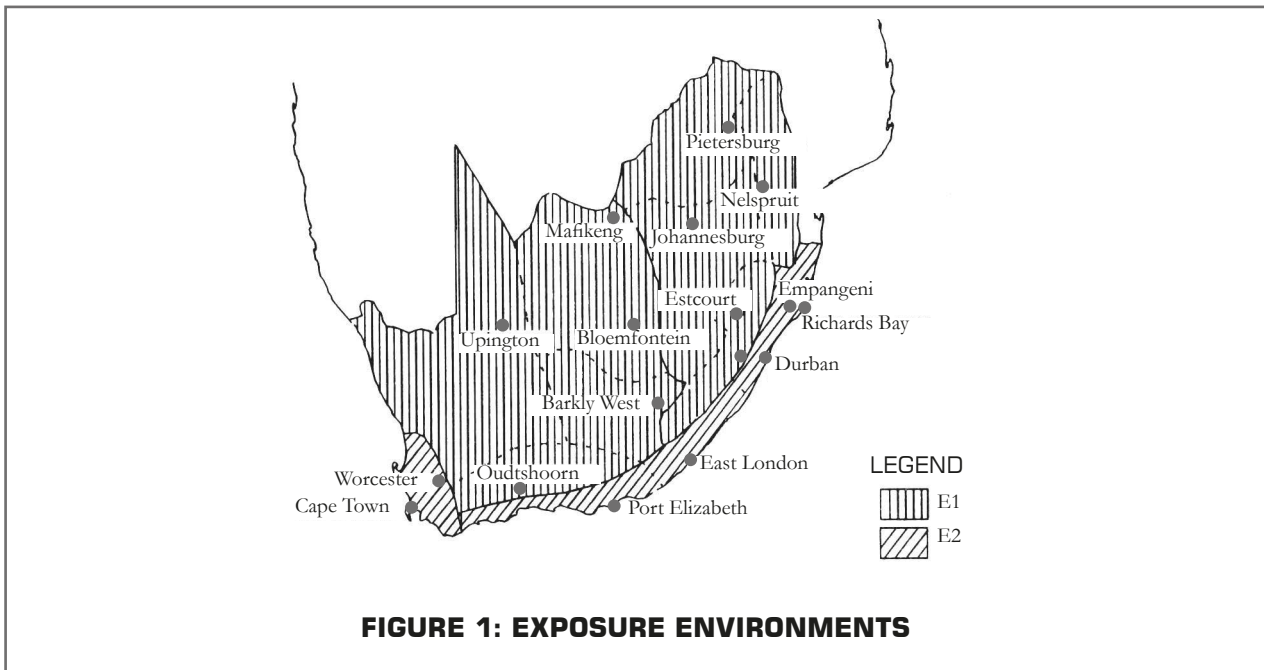

### 4.3 Corrosion protection

The degree and type of corrosion protection required, if any, for various types of steel should be determined in accordance with Table 4, read in conjunction with Table 5. The zinc coating on galvanised steel ties should be at least equal to that in Table 2 of SANS 935 for normal environments and 470 g/m<sup>2</sup> for highly corrosive environments.

**Table 4 : Corrosion-resistance rating for steel in masonry**

<b>CORROSION-RESISTANCE RATING</b>	<b>TYPE, OR COATING, OF STEEL (OR BOTH)</b>
C1	Uncoated carbon steel; or steel whose coating is less than required for C2 rating.
C2	Galvanized steel; for products made from: a) sheet steel – the coating class shall be at least Z 275 as in SANS 934; b) wire of circular cross-section up to 6,0 mm diameter – the coating shall be as for class A wire in Table 2 of SANS 935; c) other forms of steel – the coating mass shall be as in Table 1 of SANS 763.
C3	Galvanized steel; for products made from: a) sheet – the coating class shall be at least Z 600 as in SANS 934. b) other forms of steel – the coating shall be as for rating C2.
C4	Steel, or steel coating, whose type and thickness are specially selected to withstand the particular corrosive conditions to which that steel and its masonry may be exposed.

**Table 5: Selection of reinforcement for durability**

LOCATION OF REINFORCEMENT CLASSIFICATION	EXPOSURE RESISTANCE	CORROSION
Located in grouted cavities or in Quetta bond construction a) where concrete infill employed b) where mortar infill is employed	E1, E2 and E3	C1 or higher
	S	C4
	E1	C1
	E2 and E3	C2 or higher
In bed joints	S	C4
	E1	C1 or higher
	E2	C2 or higher
	E3	C3
	S	C4

**4.4 Cover**

Cover to reinforcement should be as follows:

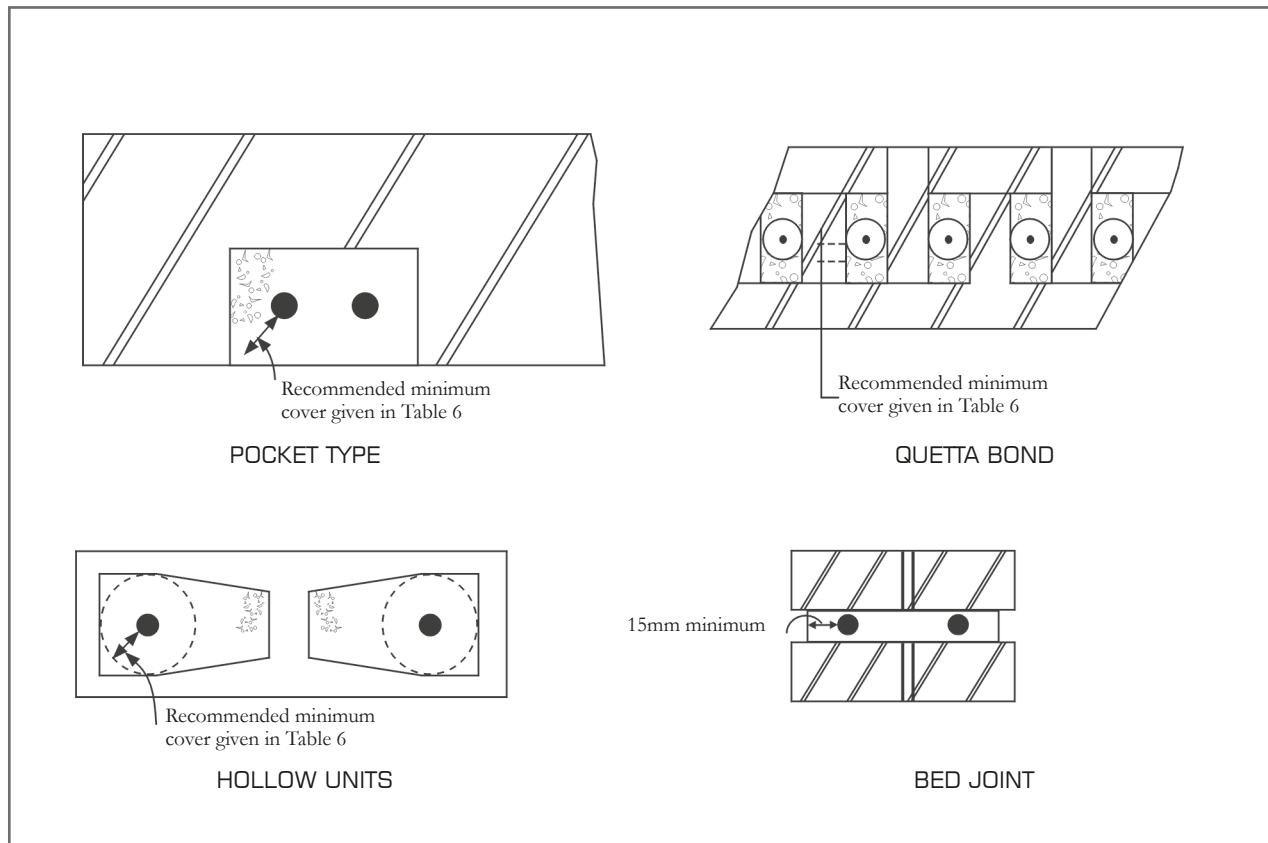



**Table 6: Minimum concrete cover for carbon steel reinforcement**

EXPOSURE CONDITION	MINIMUM THICKNESS OF CONCRETE COVER, mm			
	Concrete grade (as in SANS 10100)			
	25	30	35	40
	Minimum cement content kg/m <sup>3</sup>			
	250	300	350	350
E1	20	20	20	20
E2	-	30	30	25
E3	-	40	35	30
S	-	-	-	60

The tooling of mortar joints gives a dense, water-shedding finish. Tooling of joints should be undertaken in elements located in environments which are classified as E3 or S.

## 5. FIRE RESISTANCE

SANS 10164-2 does not contain any guidance on the fire resistance of reinforced elements and simply makes reference to a code which is still in the course

of preparation. BS 5628 Part 2 (Structural use of Reinforced and Prestressed Masonry) suggests that the masonry itself be considered as part of the cover and that the recommendations of BS 8110 (Structural use of Concrete) be followed. AS 3700 (SAA Masonry Code), on the other hand, specifies a minimum cover to the reinforcement for a specific fire resistance period. (See Table 7).

**Table 7: Protection to reinforcement for structural adequacy (AS 3700)**

FIRE RESISTANCE PERIOD, MINUTES	30	60	90	120	180	240
Minimum dimension from the reinforcement to the exposed face of the masonry, mm	30	30	30	40	55	65

## APPENDIX G V-JOINTS IN PLASTER AND MORTAR

### JUNCTION OF TWO WALLS AT CONTROL JOINT

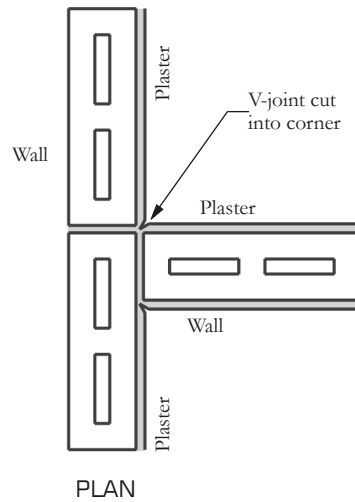

### JUNCTION OF WALL WITH CONTROL COLUMN

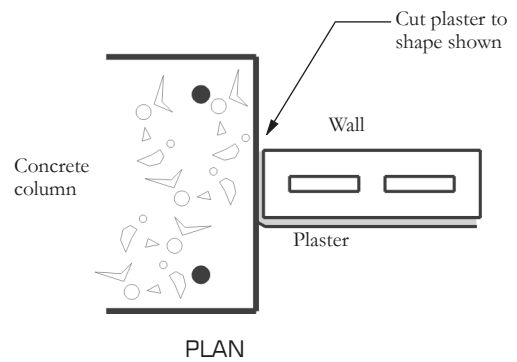
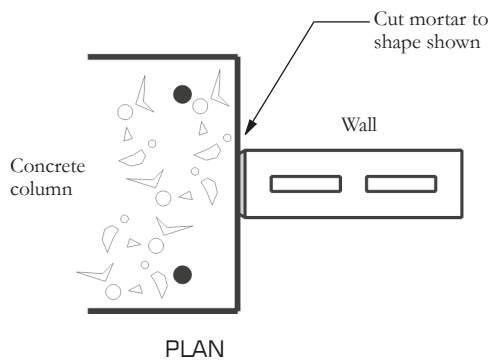



## NOTES

A large, empty rectangular box with a thin black border, intended for taking notes.

## ACKNOWLEDGEMENTS

The assistance of the following organisations in compiling this publication is acknowledged.

FS Crofts  
Hilti  
Institute for Timber Construction Limited  
MITEK  
Soderlund and Schutte  
The South African Institute of Steel Construction  
The South African Lumber Miller Association

### USE OF COMPUTER AIDED DESIGN (CAD)

The drawings in this manual are available on CD in various CAD formats.

Please contact the Concrete Manufacturers Association if you require this disc.

## MASONRY PRODUCER MEMBERS (MAY 2011)

A Fick Cement Works	022 913 1921
Bafokeng Technicrete	014 538 0818
Boland Concrete	021 875 5365
Brick & Concrete Industries (Namibia)	00264 61 321 3000
Brickcast Industries cc	031 5075525
Cape Brick cc	021 511 2006
Columbia DBL	021 905 1665
Deranco Blocks	041 463 3338
Inca Concrete Products	021 904 1620
Inca Masonry Products	043 745 1215
Lategan's Cement Works	021 873 1154
Neat Contech	046 624 3377
Panda, Botswana	00267 244 2106
Stanger Brick & Tile	032 457 0237
Technicrete	011 674 6900
Watston Concrete	011 740 0910
West End Cement Bricks	011 851 1098
Western Granite	021 904 1620

Members list above correct at the time of going to print.



Block D, Lone Creek, Waterfall Office Park, Bekker Road, Midrand  
PO Box 168 Halfway House 1685  
Tel +27 11 805 6742, Fax +27 86 524 9216  
E-mail: main.cma@gmail.com, Website: www.cma.org.za

## DETAILING OF CONCRETE MASONRY

Volume 1 – Solid Units 140mm



Concrete masonry:  
Strong, durable and attractive



## DETAILING OF CONCRETE MASONRY

Volume 2 – Hollow Units 140/190



Concrete masonry:  
Strong, durable and attractive



## DETAILING OF CONCRETE MASONRY

Volume 3 – Cavity Walls 240 to 290

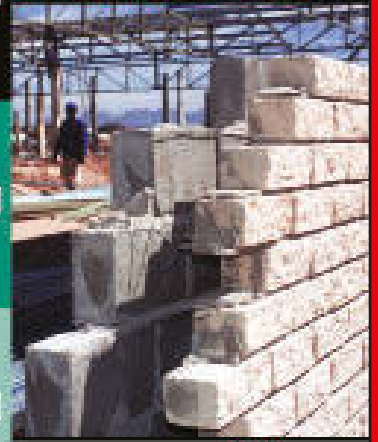

Concrete masonry: Strong,  
durable and attractive

