



Putting a Roof
over your head

TOTAL ROOFING SOLUTIONS FROM GRS

Global Roofing Solutions is one of the largest independent roofing companies registered in South Africa and consists of two leading South African roofing material manufacturers, Brownbuilt Metal Sections (established in 1964) and HH Robertson (established in 1958). Brownbuilt is known for pioneering concealed fix sheeting in Southern Africa and HH Robertson first registered "IBR", making it a generic name in roofing. GRS is 25% Black Economic Empowered through an investment by Mediro Industrial Holdings, a well placed and broadbased empowerment company with investments in a number of large manufacturing concerns. Both Brownbuilt and HH Robertson are household names for the manufacture and supply of commercial and industrial steel roofing and wallcladding profiles (concealed and pierced fix), permanent formwork/steel decking and lightweight coated metal tiles (Armatile & Armashake).

Their sister operation in the GRS fold, Coilcoat, is an in-house coil coating facility servicing the group with a range of Globalcoat™ paint systems, as well as other manufacturers and other users of pre-painted sheetmetal such as cold room, garage doors, signage, and other fabricators.

With exports to over 20 countries worldwide, GRS is establishing itself as a global supplier of roofing products. Through its broad South African design and manufacturing base, the group plans to establish manufacturing facilities and licensees throughout Africa.

Global Roofing Solutions' manufacturing operations, Brownbuilt Metal Sections and HH Robertson, supported by Coilcoat, are your answer for quality roofing and structural floor decking components.

MISSION STATEMENT

"To provide total roofing solutions to the global marketplace"

MANUFACTURING & QUALITY POLICY

"To manufacture and market products which meet and exceed the quality and performance required on the world market."

CAPABILITIES & FACILITIES

- Continuous research and development.
- Roll forming and pressing capacity in excess of 4000 tons per month.
- More than 18 static roll forming mills, producing several million square metres of sheeting and tiles per annum.
- 5 mobile sheet rolling mills for on-site roll forming of long sheeting.
- Extensive design and architectural experience to assist quantity surveyors, contractors and architects with projects.
- In-house coating of metal coils, one of the first such lines in Africa.

CERTIFICATES & MEMBERSHIPS

- ISO 9001:2000 - Certification for quality management.
- Agrément South Africa-certification of selected Brownbuilt and HH Robertson products.
- Instytut Techniki Budowlanej (ITB) Poland approvals for Armatile and Dektile, other EU and USA approvals pending.

FIELDS OF BUSINESS

Manufacturers and suppliers of:

- A range of coated and textured metal roof tiles.
- A range of metal roofing profiles and wall cladding (Concealed fix and Pierced fix).
- A range of floor decking/permanent formwork.
- Coated coils, painted by Coilcoat to customer specifications (Globalcoat™ paint systems supplied by Becker Industrial Coatings, Sweden).

WORLD CLASS PRODUCTS

The roofing products supplied by GRS, are available in various substrates, galvanised steel, Zinalume™ coated steel, stainless steel, aluminium, polycarbonate, GRP (Fibreglass) and other composite materials, with a variety of coloured and textured finishes, such as: embossing, Globalcoat™ paint system (Global-Tech 5000, corrosion resistant Global-Duro, Global PVDF) and 100% Acrylic and Grit / Natural Stone coatings.

METAL ROOF TILES

- Armatile™, Acrylic Grit or Natural Stone coated metal roof tiles.
- Armashake™, an alternative coated metal 'shake' tile.
- Dektile™, a self supporting wide span metal roof tile is available on request.

ROOFING AND CLADDING PROFILES

Concealed Fix

- Kliplik 406™ & 700™, concealed fix, standing seam profiles. On-site rolling capability available in Southern Africa.
- Brownbuilt & Superseal 500 is available on request and for site rolling in Africa.

Pierced Fix

- IBR686 and 890, the well-known 'Inverted Box Rib', bold, angular, trapezoidal roofing profile & NURIB 762, a slightly shallower profile but wider than the standard IBR686.
- Corrugated 10 1/2, S-ribbed Victorian style roof profiles.
- Deklad 550 and BR7 are available on request

FLOORING / PERMANENT FORMWORK SYSTEMS

- Bond-dek, a deep permanent formwork profile, providing an economical floor slab for multi-storey and concrete buildings.
- Bond-lok, a permanent interlocking formwork profile providing a slab with a neat painted or unpainted underside as a ceiling.
- QC Flooring, a permanent shutter and reinforcing system for composite steel and concrete slabs, with a ceiling, painted or ready for painting.

OTHER

- An aesthetically pleasing embossing option (stucco pattern) for all GRS profiles.
- Coil painting line, providing durable coating options for all GRS profiles in the Globalcoat™ paint system.
- Globalcoat™ pre-painted flat metal sheets for various applications i.e. rain water goods, panels, signage etc.

CONCEALED FIX ROOF SHEETING & CLADDING

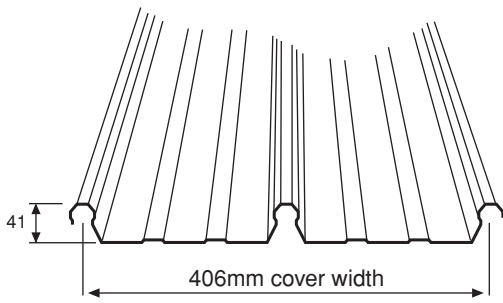

KLIP-LOK 406

A concealed fix profile with unique double interlocking side laps makes this a very fast installing roof sheet. This profile is ideally suited to low roof pitches. Manufactured from certified high yield steel or special grade aluminium making it lighter and stronger.

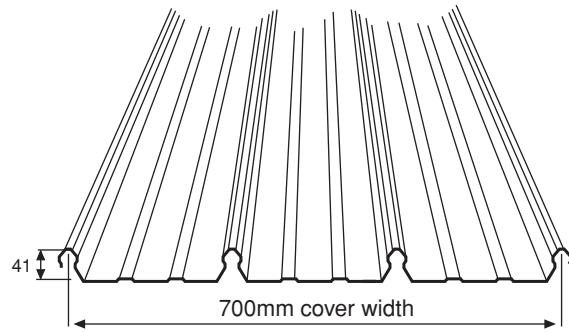

KLIP-LOK 700

Similar to Klip-Lok 406 but wider. This sheet is even faster to install yielding greater savings. This profile is ideally suited to low roof pitches. Manufactured from certified high yield steel making it lighter and stronger.

Translucent sheets for above profiles are available upon request.

“Brownbuilt” and Superseal 500

These classic and well-known concealed fix sheeting systems are available upon request and for site rolling in other countries, subject to minimum order quantities.

PIERCED FIX ROOF SHEETING & CLADDING

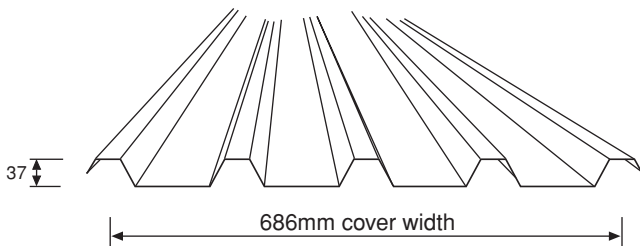

IBR 686

The trapezoidal flute design still offers the optimum strength, mass and load-span characteristics compared to alternative profiles.

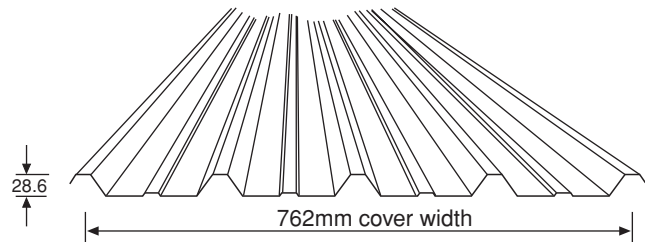

NU-RIB 762

Effectively bridges the gap between Corrugated and the standard IBR686 box ribbed profile

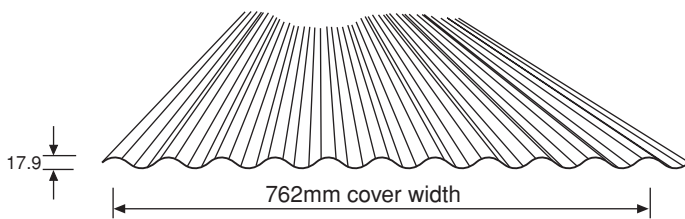

CORRUGATED 10 1/2

Corrugated 10 1/2 has a tranquil appearance, is relatively light, easy to handle and provides an economical coverage per unit mass.

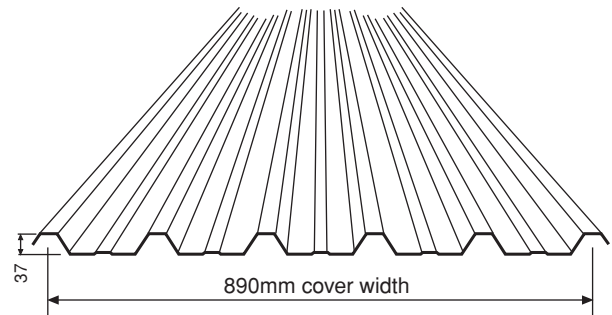

IBR 890 (SUPACLAD)

This wide span trapezoidal profile provides the choice of wider cover and more effective installation, saving on purlins and labour.

DEKLAD 550 & BR7

These classic and specialised pierced fix profiles are available upon request, subject to minimum order quantities.

Translucent sheets for above profiles are available upon request.



Reg No: LS0139

Brownbuilt Metal Sections



ISO 9001:2000
Certificate no: FM77714

HH Robertson

METAL ROOF TILES

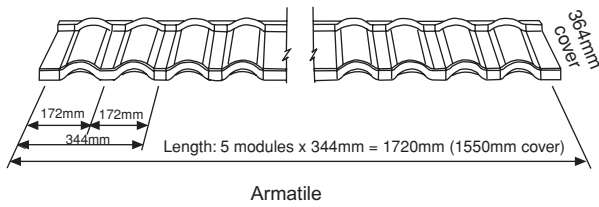

Armatile

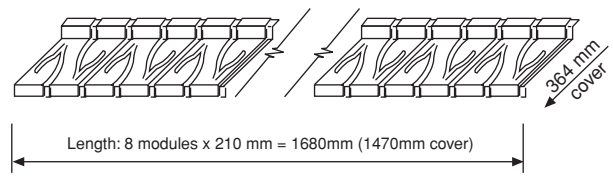

Armashake

ARMATILE / ARMASHAKE

A strong, attractive light weight pressed metal roof tile with either an acrylic grit finish or a natural stone coat finish. The Armatile simulates the well known Double Roman cement tile and the Armashake has a pleasing wooden shake look. Its light weight significantly reduces the quantity of timber required in the support structure and provides for easy installation. These low maintenance, durable tiles are secure, tamper proof, water tight and impact resistant.

DEKTILE

This classic self supporting pre-painted roof tile system is available upon request, subject to minimum order quantities.

PERMANENT FORMWORK (COMPOSITE DECKING) PRODUCT RANGE

The GRS team of designers are available to assist with load-spanning details and specifics, if required.

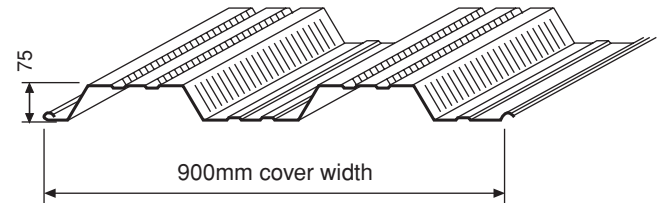
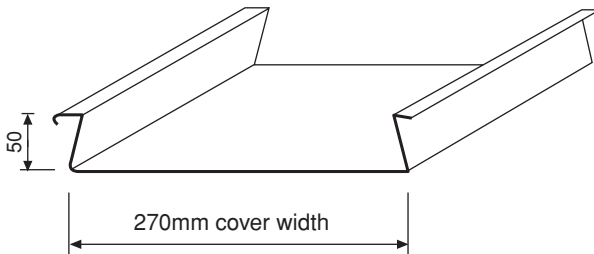

BOND-LOK

A permanent formwork / shuttering which, with concrete, acts as a composite floor slab with an attractive flat ceiling on the underside. This system significantly reduces the number of props utilised and eliminates the need for reinforcing steel. Installation is extremely quick, for a further saving in labour cost.

BOND-DEK

An economical permanent formwork / shuttering which, with concrete, acts as a composite floor slab. This system eliminates the requirement for reinforcing steel. This profile is able to span 3m unsupported under wet concrete thus saving on props. Installation is extremely quick, for a further saving in labour cost.

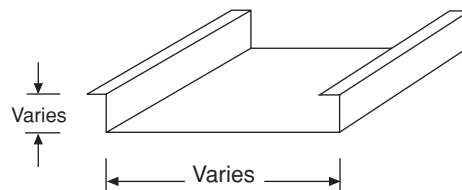
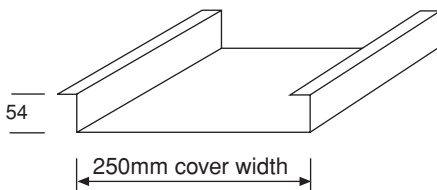

QC FLOORING

QC Flooring is a composite steel and concrete slab system with a neat ceiling, pre-painted or ready for painting. It provides added flexibility in that the cover width may be customised to suit the floor design.

NOTE: Full technical specifications, loads, spanning details and comprehensive CAD details are available for all the above products.

Please contact GRS for further information.



GRS
GLOBAL ROOFING SOLUTIONS

Global Roofing Solutions Corporate:
Head Office: Tel: +27 11 570 4600 Fax: +27 11 974 5683
Brownbuilt: Tel: +27 11 898 2900 Fax: +27 11 892 1455
HHRobertson Tel: +27 11 392 9800 Fax: +27 11 392 2230

Global Roofing Solutions Branches:
Cape Town Tel: (021) 521 1900 Fax: (021) 556 6936
Durban Tel: (031) 700 1414 Fax: (031) 700 1455
East London Tel: (043) 736 3604/5/6 Fax: (043) 736 3626
Bloemfontein Tel: (051) 432 3724/6 Fax: (051) 432 3723

www.global-roofing-solutions.co.za