

## Semi-Framed



## Framed



## Frameless



SA Shower Enclosure  
Manufacturers Association

*G*UIDE

FOR THE

FUNCTIONAL

REQUIREMENTS

AND TEST

METHODS OF

SHOWER

ENCLOSURES

Administered by



AAAMSA  
Group

March 2006



Page 2

P O Box 7861  
HALFWAY HOUSE  
1685

1<sup>st</sup> Floor. Block E  
Construction Park  
234 Alexandra Avenue  
MIDRAND

 (011) 805-5002  
Fax: (011) 805-5033  
Email: [aaamsa@iafrica.com](mailto:aaamsa@iafrica.com)  
Web-site: [www.aaamsa.co.za](http://www.aaamsa.co.za)



**SA Shower Enclosure  
Manufacturers Association**

*All information recommendation or advice contained in this AAAMSA Publication is given in good faith to the best of AAAMSA's knowledge and based on current procedures in effect.*

*Because actual use of AAAMSA Publications by the user is beyond the control of AAAMSA such use is within the exclusive responsibility of the user. AAAMSA cannot be held responsible for any loss incurred through incorrect or faulty use of its Publications.*

*Great care has been taken to ensure that the information provided is correct. No responsibility will be accepted by AAAMSA for any errors and/or omissions, which may have inadvertently occurred.*

*This guide may be reproduced in whole or part in any form or by any means provided the reproduction or transmission acknowledges the origin and copyright date.*

Copyright © AAAMSA 2006

## INDEX

	<b>PAGE</b>
<b>1. Scope</b>	4
<b>2. Normative References</b>	4
<b>3. Definitions</b>	4
3.1 Shower Enclosure	4
3.2 Shower Cubicle	4
<b>4. Requirements</b>	4
4.1 General	4
4.2 Cleanability	4
4.3 Shatter Properties	5
4.3.1 Thermally Toughened Safety Glass	5
4.3.2 Plastic Materials	5
4.4 Durability	5
4.4.1 General	5
4.4.2 Corrosion Resistance	5
4.4.3 Coatings	5
4.4.3.1 Anodising	5
4.4.3.2 Powder Coating	5
4.4.3.3 Electroplating processes	6
4.4.4 Functional Durability	6
4.4.5 Structural Stability	6
4.4.6 Water retention	6
<b>5. Test Methods</b>	
5.1 Thermally Toughened Glass	6
5.2 Functional Durability	6
5.3 Stability	6
5.4 Water Retention	7
Test A	7
Test B	7
Figure 1 – Stability test arrangement	8
Figure 2 – Test shower head	9



## 1. SCOPE

This standard specifies requirements for shower enclosures for domestic purposes, which ensure that the product, when installed in accordance with the manufacturer's installation instruction, gives satisfactory performance when used as intended.

This standard does not apply to shower cabinets or curtains and does not specify aesthetic and dimensional requirements.

Note: For the purposes of this standard the term "domestic purposes" includes use in hotels, accommodation for students, hospitals and similar buildings, except when special medical provisions are required. This standard applies in general to shower enclosures installed for use in buildings having an occupancy class A2, A3, E2, E3, H1, H2, H3 and H4 in terms of SANS 10400:Part A.

## 2. NORMATIVE REFERENCES

This Standard incorporates provisions from other publications. These normative references are cited at the appropriate places in the text and the publications are listed hereafter. For undated references the latest edition of the publication referred to applies.

- SANS 10400 – The application of the National Building Regulations
- SANS 999 – Anodised coatings on aluminium (for architectural applications)
- SANS 1796 – Coatings of durable organic powder for external architectural aluminium
- SANS 1578 – Durable organic powder for coating of external architectural aluminium
- SANS 10160 – The general procedures and loadings to be adopted in the design of buildings
- SANS 1263-1 – Safety and security glazing materials for buildings Part 1: Safety performance of glazing materials under human impact

## 3. DEFINITIONS

For the purpose of this standard, the following will apply:

### 3.1 SHOWER ENCLOSURE

An arrangement of fixed and moving panel(s) and/or door(s) erected on or around a drained shower place, shower tray or bath, either free standing or in conjunction with one or more walls of the main building structure to provide a water retaining area for the purpose of showering.

### 3.2 SHOWER CUBICLE

A prefabricated but not necessarily preassembled unit for the purpose of showering comprising a shower tray or bath and rigid water resistant enclosing wall(s), with or without a roof and with an entry capable of being closed to provide a fully enclosed compartment.

## 4. REQUIREMENTS

### 4.1 GENERAL

The manufacturer shall provide with each shower enclosure detailed instructions on installation and use, to include at least the following information:

- description of installation with special consideration of building construction and necessary tools, sealing etc.;
- instruction for appropriate maintenance and care.

### 4.2 CLEANABILITY

When tested visually, the surfaces of the components of the shower enclosures which are accessible during use and cleaning shall be free from sharp corners, edges and burrs.

When using recommended cleaning agents in accordance with the manufacturer's installation and care instructions, there shall be no reduction in safety or function of the glazing material(s).

Note: For the purpose of this standard “sharp edges” are defined as edges which may inflict injury (broken skin) when in contact with persons.

#### **4.3 IMPACT RESISTANCE/SHATTER PROPERTIES**

##### **4.3.1 THERMALLY TOUGHENED SAFETY GLASS**

When tested in accordance with 5.1 (SANS 1263:Part 1) for all thermally toughened safety glasses the minimum particle count shall be 40 in a square of 50mm x 50mm.

##### **4.3.2 PLASTIC MATERIALS & LAMINATED SAFETY GLASS**

When tested in accordance with SANS 1263:Part 1, sheets shall not break or they shall break safely. Plastic sheets curved by hot bending are deemed to satisfy this requirement.

##### **4.3.3 SHELVES AND STABILIZING FINS**

###### **4.3.3.1 SHELVES**

Glass components shall be manufactured using thermally toughened safety glasses complying with SANS 1263:Part 1, having a maximum area of 0,08 square metres.

Glass roofs of steam showers or other full shower enclosures are to be constructed of laminated thermally toughened safety glass complying with SANS 1263:Part 1, unless the roofs are framed all round, in which case it is to be constructed of laminated safety glass complying with SANS 1263:Part 1

###### **4.3.3.2 FINS**

Structural fins shall be manufactured of thermally toughened safety glass complying with SANS 1263:Part 1. In the event of horizontal fins having an area in excess of 0,08 square metres these fins are to be manufactured of laminated thermally toughened safety glasses complying with SANS 1263:Part 1 unless approved by a Competent Person (Glazing) or Structural Engineer in terms of SANS 10400:Part N.

#### **4.4 DURABILITY**

##### **4.4.1 GENERAL**

Products conforming to the requirements of 4.2 and 4.3 and the following are deemed to be durable:

##### **4.4.2 CORROSION RESISTANCE**

All components shall consist of corrosion resistant materials or shall be corrosion-protected. All corrosion protection shall conform to the relevant test method specified in South African and International Standards.

##### **4.4.3 COATINGS**

###### **4.4.3.1 ANODISING**

All architectural anodising shall be in strict accordance with SANS 999. Specifications shall include colour, anodic film thickness ( $\mu$ ) and geographical location. The specific purchasing conditions contained in SANS 999 shall be deemed to be incorporated in this specification. A Certificate of Conformance is to be obtained, confirming that all anodising has been processed as aforementioned.

###### **4.4.3.2 POWDER COATING**

All architectural powder coating shall be in strict accordance with SANS 1796. Furthermore the powder applied shall be in strict accordance with SANS 1578. Specifications shall include colour, colour code, and if required, choice of powder manufacturer.

The specific purchasing conditions contained in SANS 1796 shall be deemed to be incorporated in this specification.

The powder manufacturer shall issue a powder guarantee of a minimum of 15 years. The specific conditions contained in this guarantee, shall form part of the powder coating “process” and may only be applied by an approved powder applicator.

All aluminium shall be pre-treated in accordance with SANS 1796 so as to ensure excellent adherence properties.

#### **4.4.3.3 ELECTROPLATING PROCESSES**

All metallic coatings (electroplating) shall be in strict accordance with:

- SANS 4526:1984 – Electroplated Coatings of Nickel for Engineering purposes
- SANS 6158:1984 – Electroplated Coatings of Chromium for Engineering purposes
- SANS 4525:1985 – Electroplated Coatings of Nickel plus Chromium on Plastics material

#### **4.4.4 FUNCTIONAL DURABILITY**

When tested in accordance with 5.2, shower enclosures shall not show any functional deterioration after 10000 closing and opening cycles.

#### **4.4.5 STRUCTURAL STABILITY**

When tested in accordance with 5.3, shower enclosures shall withstand an energy representing the impact of a human body on a large impact area without any functional deterioration which could result in injury to the user.

#### **4.4.6 WATER RETENTION**

When tested in accordance with 5.4 shower enclosures shall retain water. Assuming the surface installation is smooth only a few small drops of water on the outside of the shower enclosure are acceptable.

### **5. TEST METHODS**

#### **5.1 THERMALLY TOUGHENED GLASS**

To be tested in accordance with SANS 1263:Part 1.

#### **5.2 FUNCTIONAL DURABILITY**

5.2.1 Install the shower enclosure in accordance with the manufacturer’s installation instruction

5.2.2 Fix, at the opening edge of the door on a stable point, a means of automatically opening and closing the door. Ensure a steady velocity of  $(15 \pm 5)$  cycles/min can be maintained with the door being opened/closed over a distance of  $(70 \pm 10)$  % of the opening range of the door.

5.2.3 Subject the door to 10000 opening/closing cycles.

5.2.4 On completion of test check that the door still functions correctly.

NOTE: It is permissible to lubricate any guide or roll facilities in accordance with the manufacturer’s maintenance instructions.

#### **5.3 STABILITY**

5.3.1 Install the shower enclosure in accordance with the manufacturer’s installation instructions.

5.3.2 Carry out the test as described in SANS 1263:Part 1 with the impact body having a mass of 45  $(\pm 0,1)$  kg, falling inside the shower enclosure, with an energy as specified in Table 1.

The impact body shall drop on each panel and/or door on its geometric centre from the inside of the enclosure. If dimensions of shower enclosures do not allow the necessary drop height to reach the maximum energy given in Table 1, perform the test with the maximum drop height excursion angle of 65°. (Refer Figure 1)

5.3.3 Check for any functional deterioration which could result in injury to the user.

<b>Table 1 – Energy for stability test</b>		
<b>Distance to the opposite wall/panel mm</b>	<b>Energy to be applied, J</b>	<b>Falling height of impact body in mm</b>
≤ 600	63	130
≤ 700	94	190
≤ 800	125	250
> 800	135	280

## 5.4 WATER RETENTION

5.4.1 Install the shower enclosure in accordance with the manufacturer's installation instructions.

5.4.2 Test A and B shall be run consecutively using the test showerhead in accordance with Figure 2. and water of a temperature not exceeding 38°C.

5.4.3 Adjust the flow rate to (11 ± 1) l/min.

### TEST A

- (1) Spray for 1(one) minute across the width and height of all door(s)/panel(s) of the shower enclosure at 90° to their surface from a distance of 30cm using the test shower head. Restrict the spray to the area within 30cm below the top of the panel and 30cm above the bottom of the door(s)/panel(s).
- (2) Note the appearance of any leaks from the shower enclosure.

### TEST B

- (1) Install the shower enclosure in accordance with the manufacturer's installation instruction on a raised 50 mm x 50 mm wall or shower tray with a minimum bowl depth of 50 mm. If the shower enclosure is designed for a specific shower tray, that shower tray shall be used for testing.
- (2) Mount the test showerhead at a height of 1900 mm and set back at a distance of 300 mm from the centre of the door opening.
- (3) Direct the shower head vertically downwards and with the door closed spray the shower floor area for a period of 3 minutes (+1 -0).
- (4) Note the appearance of any leaks from the shower enclosure.

Figure 1 – Stability test arrangement

Dimensions in mm

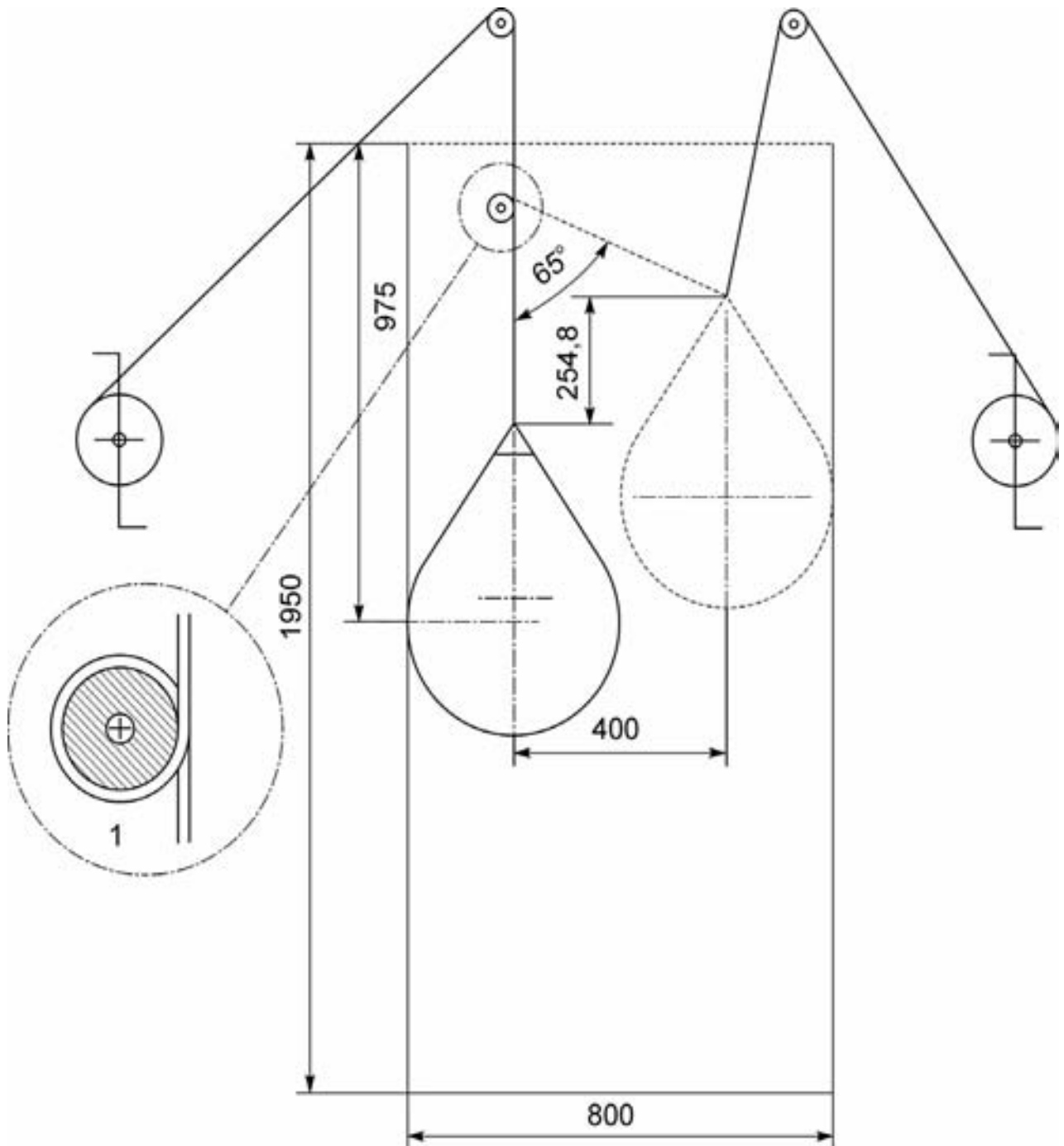

Legend:  
1. Wound Cable

**Figure 2 – Test showerhead**

Dimensions in mm



2. Six machine screws M 3,5 x 9,5mm long
3. Metal plate of thickness 1mm

**NOTES:**