



ASSOCIATION OF ARCHITECTURAL ALUMINIUM MANUFACTURERS OF SOUTH AFRICA

Trading as the AAAMSA Group

Registration #: 1974/00006/08

Association Incorporated under Section 21

Incorporating the Architectural Glass Industry

P O Box 7861
HALFWAY HOUSE
1685

1st floor, Block 4
Conference Park
234 Alexandra Avenue
Midrand

☎ (011) 805-5002/3
Fax: (011) 805-5033
E-mail: aaamsa@iafrica.com
Web site: www.aaamsa.co.za



South African Building Interior Systems Association

INTRODUCTION

The South African Building Interior Systems Association (SABISA), currently under the aegis of AAAMSA, promotes that part of the building industry which specializes in the interior finishing, altering and/or refurbishing of buildings. Membership constitutes manufacturers and suppliers of ceiling, partition and access flooring systems as well as subcontractors who sell and install these specialized systems.

This specification refers to the design, finishes, materials and installation of ceiling systems and will enable Architects, Engineers, Quantity Surveyors, Developers and other specifiers to select and specify the appropriate materials.

Having the installation done by subcontractors who are members of our Association will ensure that the installation meets with the minimum performance standards.

DISCLAIMER

Great care has been taken to ensure that the information provided here is correct. No responsibility will be accepted by AAAMSA for any errors and/or omissions which may have inadvertently occurred.

All information, recommendation or advice contained in these AAAMSA General Specifications and Selection Guides is given in good faith, to the best of AAAMSA's knowledge and based on procedures currently in effect.

Because actual use of AAAMSA General Specifications and Selection Guides by the user is beyond the control of AAAMSA, such use is within the exclusive responsibility of the user. AAAMSA cannot be held responsible for any loss incurred through incorrect or faulty use of this General Specification and Selection Guide.

This Guide may be reproduced in whole or in part, in any form or by any means, provided the reproduction or transmission acknowledges the origin and copyright date.

Copyright © AAAMSA 2007

TABLE OF CONTENTS

		Page
1.	Introduction	3
2.	Materials	4
3.	Recommended Specification and Bill Format	5
4.	Recommended Preambles	6
5.	Suspended Ceiling Tiles	7
6.	Suspended Ceiling Grid	7
7.	Perimeter Trims	8
8.	Sub-Grid Systems	9
9.	Suspension Components	10
10.	Ceilings and Fire	11
11.	Humidity	13
12.	Light Reflectance	13
13.	Baffles, Signs, Light fittings & Other Appendages	13
14.	Insulation	13
15.	Hold Down Clips	18
16.	Accuracy	19
17.	Safety	19
18.	Flush Plaster Ceiling Systems	20
19.	Grid Configurations	28
20.	Fixed Plaster Board Systems	28
Annex 1	Grid Configurations & Setting-out Guidelines	29
Annex 2	Fixing Materials	36
Annex 3	Typical Polystyrene Cornice Trims	39
Annex 4	Acoustic Insulation	41
	Matrix of SABISA Members	46-47

1. INTRODUCTION

The Association of South African Quantity Surveyors offers, inter alia, the following specification guidelines in their Standard System of Measuring Building Work 1999: Sixth Edition (Revised).

1.1 BILL OF QUANTITIES

Description in bills of quantities shall be complete and clear.

Unless otherwise stated the description of each item shall be deemed to include manufacturing, conveying and delivering, unloading, storing, unpacking, hoisting, setting, fitting and fixing in position, cutting, waste, patterns, templates, plant, temporary works, return of packing's, establishment charges, profit and other obligations arising out of the conditions of contract.

Unless prescribed, the method of execution of the work shall be at the discretion of the contractor.

1.2 CEILINGS

Ceilings shall be given in square metres, under headings separating nailed up and suspended ceilings, distinction being made between horizontal, sloping and vertical ceilings.

Bulkheads, fire barriers and the like shall be given in metres. Alternatively, when linear measurement is not practicable, bulkheads, fire barriers and the like may be given in detail in appropriate terms.

No deductions shall be made for openings, vents, etc., not exceeding 0.5m².

Plastering shall be included in the descriptions, no distinction being made for narrow widths.

Branding shall be included in the descriptions of nailed up ceilings. When branding is not to a regular pattern, it shall be given separately in metres.

Proprietary support systems for suspended ceilings shall be included in the descriptions of the ceilings. When the support system is not to a regular pattern it shall be given separately, in which case branding or bearers shall be given in metres and hangers in number. A general description of the supporting structure from which ceilings are suspended shall be given. Separate items shall be given for ceilings suspended less than 1m (one metre) below suspension level, and thereafter in successive stages of 1m (one metre).

Circular cutting shall be given in metres. Notches and holes shall be deemed to be included in the descriptions.

Openings for light fittings, mechanical diffusers etc., shall be given in number, as extra over ceilings and descriptions shall be deemed to include additional trimmers, hangers etc.

Cover strips, jointing strips etc., shall be included in the descriptions.

Cornices shall be given in metres and descriptions shall be deemed to include mitres and intersections.

Trapdoors shall be given in number, as extra over ceilings and descriptions shall be deemed to include trimmers.

Insulation materials such as fibreglass and mineral wool shall be given in square metres, stating whether in batts or rolls such as between roof timbers etc.

1.3 SABISA GUIDELINES FOR SUSPENDED CEILINGS INSTALLATION

Recognizing that problems and misunderstandings can occur between the contracting parties, the following provisions are recommended to prevent such problems arising.

1.3.1 CO-ORDINATION WITH MECHANICAL, ELECTRICAL AND OTHER TRADES

- All work of other trades above the ceiling shall be completed prior to the start of the ceilings. Where ductwork is so extensive as to make it impossible to install hangers in an area, the mechanical trades shall provide proper framing of adequate strength to support the ceiling from their framing, or extra payment for bridging shall be allowed to the ceiling contractor.

- It shall be the responsibility of all trades that incorporate any surface recessed, or units suspended, into the ceiling, to do these without distortion or damage to the ceiling.
- Mechanical, electrical and other trades shall make available to the ceiling contractor, prior to the start of the ceiling installation, adequate descriptive literature, samples and shop drawings of any item that is to be carried by or fixed to the ceiling.
- All windows and exterior doors shall be in place and glazed and the roof shall be watertight prior to the start of the ceiling installation.
- It is essential that the work of ALL wet trades shall be completed and adequately dried prior to the installation of ceiling products. This includes, inter alia, grinding of terrazzo floors, floor screed, brickwork and plastering.
- Installation of the ceiling materials should be made only when the temperature and humidity conditions approximate the interior conditions that will exist when the building is occupied. It should be noted that not all materials are equally sensitive to humidity and temperature. Reference should be made to the manufacturer of the specific product involved.

2. MATERIALS

Materials shall comply with the latest editions of the following specifications and requirements.

Material	Specification
Plasterboard	SANS 266
Plasterboard cove cornice	SANS 622
Softwood rendering and battens	SANS 653
Fibre-cement boards	SANS 803
Softwood studs for timber frames in buildings	SANS 1146
Materials for thermal insulation of buildings - Part I and II	SANS 1381
Materials for thermal insulation of buildings - Part IV	SANS 1381
Materials for thermal insulation of buildings - Part VI	SANS 1381
Expanded polystyrene thermal insulation boards	SANS 1508
Mineral fibre board	EN13964:2004

2.2 Ceilings etc.

The Architect shall agree to fixing points before any fixings are made. Hangers shall be suspended only from the main structure.

Descriptions of ceilings shall be deemed to include: hangers, suspension systems, ceiling panels and plaster finish where specified, as well as positioning of diffusers and light fittings, as required for setting out ceilings to layouts approved by the Architect and for modifications to standard suspension systems as necessary to work around any air-conditioning ducts or pipes or light fittings. (Sub-grid is optional).

2.3 COMPLIANCE WITH STANDARDS

“The Application of the National Building Regulations” SANS 10400 Part T: 2006 3rd Ed – Fire Protection states in paragraph 4.13 Ceilings. Quote:

4.13.1 In any building that is not a building classified as H3 and H4, combustible material shall not be used for any ceiling or suspended ceiling, or as a component thereof, except as provided for in (a) and (b) below

- a) An insulation, roof lining or ceiling tested in accordance with SANS 10177-5 and found to be combustible or used as part of a roof assembly, shall be acceptable if it complies with the requirements of SANS 428 when tested in accordance with SANS 10177-10.

provided that this requirement shall not apply where the thickness of such combustible material is less than 0,5 mm and such finish adheres fully to a non-combustible substrate.

- b) Air supply grilles or return air intake grilles of combustible material, where the sum of the area of all such grilles form not more than 5 % of the total area of such ceiling and the overall area of any individual grille is not more than 0,09 m², shall be permitted.

4.13.2 Where roof space is formed between a ceiling and a roof covering, such space shall be divided into areas of not more than 500 m² by means of non-combustible fire-stops with a stability and integrity rating of at least 20 min. The distance between such fire-stops shall be not more than 30m, provided that this requirement shall not apply where such roof space and the room below are protected by a fixed automatic fire-fighting system and an automatic smoke control system (or both).

Any such roof space used as an air-conditioning or artificial ventilation system plenum shall comply with the requirements contained in 4.43.6. Any under-roof insulation or insulation used in the roof space shall be considered as a ceiling and shall comply with all the relevant requirements.

3. RECOMMENDED SPECIFICATION AND BILL OF QUANTITIES FORMAT

Item	Description	Unit
3.1	Installation of the suspended ceiling shall be in accordance with the SABISA's General Specification for Suspended Ceilings, including flush plastered ceilings in horizontal applications.	
3.2	Description of the material specification, trade names where applicable and sub-grid.	
3.3	Description of phased installation (e.g. gridding before boarding)	
3.4	Description of Board type and finish e.g. 9.5mm Plasterboard: 600mm x 1200mm exposed grid mineral fibre 600mm x 300mm concealed grid mineral fibre etc.	Sq.m
3.5	Description of the supporting structure e.g. 25 Mpa concrete slabs 125 x 50 x 2.5mm steel purlins at 2 000mm centres 114 x 38mm timber joints at 900mm centres etc. <i>If steel purlins, state what sections i.e. cold rolled lip or hot rolled angles.</i>	
3.5.1	Fixings Test results to be obtained from suppliers/manufacturers. Aluminium pop rivets are not recommended for suspension systems.	
3.6	Finished floor to ceilings heights <ul style="list-style-type: none"> • Not exceeding 2.5m • Exceeding 2.5m but not exceeding 3.5m • Exceeding 3.5m but not exceeding 5.0m • Exceeding 5.0m 	Sq.m Sq.m Sq.m Sq.m
3.7	Suspension Drops (measured from purlins) <ul style="list-style-type: none"> • Not exceeding 1m • Exceeding 1m but not exceeding 2m • Exceeding 2min 1m increments to a maximum of 3.6m • Exceeding 3.6m , introduce sub-grid 	Sq.m Sq.m Sq.m Sq.m
3.8	Work in confined spaces <ul style="list-style-type: none"> • Not exceeding 5m² • Exceeding 5m² but not exceeding 12m² • Exceeding 12m² 	Sq.m Sq.m Sq.m

3.9	Perimeter Trims <ul style="list-style-type: none"> • Horizontal • Raking • Vertical • Short, i.e. less than 60mm • To columns, with full description of column girth and shape • Circular • Extra over for labour, for notching around architrave returns, into reveals, chamfering, packing out etc. 	 m m m Each Each m
3.10	Bulkheads Description shall include: <ul style="list-style-type: none"> • Girth, stating vertical and horizontal dimensions and/or radius • Depth of suspension from support to the highest horizontal face • Supporting structure • Abutments • Height above floor level • Concealed service • Provided sketches • Structural general design of the bulkhead remains the responsibility of the Architect or appointed Engineer. 	 m
3.11	Light fittings, air-conditioning etc. Support for these services is to be fully described with the openings measured in number; the sizes to be specific; stating whether the service is to be flush or recess mounted; and stating whether trims are required.	 Each
3.12	Temporary access for services <ul style="list-style-type: none"> • Provisional sum for materials • Provisional sum for labour 	 Value Value

4. RECOMMENDED PREAMBLES

4.1 The installation of the suspended ceiling shall be strictly in accordance with the latest specification and co-ordinated ceiling layout drawings. To ensure a quality installation with satisfactory performance life, it is strongly recommended that members of the South African Building Interior Systems Association (SABISA) are employed. Certificates of compliance as issued by the contractor may provide further proof of competency. SABISA monitors its members for the use of correct installation techniques, the use of quality materials, and the application of quality workmanship.

4.2 Mechanical, electrical, air-conditioning, plumbing and other services (e.g. sprinklers) shall be installed prior to the start of any ceiling installation. and the respective trades shall make available to the ceiling contractor, prior to the start of the ceiling installation, adequate descriptive literature, samples and shop drawings of any item that is to be carried by or fixed to the ceiling. (Refer also Section 1.3).

4.3 The following to be enforced:

4.3.1 All wet trades shall be completed and adequately dry prior to the installation of ceiling products. This includes grinding of terrazzo floors, floor screed, brickwork and plastering of walls.

4.3.2 All work of other trades above the ceiling shall be completed prior to the start of the ceiling installation.

Note! Where ductwork is so extensive as to make it impossible to install hangers in an area, the mechanical trades shall provide proper framing of adequate strength to support the ceiling from their framing. Under no circumstances is the ceiling grid to be suspended from any of the service installations.

4.3.3 All windows and exterior doors shall be in place and fully glazed and the roof and/or intermediate floor slabs shall be watertight prior to the start of the ceiling installation.

4.4 Mineral fibre and other similar ceiling panels are to be installed only in areas where temperatures and humidity conditions approximate the interior conditions anticipated during occupation.

Note! Air-conditioning should be fully operational prior the installation of ceiling tiles. A minimum RH of 60% should be maintained before installing ceiling panels.

5. SUSPENDED CEILING TILES

Ceiling tiles are manufactured from a wide variety of materials, including composite materials. Typically, suspended ceilings tiles will be manufactured from:

Substrate	Approximate Mass (kg/m ²)	Thickness
Cellular (EPS, PIU etc.)	Subject to enquiry	Subject to enquiry
Fibre-cement	5.54 or 8.32	4 or 6mm
Fibre-cement Vinyl covered	5.74 or 8.52	4 or 6mm
Fibre-cement with polystyrene backing	5.82 or 8.60	27 or 29mm
Plasterboards Vinyl covered	6.6 or 10.0	9.0mm or 12.5mm
Plasterboards Vinyl covered	8.78 or 10.0	12.0mm or 12.5mm
Mineral Fibre	4.5	15.0mm
Vinyl Glass Wool	1.1	25.0mm and 40.0mm
Pressed Metal/Pan Metal	Consult Manufacturer	Subject to enquiry

Tile sizes

Tiles vary in size but sizes are determined by the tolerance of the ceiling grid. Typical sizes are:

Nominal size	Actual size
1200 x 600mm -	1195 x 595mm
600 x 600mm -	595 x 595mm
1500 x 500mm -	1495 x 495mm
500 x 500mm -	495 x 495mm

Other sizes require discussion with the ceiling tile and grid manufacturers. Imperial sizes are no longer used as a standard in South Africa nor in most other African countries.

The manufacturer's recommendations regarding the installation and maintenance of mineral fibre and other similar ceiling panels must be adhered to at all times. Alternative edge details and grid systems may be available; contact the manufacturer for further information.

TILE EDGE DETAIL (TYPICAL)

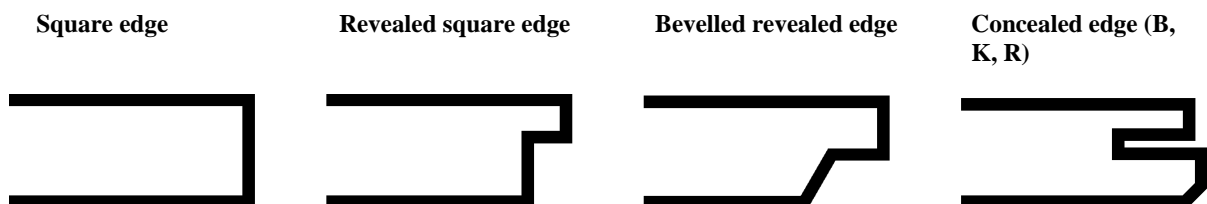

6. SUSPENDED CEILING GRID

Ceiling Grid Systems are manufactured from cold rolled, formed, galvanized mild steel and are faced with capping which is usually coloured. Capping may be manufactured of aluminium or steel.

The standard face widths of the grid system are 15mm, 25mm and 35mm. Each width has its own preferred application, but no real construction criteria exist for their respective usage. i.e. a 15mm grid system will accept any lay in tile size; a 25mm and a 35mm grid will do the same. However, some revealed edged tiles will only fit into the narrow grid (15mm). We therefore recommend that, when specifying revealed edged tiles, the correct grid for the particular tile should be checked.

Suggested heading for drawings shown here:

STANDARD FACE DIMENSIONS (mm)

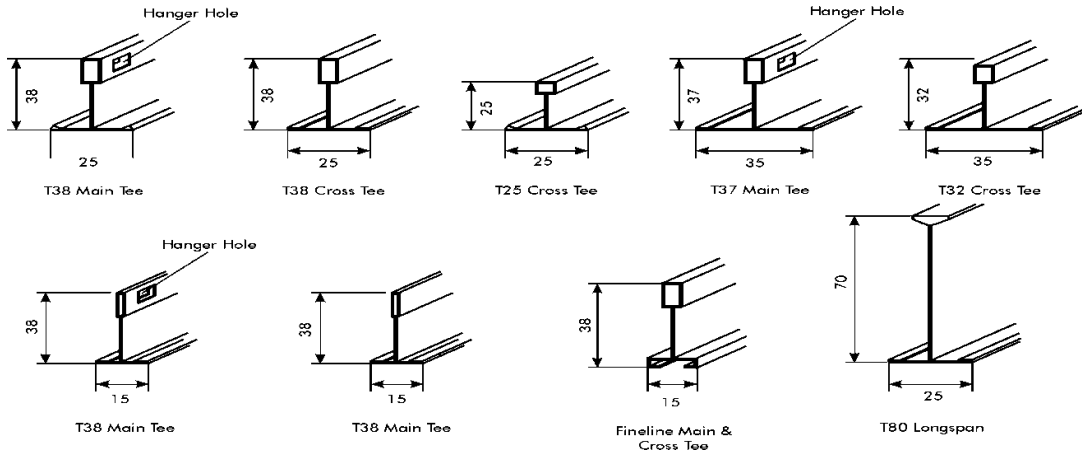

The wide grid (35mm) is recommended in areas where additional support for the ceiling tile is required, e.g. under outside overhangs where the nature of the tile makes accurate sizing of the tile difficult to control.

Manufacturers may be contacted for a detailed installation process of suspended ceiling grid systems. Manufacturers' test certificates may be requested for performance of grids. Grids must conform to BS 8290.

Maximum spans of suspension on main tee

Standard tees shall be supported at a maximum of 1.2m centres. For greater spans, contact the manufacturer for details.

Junction between Perimeter Trims and Ceiling Grid

For cross tees greater than 600mm, an additional suspension point should be added. Cross Tee's exceeding 400mm must be suspended ± 100 mm from the perimeter edge. When using a lightweight tile e.g. Mineral fibre, the above is not required.

Sloped, Angled, Specialized and Other Ceiling levels

These ceilings require specialist fixings. Contact the manufacturers for detailed information.

Perimeter hangers

The first suspension support on the main tee shall be not more than 400mm from wall.

7. PERIMETER TRIMS

Perimeter trims – Standard suspended ceilings

Perimeter trims for suspended ceilings may be L-shaped or shadow-line type (stepped) – refer Typical Cornice Trims.

Perimeter trims – Flush plaster suspended ceilings

Galvanised angles are L-shaped, or a shadow-line type may be used to create a shadow-line which hides building imperfections – refer Typical Galvanised Angles.

The perimeter trims are measured as a separate item in bills of quantities.

Flush plaster suspended ceilings

To minimise the effects / risk of cracking on plastered ceilings, it is advisable to allow the grid to "float" i.e. don't fix the components to the perimeter.

Where cross Tee's exceed 400mm from the perimeter wall, an additional suspension hanger (galvanized angle) must be fitted; this will prevent the board lifting when being plastered.

Exposed suspended ceilings

Main tees are fixed to the wall with angle cleats which are attached to the tee web and are secured through the wall angle or perimeter trim to the wall. This is to stabilize and align the ceiling as well as to avoid displacement of the tees during erection. Tee's are fixed after the first row of cross tee's have been clipped into the main tee, this enables erection from a fixed reference point.

TYPICAL CORNICE TRIMS (mm)

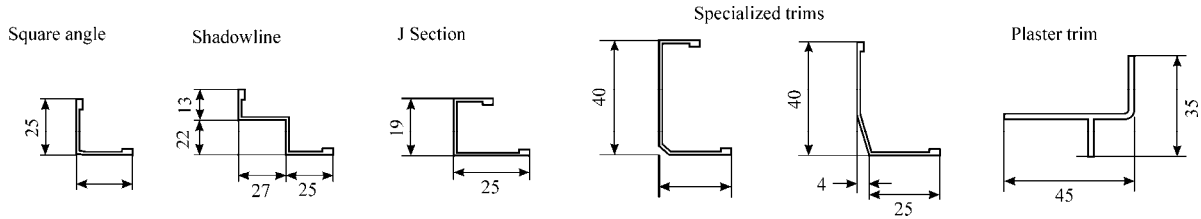

TYPICAL GALVANIZED ANGLES (mm)

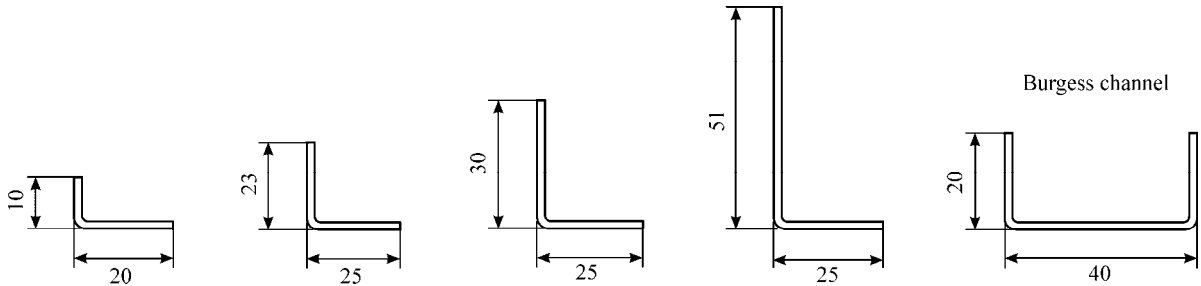

8. SUB-GRID SYSTEMS

Sub-grid construction is required when:

- Hanger is out of plumb by more than 25mm for 150mm depth and ceiling is suspended by more than 3.0m.
- The ceiling plumb suspension height exceeds 3.0m.

BURGESS CHANNEL (Sub-Grid)(mm)



9. SUSPENSION COMPONENTS

Suspension components will consist of a number of different items which when combined/joined or used in conjunction with each other will create an effective suspension system. The weakest component/joint in the system will determine the breaking point of the suspension system. This information is available from the various manufacturers.

Often a substitute product will be used to suspend a ceiling grid system. The onus is on the specifier to ensure that components that comply with minimum standards are used. Guidance can be obtained from the grid manufacturers.

Typical standard/approved components are:

- Pre-straightened galvanized hanger wire 2.5mm or thicker
- Galvanised 19mm wide x 0.8mm thick steel hanger strap
- 4mm suspension rods with adjustable spring clips
- Galvanised angle 20mm x 20mm x 0.6/0.8mm (Minimum)
- Galvanised angle 25mm x 25mm x 0.6/0.8mm (Minimum)
- Galvanised angle 50mm x 25mm x 0.6/0.8mm (Minimum)

TYPICAL SUSPENSION COMPONENTS

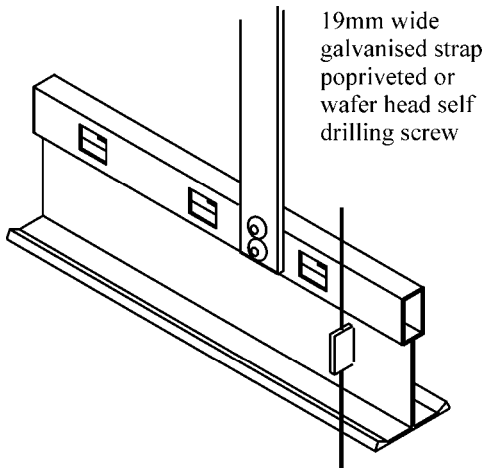

19mm Strap Suspension

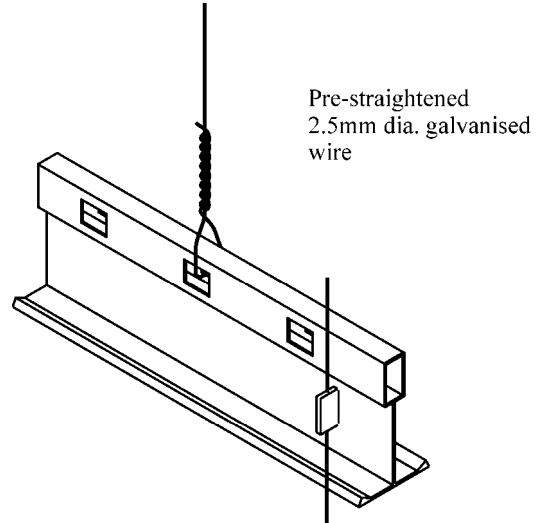

2.5mm Wire Suspension

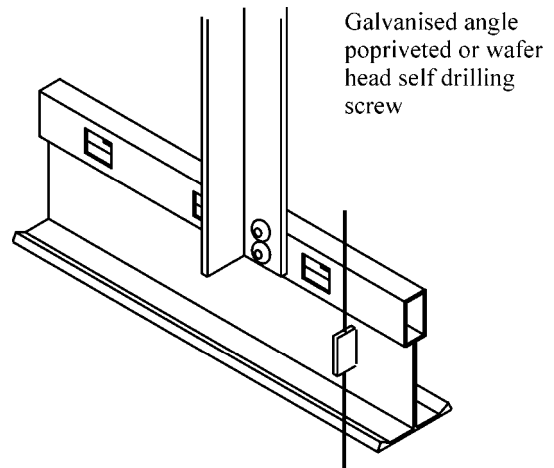
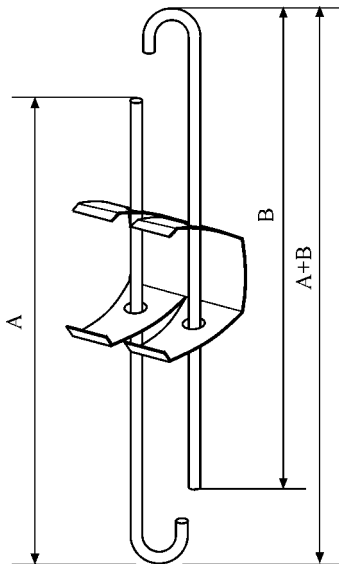

Angle Suspension

Fixings/Fasteners used are:

- Pop rivets 3.2mm steel x 2
- Wafer Head tek screws 4.5mm x 13
- Shots & pins
- Nylon plug & nails
- Nail plug & anchors
- Angle cleats 20mm x 30mm
- Hold down clips / wires

} Consult manufacturer of fixings and fasteners for the correct selection.

To ensure a higher safety factor for suspended ceilings it is recommended that the number of fixings is doubled. The manufacturer of the fixing component is responsible for the carrying, shearing and/or any other loads that their fixing can sustain.

Ceiling grid manufacturers will offer construction guidelines but the ultimate responsibility rests with the specifier to ensure that the correct fixing method is used for each particular situation. It is also important to note that the building structure must be of such a nature that it is able to sustain the load of the ceiling that has been specified, with the permissible (§) wire suspension and suspension intervals and/or deviations from the vertical position.

- (§) - Hanger spacing to be a maximum of 1.2m on the main tee
- Hanger should not be out of plumb by more than 25mm for 150mm depth.

10. CEILINGS AND FIRE

Combustibility

Materials used for the construction of ceilings are to be classified in accordance with SANS 428:2006 Ed 1 entitled “Fire performance classification of thermal insulated building envelope systems” in November 2006.

The symbolic classification will inform the professional and /or consumer about the limitations and usage of a product. This information will appear on the product, technical data sheet as well as the packaging.

B.1 Combustibility and surface fire properties

The symbols given in tables B. and B.2 shall be used to indicate combustibility and surface fire properties.

Table B.1 – Symbolic classification of non-combustible materials

1		2		3		4	
				Surface fire properties			
Small-scale application <small>a</small>	Large-scale application <small>b</small>			Behaviour of material		Classification	
Flame height from fire source mm							
≤ 2 000	≤ 4 000			No flame spread		A1	
≤ 3 000	≤ 6 000			Low flame spread (no flaming droplets or burning brand)		A2	
≤ 3 000	≤ 6 000			Low flame spread (with flaming droplets or burning brand)		A3	
≤ 4 000	≤ 8 000			Average flame spread (no flaming droplets or burning brand)		A4	
≤ 4 000	≤ 8 000			Average flame spread (with flaming droplets or burning brand)		A5	
> 4 000	> 8 000			Rapid fire spread		A6	
<small>^a When determined in accordance with SANS 10177-10.</small>							
<small>^b When determined in accordance with SANS 10177-11.</small>							

Table B.2 – Symbolic classification of combustible materials

1		2		3		4	
				Surface fire properties			
Small-scale application <small>a</small>	Large-scale application <small>b</small>			Behaviour of material		Classification	
Flame height from fire source mm							
≤ 2 000	≤ 4 000			No flame spread		B1	
≤ 3 000	≤ 6 000			Low flame spread (no flaming droplets or burning brand)		B2	
≤ 3 000	≤ 6 000			Low flame spread (with flaming droplets or burning brand)		B3	
≤ 4 000	≤ 8 000			Average flame spread (no flaming droplets or burning brand)		B4	
≤ 4 000	≤ 8 000			Average flame spread (with flaming droplets or burning brand)		B5	
> 4 000	> 8 000			Rapid fire spread		B6	
<small>^a When determined in accordance with SANS 10177-10.</small>							
<small>^b When determined in accordance with SANS 10177-11.</small>							

B.2 Use of materials

The symbols given in table B.3 shall be used to indicate the designated use of materials (see also SANS 10400-A for occupancy classifications).

Table B.3 – Limitations on the use of materials

1	2
Use identification	Occupancy description (use or limitation)
A1	No limitation
B1 and 2	All occupancies, except for the proviso listed in SANS 10400-T
3	All single-storey and double-storey buildings, except A1, C1, C2, E1, E2, E3, H1 and H2
4	All single-storey buildings, except A1, C1, C2, D1, E1, E2, E3, H1 and H2
5	All single-storey buildings, except A1, A2, A3, C1, C2, D1, E1, E2, E3, F1, F3, G1, H1, H2, J1 and J4
6	Not acceptable for any application

B.3 Application of materials

The symbols given in table B.4 shall be used to indicate the designated application of materials.

Table B.4 – Symbolic application identification of materials

1	2
Application identification	Description of permissible application
H	Horizontal (under-roof) only
V	Vertical (side cladding)
HV	Horizontal and vertical

B.4 Example of product identification

A product shall be identified as follows:

Combustibility / surface fire properties / use / application

For example: **B/B1/2/HV**

FIRE RATED

“Fire – resistance ratings” is the term used to indicate the performance of a constructed ceiling system. It should be noted that no one component is fire rated it is the system that is when tested in accordance with SABS 10177:Part II.

Specified samples of these systems are tested and then certified in their entirety. This fire rating is expressed in time e.g. F30 minutes/ ½ hour; F60 minutes/ 1 hour; F90 minutes/ 1½ hour; F120 minutes/ 2 hour. Fire rating of above 2 hours is rare, manufacturers will be able to assist when longer fire rated times are required.

FIRE RATED CEILING SYSTEM

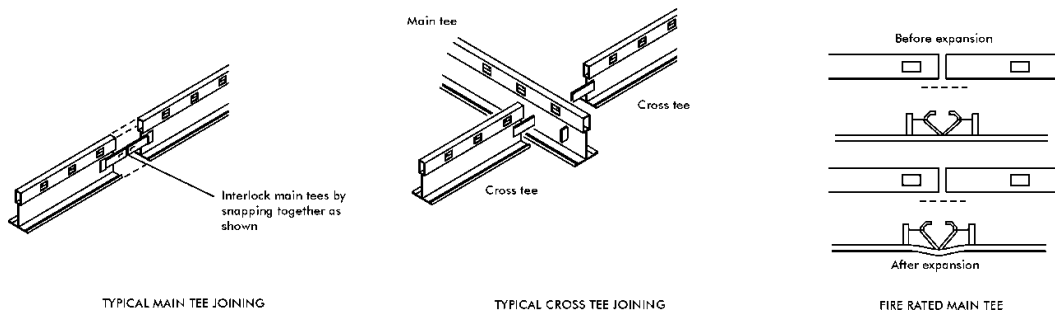

Light fittings and other items

Light fittings, speakers, air grilles etc. all influence the fire rating of ceilings. Where the fire rating is the important factor, it is advisable to request the assistance of the ceiling tile and grid manufacturer.

11. HUMIDITY

Modern ceiling panels are all designed and composed to improve sag resistance. Testing of the ceiling panels typically entails samples being placed into climate chambers where adverse conditions are simulated for a period of time. The typical time period is usually up to 48 hours with readings taken at 24 and 48 hours. The temperature and humidity may vary according to request. In South Africa the tests are taken at 95% humidity, at 32° Celsius, over a 48-hour period. The international classification for sag (ASTM C473) classifies any product with sag of less than 3.0mm after 48 hours under these conditions, as a high-performance product.

Mineral fibre ceiling tiles are manufactured to different humidity specifications, which may range from 70% up to 95% and, in exceptional cases, to 99%. Mineral fibre tiles require that the humidity in buildings must be stabilized before these types of tiles are inserted into the ceiling grid. It is important to note that this will affect the guarantee/warranty of these ceiling tiles. Adequate ventilation and/or insulation must be provided to prevent condensation in the plenum.

12. LIGHT REFLECTANCE

Light reflectance is the ability of a surface to reflect light back into a space. The light reflectance of a variety of ceiling tiles measured in South Africa indicated a reflectance range from 0.8 to 0.92, with the mean being 0.84 from a sample group of 30 tiles. A reflectance of 0.85 is considered to be high.

13. BAFFLES, SIGNS, LIGHT FITTINGS AND APPENDAGES

Baffles are used to assist with acoustic control in open plan offices. Signs are used to offer information. Appendages may include a range of items, such as promotional items suspended from ceilings in retail stores for a limited period.

Important points to note are:

- Baffle/sign weights should not place undue stress on the ceiling grid. Where the weight of the baffle/sign exceeds 10kg, extra suspension support must be added to the ceiling grid.
- Suspension of the baffle/sign should always be from the main tee.
- Suspension should not be more than 300mm from a suspension point/wire used to suspend the grid system from which the baffle/sign is suspended.
- Additional suspension is required where recessed types of luminaires are suspended from the ceiling grid.
- Where light fittings have a known mass of 10kg or more, additional suspension should be used on the grid.
Any unsupported weight that causes the grid to deflect more than 1/360 of the span is not allowed and should be suspended separately.

14. INSULATION

Insulation can improve the acoustic and thermal performance of the ceiling. It is important to distinguish between the two aspects of insulation: Thermal and Acoustic. Please make sure the correct insulation is used for the specified purpose. Consult the manufacturer.

Where additional thermal or acoustic performance is required, please consult the manufacturer of the insulation material for further information.

14.1 THERMAL INSULATION

Benefits

Insulation is the cost effective way to improve the energy efficiency of a home or a building. Insulation of the building envelope helps keep heat in during the winter and out in summer to improve comfort and save energy. Insulation can add additional benefits such as acoustics and waterproofing. Effective draught proofing and ventilation is important at design state.

How insulation works

An un-insulated home is subject to considerable winter heat losses and summer heat gains.

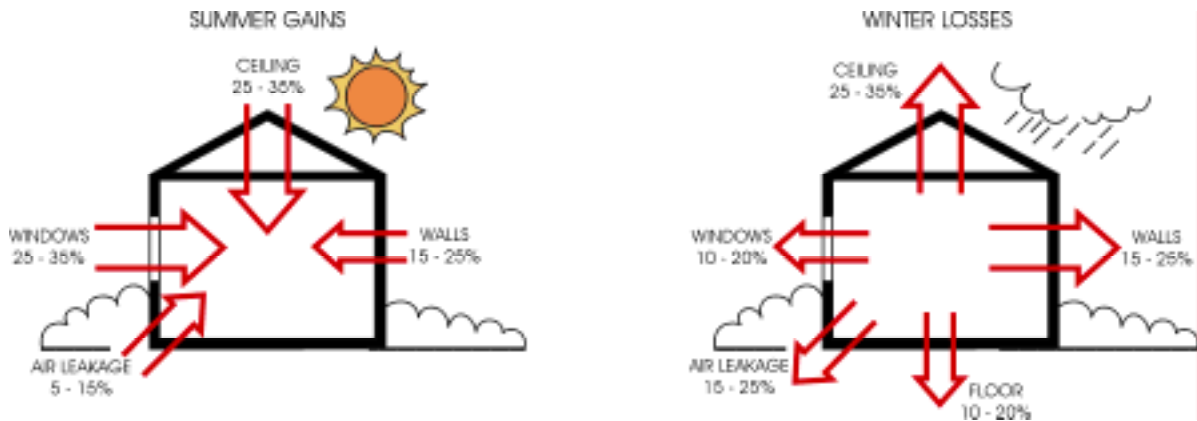

The term “insulation” refers to materials which provide substantial resistance to heat flow. When these materials are installed in the ceiling, walls, and floors of a building, heat flow into out of the building is reduced, and the need for heating and cooling is minimised.

Principles of insulation

Resistance to heat flow is achieved by the use of either bulk insulation or reflective insulation, or a combination of both, composites, which work in different ways.

Understanding thermal mass

Thermal mass is a term used to describe the ability of building materials to store heat (thermal storage capacity). The basic characteristic of materials with thermal mass is their ability to absorb heat, store it, and at a later time release it.

Adding thermal mass within the insulated building envelope helps in stabilising the extremes in temperature variances experienced inside the building. This will result in the average internal temperature being more moderate year-round and the building more comfortable to live and work in. It also offers the additional benefit of reducing noise, dust and moisture, depending on material selection.

HOW INSULATION PRFORMANCE IS MEASURED

Understanding thermal values

The thermal performance of all components except windows and doors is expressed in terms of R-value; for windows and doors, performance is expressed in terms of U-value.

R-value (thermal resistance)

Insulation materials are rated for their performance in restricting heat transfer. This is expressed as the R-value, also known as thermal resistance. The R-value is a guide to its performance as an insulator – the higher the R-value, the better insulation (i.e., resistance to heat flow) it provides. Reflective foil membranes (RFL), are rated in combination with air spaces.

R-values are expressed using the metric units m^2K/W , where:

- m^2 refers to one metre square of a material at a specified or given thickness;
- K refers to a one degree temperature difference (Kelvin or Celsius) through the material;
- W refers to the amount of heat flow through the material in watts.

Products which have the same R-value will provide exactly the same insulating effect as each other, provided they are correctly installed.

U-value (thermal transmittance)

Sometimes insulation is rated in terms of its U-value, rather than its R-value. The U-value measures the transfer of heat through a material, combination of materials or materials in combination with air spaces or a building element (thermal transmittance), whereas the R-value measures the resistance to heat transfer. U-values are often used in technical literature, especially to indicate the thermal properties of glass and to calculate heat losses and gains.

The U-value is expressed using the metric units (W/m^2) where:

- W refers to the amount of heat transmitted through the material in watts;
- m^2 refers to one metre squared of a material at a specified thickness; and
- K or “degree Kelvin” refers to each $^{\circ}C$ temperature difference through the material

The U-value is the reciprocal of the R-value, $R=1/U$ or $U=1/R$. For example, with an R-value of 2.0, the U-value is $1/2$ or 0.5. A smaller U-value results in lower heat flow, and therefore less heat loss. Higher U-values mean greater heat loss. The U-value is the reciprocal of the R-value, which is the resistance to heat flow ($U\text{-value} = 1/R\text{-value}$).

Overall/Total R-value

The Overall/Total R-value is the total resistance of a building element. It takes into account the total resistance provided by a combination/building materials used in a floor, wall, ceiling or roof, also air spaces, thermal bridging, insulation materials and air surface co-efficiency adjacent to solid materials. Each of these components has its own inherent R-value, the sum of which provides the Total R-value or U-value at given temperatures.

CLIMATIC ZONES

Design for comfort and energy efficiency is influenced by climatic conditions. To achieve the best results, building design and construction materials should be appropriate to the climate of a region. While each of the six climate zones have different heating and cooling needs, the same principles of energy efficient design apply, with their application varying slightly, e.g. different levels of insulation or thermal mass or variations in window sizes, orientation and shading.

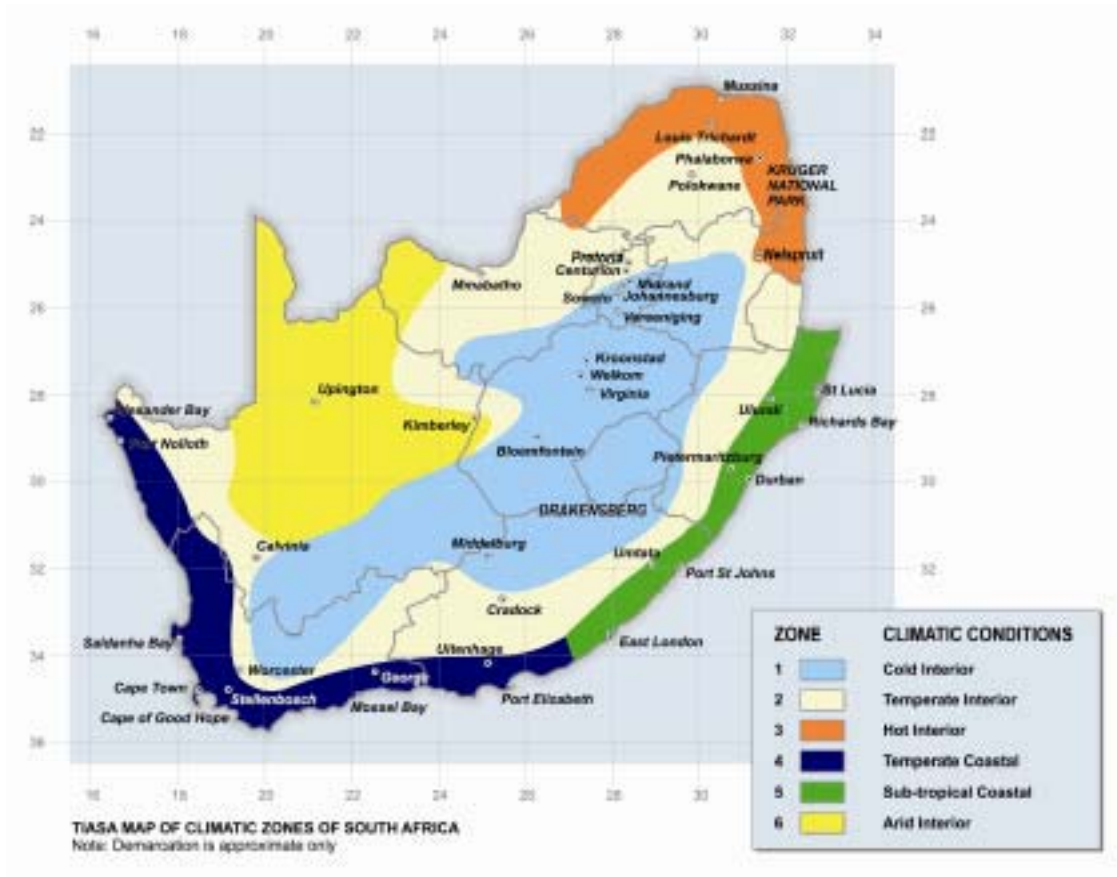

Recommended Insulation levels

A national framework is in the process of being developed for energy ratings in houses and buildings which will address insulation as one of several components. Government regulations will be introduced specifying minimum insulation levels for all new homes and buildings built in South Africa. Small alterations or renovations to existing buildings requiring a building permit may also have to comply with the regulations.

The following proposed deemed-to-satisfy rules are to be applied in the event that mechanical/electrical Engineers are not employed by the building owner at the design state of the building.

Deemed-to-satisfy rule for energy efficiency in roof and ceiling construction

Climate zones	1	2	3	4	5	6
Minimum required Total R-Value (for roof solar absorptance of more than 0.55) m ² K/W	3.7	3.2	2.7	3.7	2.7	3.5

Recommended levels of insulation to achieve deemed-to-satisfy rule for energy efficiency in typical roof and ceiling construction

Climate zones			1	2	3	4	5	6
Minimum required Total R-Value (for roof solar absorptance of more than 0.55) m ² K/W			3.7	3.2	2.7	3.7	2.7	3.5
Direction of heat flow			Upwards	Upwards	Downwards and Upwards	Upwards	Downwards	Upwards
Total R-Value of roof and ceiling materials (Roof covering & Plasterboard only)			0.34	0.34	0.34	0.34	0.39	0.34
Minimum added R-Value of insulation			3.36	2.86	2.36	3.36	2.31	3.16
Insulation Product	Density Kg/m ³	Thermal Conductivity W/mK	Recommended min thickness (mm) of insulation product					
Cellulose Fibre Loose-Fill	27.5	0.040	140	120	95	140	95	130
Flexible Fibre Glass Blanket	10-18	0.040	140	120	100	140	100	130
Flexible Polyester Blanket	11.5	0.046	160	140	120	160	120	150
Flexible Reflective Foil * See foot note	*	*	*	*	*	*	*	*
Flexible Mineral/Rockwool	60-120	0.033	115	100	80	115	80	115
Flexible Ceramic Fibre	84	0.033	115	100	80	115	80	115
Rigid Expanded Polystyrene (EPS) SD	20	**0.035	120	100	90	120	90	115
Rigid Extruded Polystyrene (XPS)	32	**0.028	100	85	70	100	70	95
Rigid Fibre Glass Board	47.5	0.033	115	100	80	115	80	115
Rigid Polyurethane Board	32	**0.025	90	70	60	90	60	80
Rigid Polyisocyanurate Board	32	**0.025	90	70	60	90	60	80

Note:

(*)For information on deemed-to-satisfy rule options on Reflective Foil Laminates contact manufacturers.

(**)Thermal Conductivity used for calculation of recommended thicknesses of insulation materials as per TASA Protocol for Routine Testing in naturally ventilated buildings. Thermal efficiencies are dependant on materials thickness, density, age, operating temperature and moisture. Thicknesses rounded-up to nearest production standard. This is a guideline for general design purposes. For critical design purposes, contact manufacturers for actual R-values (Thermal Resistance m²K/W), valid test reports and refer ISO 10456.

(***)Actual R-values for roof construction systems are established through testing in accordance with ASTM and the SAFIERA Rotatable Guarded Hot box. Specifiers are encouraged to obtain these test results from the thermal insulation manufacturers.

Important notice: The aforementioned deemed-to-satisfy recommended levels of insulation can be achieved by the use of reflective foils, bulk insulation or rigid board insulation or in combination with one another. Maximum efficiency may be achieved at reduced thicknesses taking the aforementioned into account.

Reflective foil laminates

Typical roof and ceiling options

Emittance of added reflective insulation	Direction of heat flow	R-Value added by reflective insulation inclusive of 15mm air gap					
		Pitched roof (> 10 °) with horizontal ceiling		Flat skillion or pitched roof (< 10 °) with horizontal ceiling	Pitched roof with cathedral ceilings		
		Natural ventilated roof space	Non-ventilated roof space		22 ° pitch	30 ° pitch	45 ° pitch
0.2 outer 0.05 inner	Downwards	1.21	1.08	1.28	0.96	0.86	0.66
0.2 outer 0.05 inner	Upwards	0.59	0.75	0.68	0.72	0.74	0.77
0.9 outer 0.05 inner	Downwards	1.01	0.92	1.06	0.74	0.64	0.44
0.9 outer 0.05 inner	Upwards	0.40	0.55	0.49	0.51	0.52	0.53

* Reflective foil insulation values inclusive of 15mm air gap.
Reflective insulation must work in conjunction with air gap to be effective.

Example of bulk insulation used in conjunction with a reflective foil insulation

Direction of heat flow	No Insulation		Foil Only		Foil/Blanket	
	Summer ↓	Winter ↑	Summer ↓	Winter ↑	Summer ↓	Winter ↑
O/s Air surf Co-ef	0.05	0.05	0.05	0.05	0.05	0.05
Metal roof sheet e 0.90	0.00	0.00	0.00	0.00	0.00	0.00
Min 50mm Air gap e.90	-	-	0.192	0.143	0.192	0.143
RFL Membrane e 0.90=0.05	-	-	-	-	-	-
Air space to ceil 100mm>+	0.19	0.14	1.47	0.385	1.47	0.385
105mm x 12kg F/g Blanket	-	-	-	-	2.63	2.63
Ceiling board 9mm Gypsum	0.05	0.05	0.05	0.05	0.05	0.05
Inside Air Surf Co-ef e.090	0.147	0.091	0.147	0.091	0.147	0.091
Direction of heat flow	Summer ↓	Winter ↑	Summer ↓	Winter ↑	Summer ↓	Winter ↑
Total "R" – Resistance m ² K/W	0.437	0.331	1.91	0.72	4.54	3.349
Total "U" Thermal Transmittance W/m ² K	2.29	3.02	0.52	1.39	0.22	0.30

Metal sheet clad pitched 45°< roof with flat gypsum ceiling

Assumptions:

- Roof colour red or green sheet aged
- On 50mm thick x 75mm pine timber purlins
- Ceiling flat 9mm Gypsum Plaster board fixed to rafter (tie beam) on 38mm x 38mm Timber Pine batten
- Natural ventilated attic space not sealed
- Upper surface of foil grey (dust covered)
- Foil layed as sarking slightly ditched between the trusses fixed under purlins

Deemed-to-Satisfy rule for energy efficient roof lights

Table 2 – Roof lights – thermal performance of transparent and translucent elements

Roof light shaft index (see Note 1)	Total area of roof lights serving the room or space as a percentage of the floor area of the room or space		
	More than 1.5% and up to 3%	More than 3% and up to 5%	More than 5% and up to 10%
Less than 0.5	SHGC of not more than 0.75 and a Total U-value of not more than 6.5	SHGC of not more than 0.50 and a Total U-value of not more than 5.0	SHGC of not more than 0.25 and a Total U-value of not more than 2.5
0.5 to less than 1.0	Total U-value of not more than 6.5	SHGC of not more than 0.70 and a Total U-value of not more than 5.0	SHGC of not more than 0.35 and a Total U-value of not more than 2.5
1.0 to less than 2.5	Total U-value of not more than 6.5	SHGC of not more than 0.45 and a Total U-value of not more than 5.0	SHGC of not more than 0.45 and a Total U-value of not more than 2.5
2.5 to above	Total U-value of not more than 6.5	Total U-value of not more than 5.0	Total U-value of not more than 2.5

Notes:

1. The roof light shaft index is determined by measuring the distance from the centre of the shaft at the roof to the centre of the shaft at the ceiling level and dividing it by the average internal dimension of the shaft opening at the ceiling level (or the diameter for a circular shaft) in the same units of measurement.
2. The total area of roof lights in the combined area for all roof lights serving the room or space.
3. The area of a roof light in is the area of the roof opening that allows light to enter the building.
4. The thermal performance of an imperforate ceiling diffuser may be included in the Total R-value of a roof light.

Deemed-to-satisfy rule for energy efficiency in building sealing

Construction of Roofs, Walls and Floors

Roofs, external walls, external floors and any opening such as windows or doors in the external fabric must be constructed to minimise air leakage. It can be sealed by caulking, skirting, architraves, cornices etc.

External Windows and Doors

Permissible air leakage through specimen shall be 2L/sq.m with a pressure difference of 75Pa. For swing doors and revolving doors the permissible air leakage shall be 5L/sq.m with a pressure difference of 75Pa.

14.2 ACOUSTIC INSULATION

Sound absorption

It is the loss of sound energy and is often created by introducing acoustically absorbing products into a room which is considered as too “reflective or reverberant” for its intended use. Refer Annex 4 for further information.

15. HOLD DOWN CLIPS (at the discretion of the Specifier/Architect)

- Hold down clips are used to assist with the acoustic performance of ceiling tiles, i.e. by holding the tiles in place.
- Hold down clips assist by keeping the tiles in place where excess updraft is experienced in a building.

TYPICAL HOLD DOWN FITTINGS

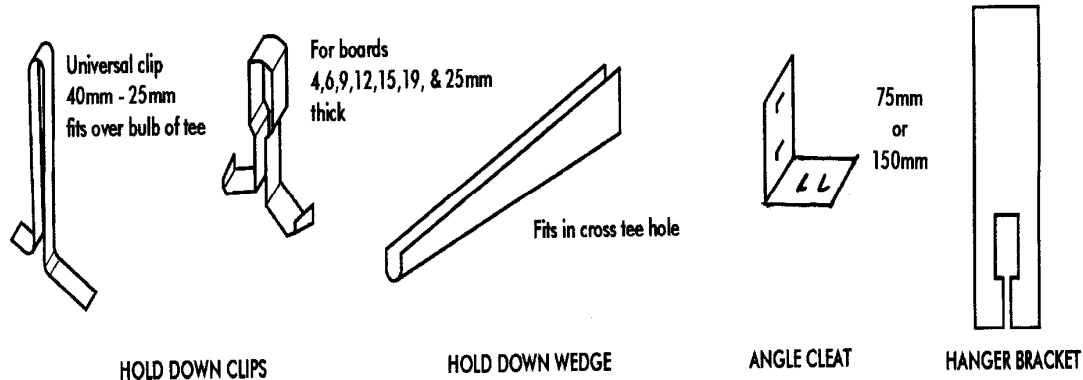

16. ACCURACY

As absolute accuracy exists only in theory, tolerable degrees of inaccuracy have to be accepted in practice.

SANS 10155-1980 – Code of Practice for Accuracy in Buildings specifies permissible deviations in elements or components above foundations in its Table 4 as follows:

DESCRIPTION	Permissible deviation in IN mm - Grade II
Position on plan of any edge or surface measured from the nearest grid line or agreed centre-line	±15
Linear (other than cross-section) dimensions	±20
Cross-Section dimensions	-5 + 15
Level (deviation from design level with reference to the nearest transferred datum (TD) of the upper or lower surface, as may be specified, of any slab or other element or component)	-15 + 5
Vertical, per metre of height, subject to a maximum of	5 50
Out of squareness of a corner or of an opening of an element such as a column for short side of length	
a) up to and including 0.5m	±5
b) over 0.5m and up to and including 2m	±15
c) over 2m and up to and including 4m	±20
Exposed surface	
a) Flatness of plane surface	5
b) Abrupt changes in a continuous surface	5
Exposed surface to be plastered	
a) Flatness of plane surface	10
b) Abrupt changes in a continuous surface	5

17. SAFETY

Ceiling systems are not designed to carry excess or additional structural loads. It is therefore recommended that catwalks are installed where access is required to other services above the ceiling, and that personnel walkways are installed above the installed ceiling. It is recommended that appropriate suspension is used to support these loads independently of the ceiling system. This applies also to bulkheads, signs and other appendages. Any load that is installed below the ceiling should be independently supported.

18. FLUSH PLASTER CEILING SYSTEMS

18.1 GENERAL

18.1.1 BOARD STORAGE

Boards should be stacked on a level surface in a dry place, preferably inside a building, and properly protected from damp and inclement weather. If boards are to be stacked on a concrete floor inside a building, a damp-proof membrane should first be laid down, or a timber platform should be provided. A suitable platform for all boards can be constructed from timber bearers 75 x 75mm spaced at 400mm centres. The ends and edges of the boards should be neatly aligned.

Boards stored outside should be stacked on a level platform of timber bearers as described above, off the ground. The stack should then be completely covered with a securely anchored polythene sheet or tarpaulin.

18.1.2 BOARD HANDLING

When board is manually off-loaded or stacked it should be carried on edge, two men to a pair of boards. Boards should not be carried with the surfaces horizontal, since this imposes an undesirable strain on the core. When a board is stacked or removed from a stack, the long edge should be placed down before it is turned horizontally.

Boards should not be slid over each other as this can scuff the surface. Board is particularly suited to mechanical handling, but this should be done with care. Forklifts should be equipped with multi-pronged forks to handle boards exceeding 3000mm in length.

18.1.3 BOARD CUTTING

Place the board flat on a level surface with the face upwards. Demarcate the cut. Place a straightedge next to the mark and with a sharp utility knife cut through the face layer of paper. Slide the board over the edge of the level surface or stand it on edge. Snap the core of the board and non-plasterboard cut through the back layer of paper.

When required to cut an L shape out of a board, one limb must be cut with a fine-toothed saw and the other limb with a utility knife, as described above.

18.2 PLASTERBOARD AND FIBRE CEMENT BRANDERED CEILINGS

18.2.1 SPECIFICATION

18.2.1.1 BRANDERING

Truss (Tie Beam) spacings will determine the size of brandering to be used.

Truss spacing	Brander size
Up to 1 000 mm	38 mm x 38 mm
1 001 mm - 1 200 mm	38 mm x 50 mm (with 50 mm dimension vertical)
1 201 mm - 1 400	50 mm x 50 mm

Note: All sizes refer to SABS approved V5 SA pine, steel brandering or “black cross”.

18.2.1.2 BRANDER CENTRES

Type of ceiling	Brander Centres	Board fixings
6.4mm Plasterboard M-Strip	400mm centres in one direction only.	32mm Grabber screws spaced at 150mm centres.
6.4mm Plasterboard plastered ceilings	300mm centres in one direction only.	32mm Grabber screws spaced at 150mm centres.
9-9.5mm Plasterboard flush jointed ceiling	500mm centres in one direction only.	32mm Grabber screws spaced at 150mm centres.
9-9.5mm Plasterboard flush plastered ceilings	400mm centres in one direction only.	32mm Grabber screws spaced at 150mm centres.
12-12.5mm Plasterboard flush jointed ceiling and plastered	600mm centres in one direction only.	32mm Grabber screws spaced at 150mm centres.

Note: Semi-clout nails should not be used under any circumstances. Use of Grabber screws is preferred.

18.3. FIXING OF BRANDERING

Branding is nailed to the tie beams at centres indicated on the table above (18.2.1.2) using a 75mm or 100mm nail. In all cases a brander should be provided at 38mm away from the wall line, for fixing 75mm cove.

Level the branding, starting from the lowest point. Insert a wedge in the gap between the brander and the tie beam if required and secure the brander with a skew nail. In cases where the gap exceeds 13mm, the use of a cleat is recommended. (See Fig. 1 & 2.)

Note: Light fittings must be fixed to the branding or conduit, not to the board.

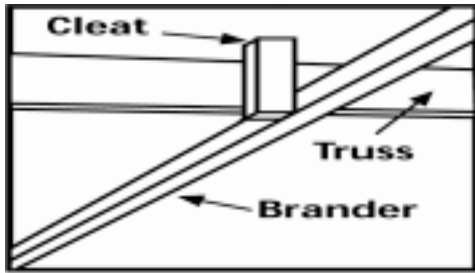

FIG. 1

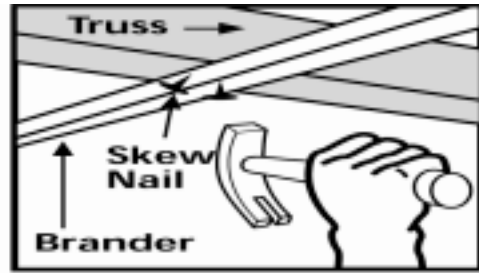

FIG. 2

18.4 PLASTERBOARD ON TIMBER BRANDERING

Plasterboard must **ALWAYS** be fixed with the length of the board at **RIGHT ANGLES** to the branding. Plasterboard is fixed with the printed side up (face side down) for direct decoration or for plastering. Always nail or screw from the centre of the board outwards. The gap between boards should not exceed 2mm.

18.4.1 GYPSUM M-STRIP/H-SECTION, 6.4 mm PLASTERBOARD

Fix the first plasterboard up to 150mm from long edge. Slip M-strip over the edge of the board with the narrow flange facing down. Slip second board into M-strip and fix both boards to within 25mm from M-strip. (M-strip is not fixed at all.) In the case of end joints, fix two parallel branders at 100mm centres with the ends of both boards overlapping the respective branders by +30mm. (See Fig. 3 & 4.)

Long Joint 6.4mm board

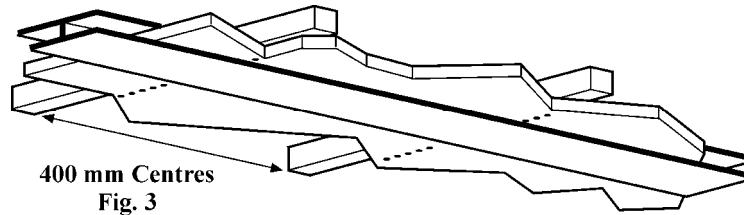

Fig. 3

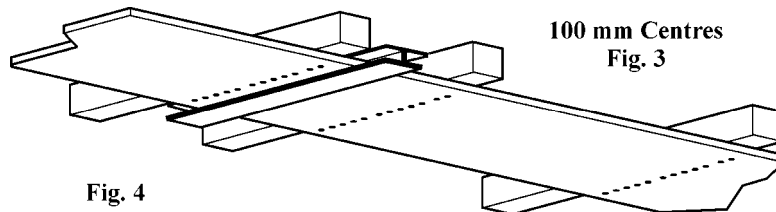

Fig. 4

18.4.2 PLASTERBOARD GYPSUM PLASTERED CEILINGS

Fix BOARD at right angles to branders so that the end joints fall on a 50mm brander. No brandering is required behind long edge joints. Nail at 150mm centres. Apply fibre tape over all joints, double over butt joints. If wire scrim is used, fix with staples or nails. (See Fig. 5). Apply not less than 3mm of gypsum finishing board or Crete stone as per data sheet for gypsum finishing board and gypsum finishing plaster.

Note: It is recommended that the ceiling be plastered the same day that the plasterboard has been erected. On large areas, check with Engineer to determine if expansion joints are required.

18.4.3 PLASTERBOARD FLUSH JOINTED CEILINGS 9/9.5mm and 12/12.5mm BOARD

Fix Taper-edge plasterboard at right angles to brandering so that the butt joints fall on a 50mm brander. Screw at 150mm centres. All joints should be jointed as per data sheet for drywall hand jointing application.

Note: The use of nails is not recommended for fixing plasterboard of these thicknesses.

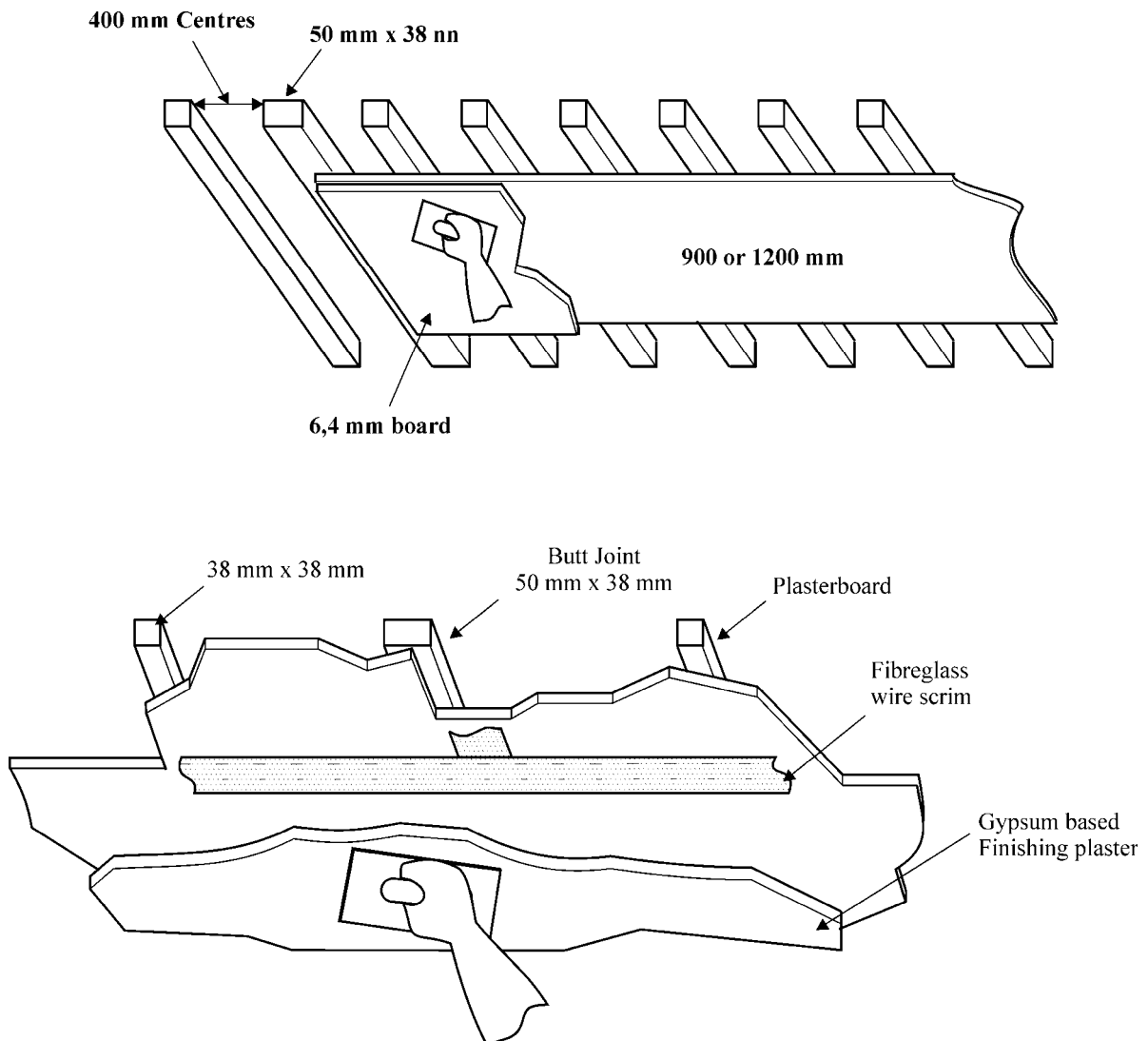

18.5 FIBRE CEMENT BRANDERED CEILINGS

18.5.1 INSTALLATION PROCEDURES

Table 1: Standard Brander/Truss spacing	
Truss or rafter spacing (mm)	Brander size required (mm)
1 050 (maximum)	38 x 38
1 500 (maximum)	38 x 50 on edge

NB: Specially designed brander is required for truss or rafter spacings in excess of those shown in this table. Please note that steel brander can be used as an alternative to timber brander.

18.5.2 BRANDERING REQUIREMENTS

The spacing of brander shown in Table 2 is based on practical tests carried out for the various thicknesses of ceiling boards. Cross brander is necessary at the joints and when cornices are to be fixed at right angles to the brander.

Table 2: Spacing of brander for standard boards (Step 1)	
Board thickness (mm)	Maximum brander centres (mm)
4	450
6	600

NB: With plastered ceilings, it is recommended that 6mm thick ceiling boards be used.

USING H-PROFILE JOINTING STRIPS

STEP 1 – Using H-Profile Jointing Strips

- Starting at one end of the room and at right angles to the trusses, nail a length of brander to the tie beams of the rafters 25mm away from the wall. Nail another length of brander to the tie beams on the opposite end of the room, 25mm away from the wall.
- Bearing in mind the maximum spacing required, refer Table 2 above, commence at the first piece of brander erected and mark the spacings for the brander on the tie beam next to one wall. Repeat this on the tie beam at the opposite side of the room. With the aid of a chalk line, mark the remaining tie beams accordingly. Skew nail brander to the tie beams on the lines marked.
- To provide for fixing the cornice, fix short pieces of brander 25mm away from the walls at right angles to and between the brander already installed.
- Install supporting timber where light fittings are to be suspended from the ceiling.

Figure 7: Installation of supporting brandering

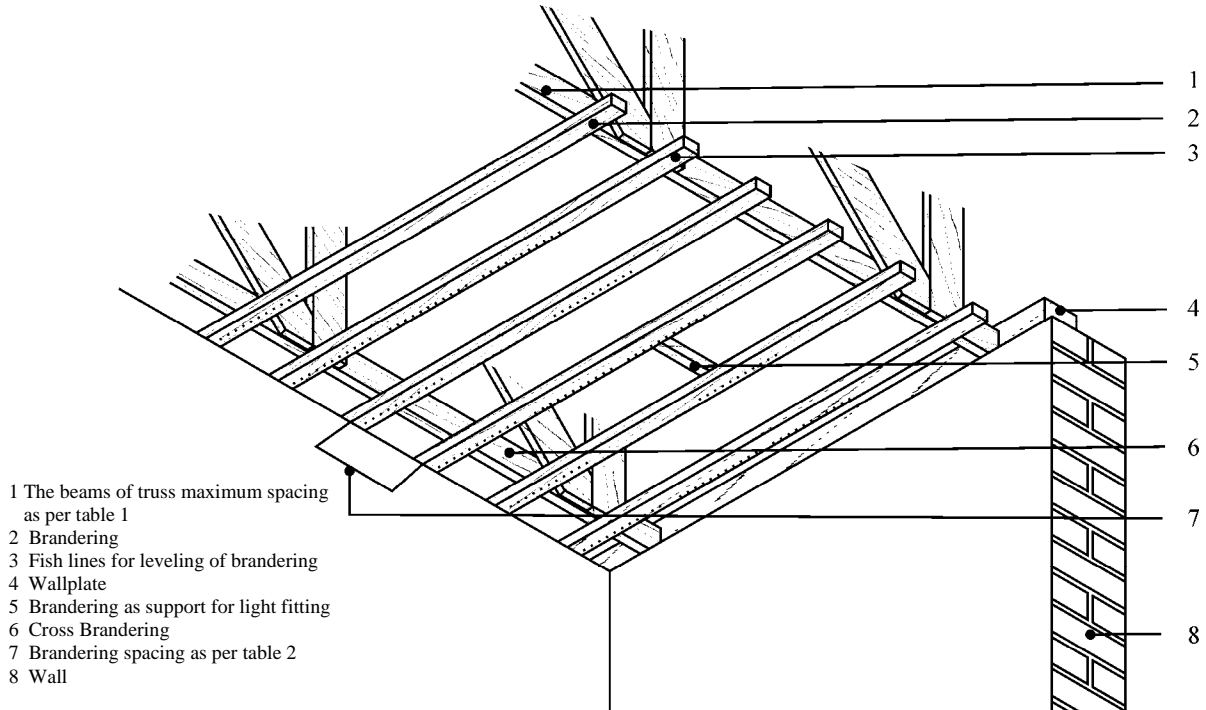

STEP 2 - Levelling the brandering (See Fig. 7 & Fig. 8)

- To check the level of the brandering, span a fish line across the room in various positions.
- Use wooden wedges to level where necessary.

Figure 8: Levelling the brandering by wedging

- 1 Tie beam of truss
- 2 Timber wedge
- 3 Brandering

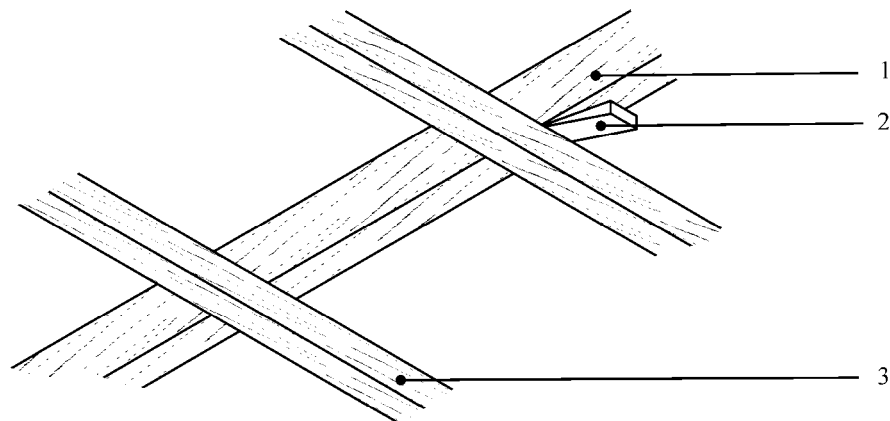

STEP 3 - Installing the ceiling boards (See Fig. 9)

- Measure the length and width of the room to establish the number of full boards required.

Space the boards so that the standard width boards are fixed from the centre, finishing off with equal cut boards at each side of the room.

- Starting from the middle, place the ceiling boards at right angles across the brandering on the positions previously established and nail in place with 32 x 2.5mm full cloud ceiling nails, 25 x 2.5mm chipboard screws or 32mm grabber screws. Use dry wall or 25 x 3.5mm chipboard screws with steel brandering. The nails should be placed at 150mm centres and not closer than 12mm to any edge of the board.

- Push an H-profile jointing strip onto the long edge of the board. Fit the next board into the H-profile strip and fix that board.
- Fit H-profile cross-sections, cut to size, onto the short edges of the board.
- Repeat this procedure until the ceiling is complete.

Note: If more than one board is required for the length of the room, the best effect is achieved with staggered joints.

Figure 9: Installing the ceiling boards

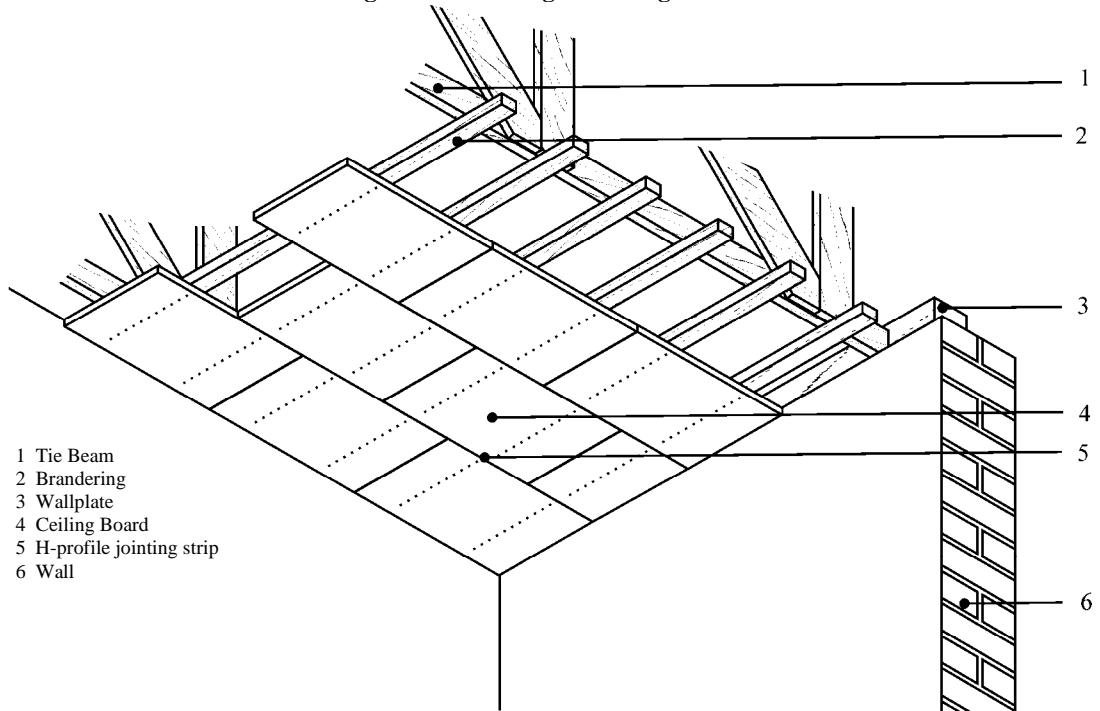

18.6 STEEL BRANDERING

Steel brandering is the preferred method used by SABISA members. Steel brandering is designed as an alternative to conventional timber brandering and offers the following advantages.

- Reduced weight for transportation and easier handling.
- Guaranteed straightness of long sections.
- Quick and easy levelling by means of the suspension bracket/levelling clip.
- Reduced waste due to availability of different lengths.
- Improved accuracy.
- Easier cutting on site.

18.6.1 INSTALLATION DETAIL

Steel branderling should be installed as follows.

Type of ceiling	Brander Centres	Board Fixing
4mm Fibre-cement	450mm centres in one direction only	25 x 3.5mm chipboard screws
6mm Fibre-cement	600mm centres in one direction only	25 x 3.5mm chipboards screws at 150mm centre
6mm and 6.4mm board M-strip	400mm centres in one direction only.	25mm drywall screws spaced at 150 mm centres.
6mm and 6.4mm board plastered ceilings	300mm centres in one direction only.	25mm drywall screws spaced at 150 mm centres.
9-9.5 mm board flush jointed ceiling	500mm centres in one direction only.	25mm drywall screws spaced at 150 mm centres.
9-9.5mm board flush plastered ceilings	400mm centres in one direction only.	25mm drywall screws spaced at 150 mm centres.
12-125mm board flush jointed ceiling and plastered	600mm centres in one direction only.	25mm drywall screws spaced at 150 mm centres.

The branderling sections should be fixed at 90 degrees (right angles) to the roof trusses with wood screws or nails of suitable length. Branderling should not exceed the 1 200mm truss spacing. For applications over 4200mm, a joiner section should be used to join two pieces of branderling. Branderling may be fixed directly to the bottom of the trusses or suspension brackets may be used where necessary. Where suspension brackets are used, consult the truss designers.

Note: The board must be fixed at 90 degrees to the steel branderling: i.e. parallel to the roof trusses, using drywall screws at 150mm centres.

The steel branderling system can be used with either the M-strip detail or for a flush plastered or jointed ceiling, as per standard timber branderling.

18.7 FLUSH PLASTERED CEILINGS

18.7.1 SPECIFICATION

Install grid with main tees (3 600mm lengths) at 1 200mm centres and the cross tees (1200mm lengths) at 600, 500 or 400mm centres, with capping of galvanized steel. Taper-edge (12-12.5mm or 9-9.5mm) board should be screwed to the underside of the ceiling grid with drywall screws spaced at 150mm centres. The grid is knurled to help locate the screws easily. Fix Taper-edge plasterboard at right angles to the cross tees.

Make sure an additional cross tee is added on a butt joint if the butt joint doesn't fall on one. Screw the board to the grid at 150mm centres. All joints should be jointed as per data sheet for drywall hand-jointing application.

Note: Where 12-12.5mm plasterboard is used, cross tees can be at 600mm centres; where 9-9.5mm plasterboard is used, cross tees shall be at 400mm and skim plastered. Refer to gypsum finishing plaster data sheet for plastering specifications.

18.7.2 PLASTERED FIBRE-CEMENT CEILINGS

Ceilings need to be 6mm thick and laid longitudinally with the branderling. Wood or Top Hat steel or aluminium branderling is recommended. When c-sections are used, double sections are required where boards join. See the drawing below.

NB: Ceiling substructure needs to be rigid to prevent movement.

- Measure the length and width of the room to establish the number of full boards required.
- Edges of boards where they join to be chamfered.
- Space the board so that the standard width boards are fixed from the centre, finishing off with equal cut boards on each side of the room.

- Ensure that the boards join in the centre of the brandering. Use chipboard or drywall screws to secure the boards to the brandering.
- Do not use nails. Screws should be spaced 150mm apart along the edges and on the interim brandering.
- Tape the chamfered joint with fibre-tape.
- Apply a polymer cement-based plaster to cover the joint. Sand lightly when dry.
- Apply a calcium carbonate polymer-based finishing plaster to cover the joint and the immediate surrounding surface area of the board. When dry, sand till smooth.

Or

Skim the complete surface with a high polymer-based skimming cement-based skimming plaster. Contact the manufacturers for recommendations on suitable plasters.

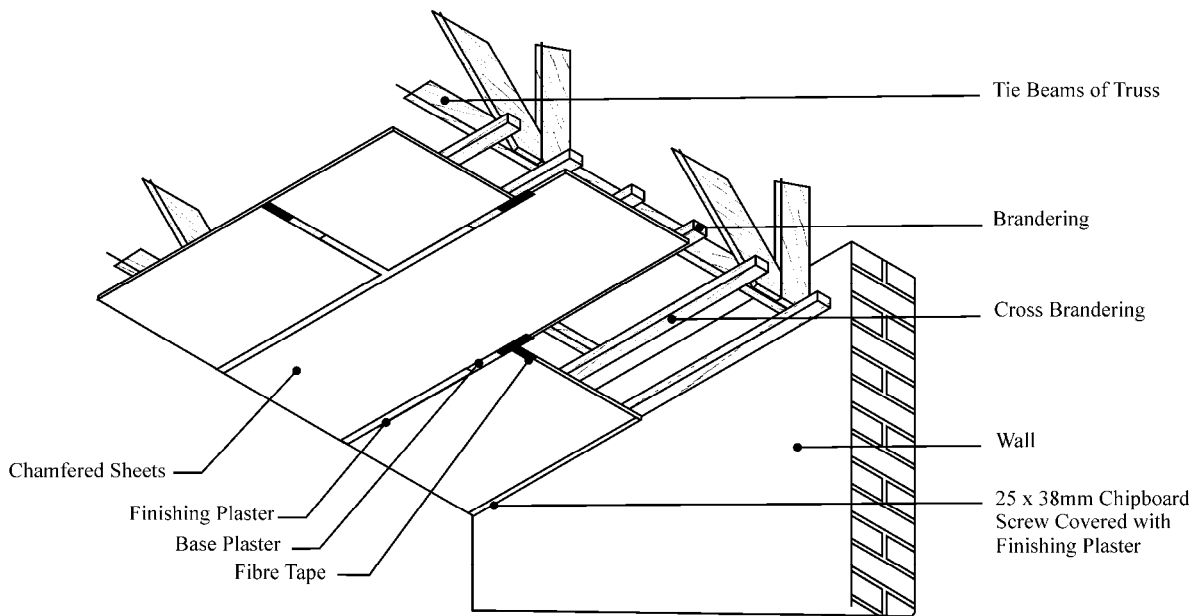

18.7.3 CEILINGS: INSTALLATION DETAIL

Recommendations for suspending of grid

Subject to loading detail, suspension should not normally exceed 1 200mm centres. The suspension must not be out of plumb by more than 25mm for each 150mm of plenum depth and in no case should it exceed 500mm over a depth of 3 000mm.

Whenever the above is exceeded and/or when the suspension angle is more than 2 000mm long, a sub-grid is recommended.

Sub-grid, when used, should be formed using burgess channel. In no case should the suspension be from other services in the ceiling void. An angle suspension point must be installed on the main tees within 400mm from the wall angle. Where cross tees exceed 600mm and rest on the wall angle, these should have additional suspension.

All flush plastered ceiling must be constructed or suspended using 25 x 25mm or 20 x 20mm angle. No fewer than two steel pop rivets or wafer head tek screws should be used, with a shear strength three times that of the maximum allowed ceiling load. The angle can be fixed in a number of different ways, depending on the structure to which it is being fixed.

18.7.4 FIXED CEILINGS

(a) Fixed Ceilings

The boards are fixed to the grid with drywall screws at 150mm centres. The Plaster grid is knurled to help locate the screws easily into the grid and reduce slipping of screws.

(b) Ceiling Joints

Fibreglass/wire scrim is placed over the joints to assist with the bonding of the jointing materials as well as to strengthen the joints. The joints are then covered with a jointing plaster.

(c) Flush Plastered / Skimmed Ceilings

Fibre glass/wire scrim is placed over the joints to assist with the bonding of the plaster and the entire surface then covered with a formulated gypsum board finishing plaster or a one-coat plaster. The joints are finished as per flush plaster ceilings, using a formulated gypsum board finishing plaster. The coat of skimming plaster is applied over the entire surface area.

Note: Boards are fixed at right angles to the cross tees, with printed side facing up.

18.7.5 DECORATION

18.7.5.1 BOARD DECORATION

Before decorating check the entire surface to see that nail holes, taped joints, etc. have been filled and sanded satisfactorily. Ensure that the boards are free from powder and dust. For improved paint finishes, it is suggested that a good quality oil based plaster primer be applied to the entire surface.

(a) M-Strip Ceilings

Stop all nails and screw heads with a gypsum filler and sand down when dry.

(i) Galvanised and Aluzinc M-Strip

- Lightly sand to create a key.
- Apply one coat etch primer.
- Apply two coats of PVA.

(ii) Chromaprep M-Strip

- Be careful not to remove the chromaprep layer.
- Apply two coats of super acrylic PVA directly to surface.

(iii) Plastic H-Strip

- No primer necessary.
- Apply two coats of super acrylic PVA.

(b) Plaster Ceilings

Before decorating check the entire surface carefully to see that the plaster has set hard, that it is dry and free from powder and dust. It is recommended that all gypsum plaster surfaces be sealed with oil or solvent based sealer such as paint bonding liquid, or a pigmented plaster primer suitably thinned down with mineral turpentine. Allow to dry for 24 hours before applying two coats of paint, as required.

19. GRID CONFIGURATIONS

See Annex 1

20. FIXED PLASTERBOARD SYSTEMS

Alternative Fixed systems may be available; however, board fixing remains the same. Fixing instructions must be provided by the supplier. Plasterboard fixings must comply with South African Standards.

ANNEX 1

**GRID CONFIGURATIONS
&
SETTING-OUT GUIDELINES**

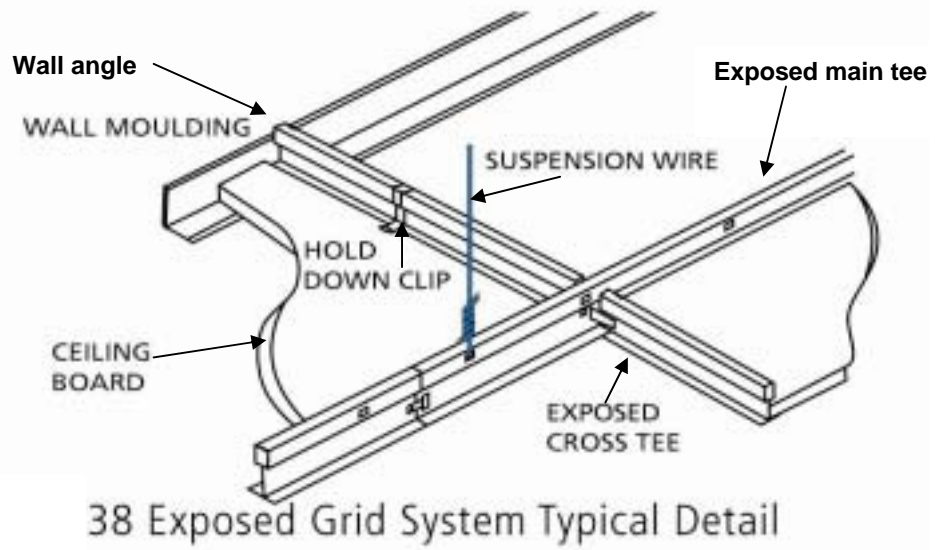

SETTING OUT GUIDELINES

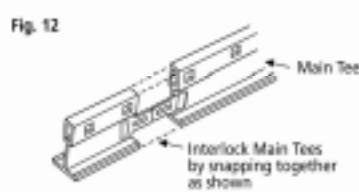
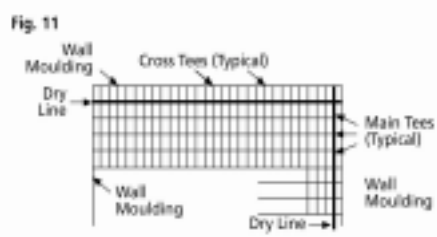
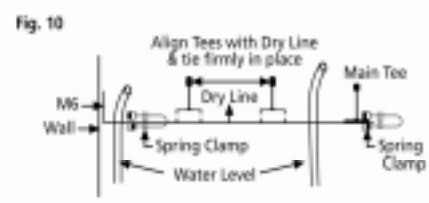
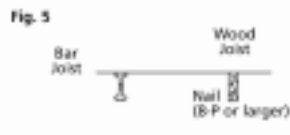
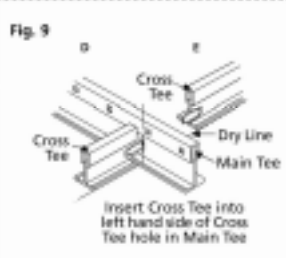
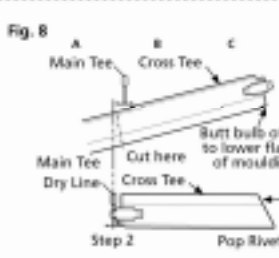
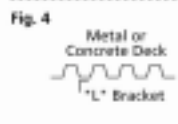
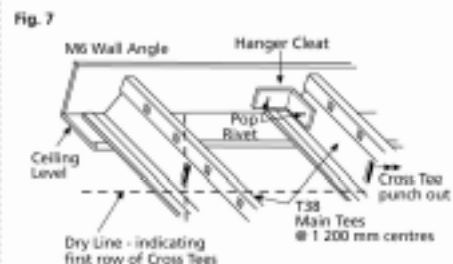
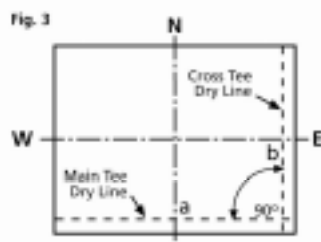



COMMON FLUSH PLASTER GRID LAYOUT

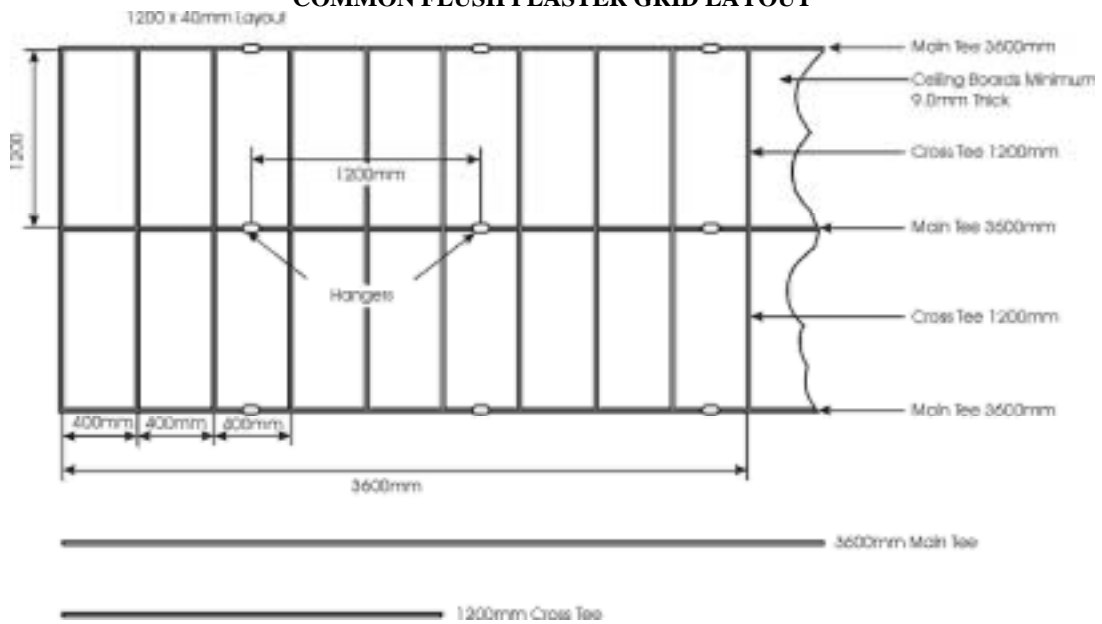

COMMON GRID LAYOUT

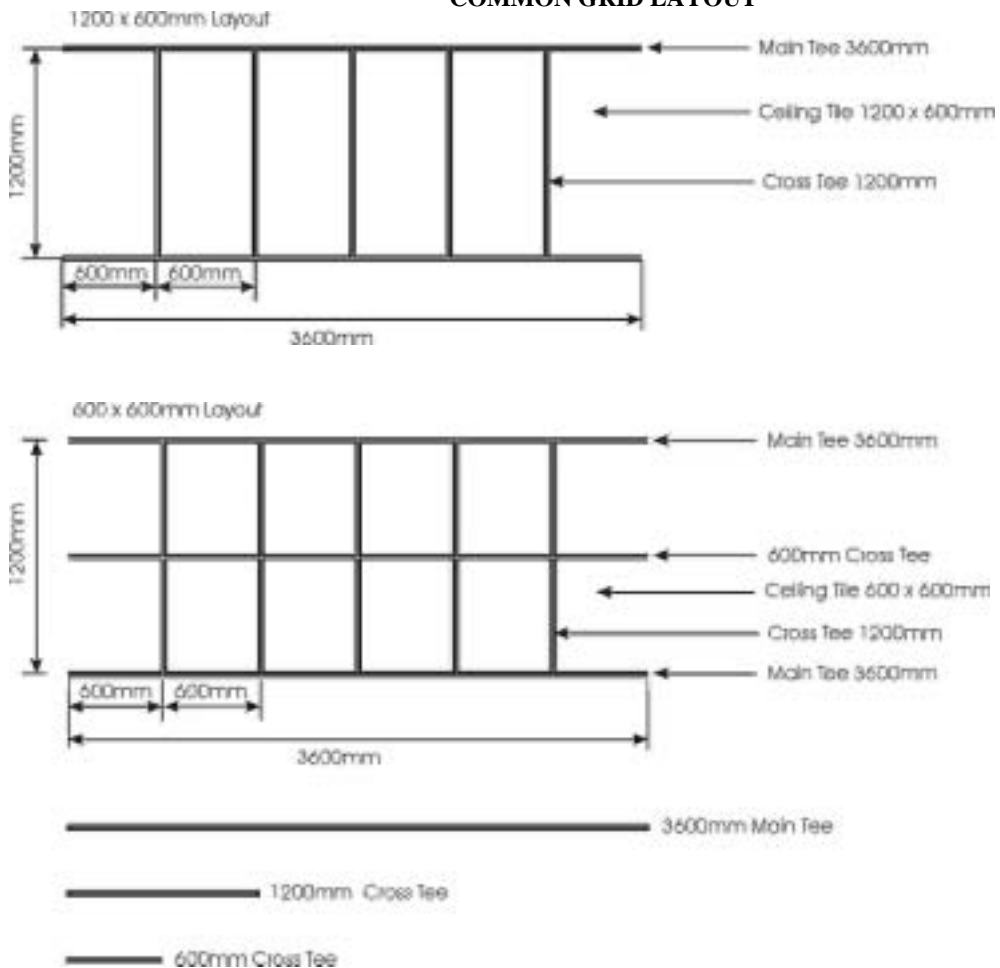



South African Building
Interior Systems Association

COMMON GRID LAYOUT

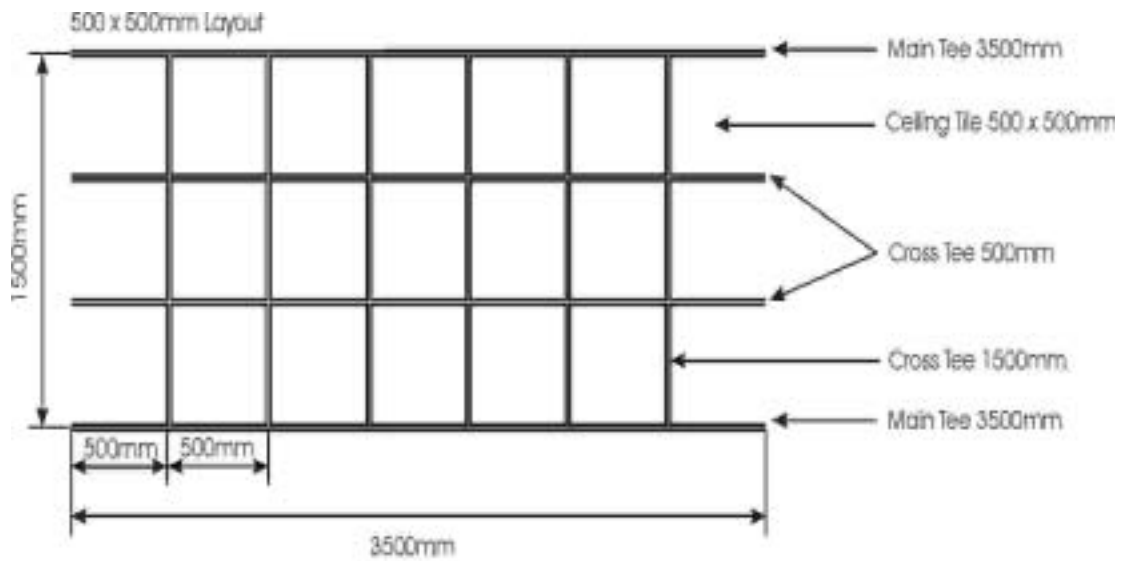
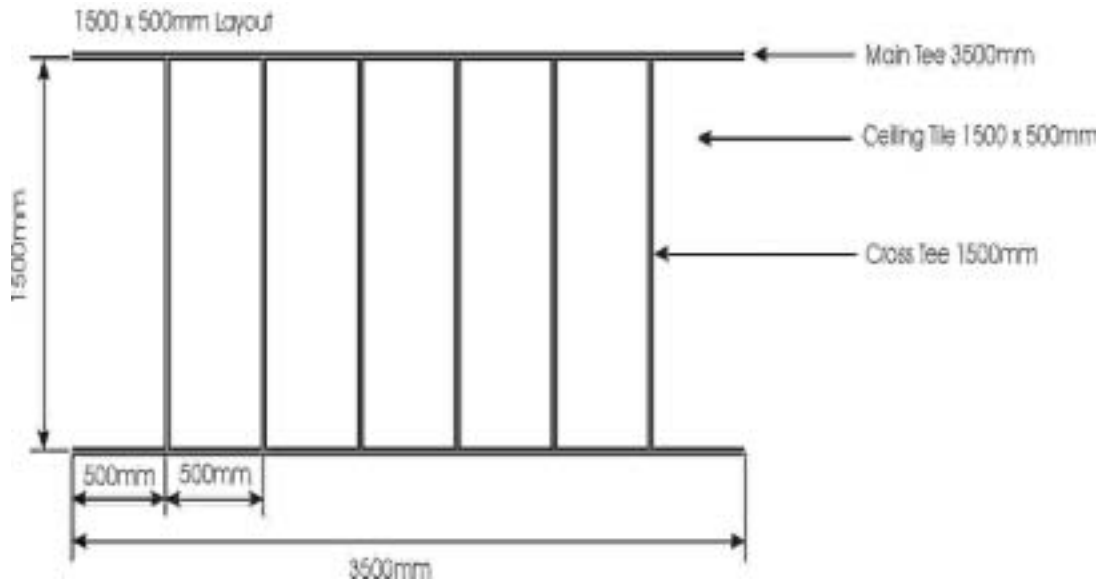

 3500mm Main Tee

 1500mm Cross Tee

 500mm Cross Tee

ALTERNATIVE GRID LAYOUT

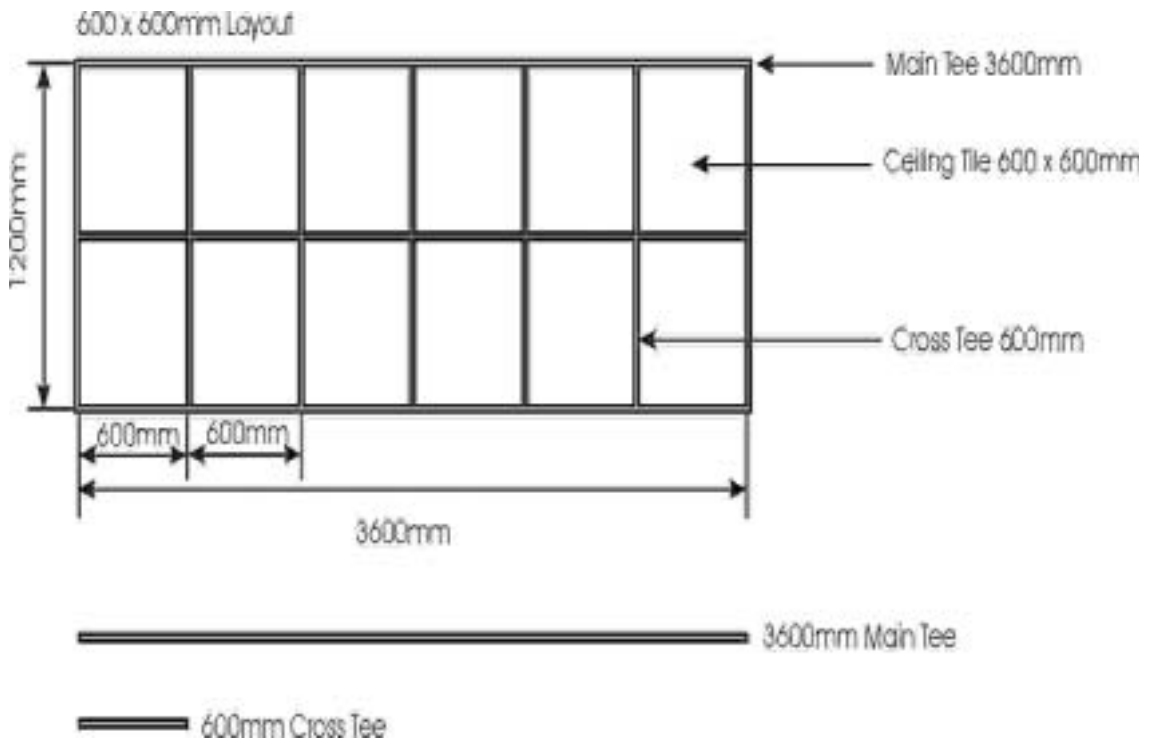
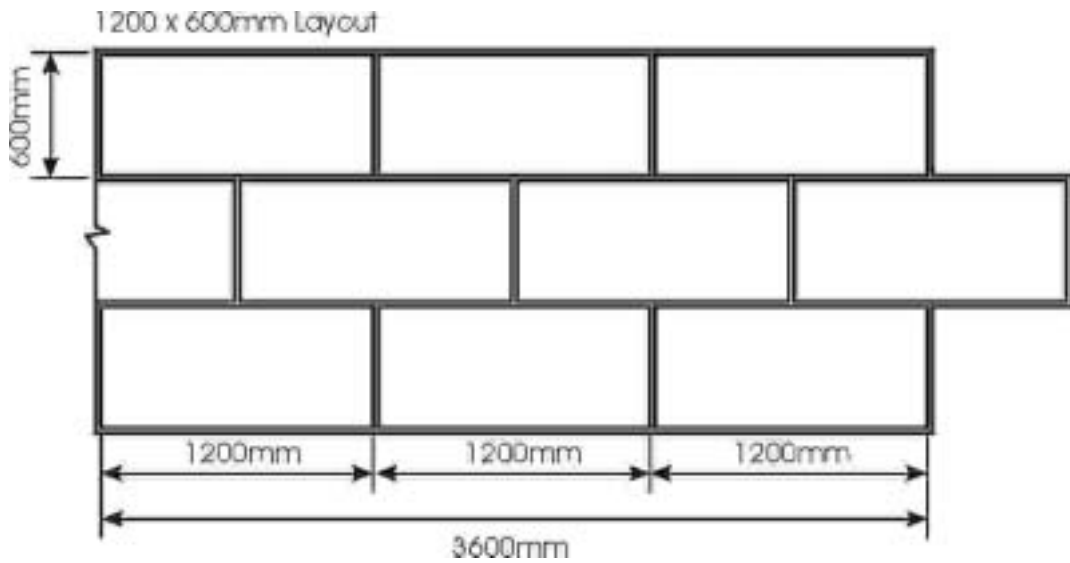

● **Note:** The difference between this and the common method is the spacing of the main tees. This is a more labour intensive method of installing a ceiling. No difference in aesthetics.

ALTERNATIVE GRID LAYOUT

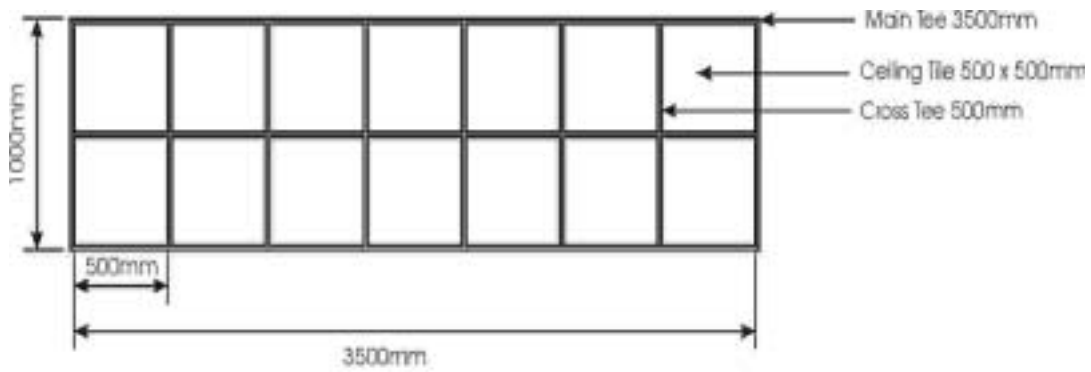
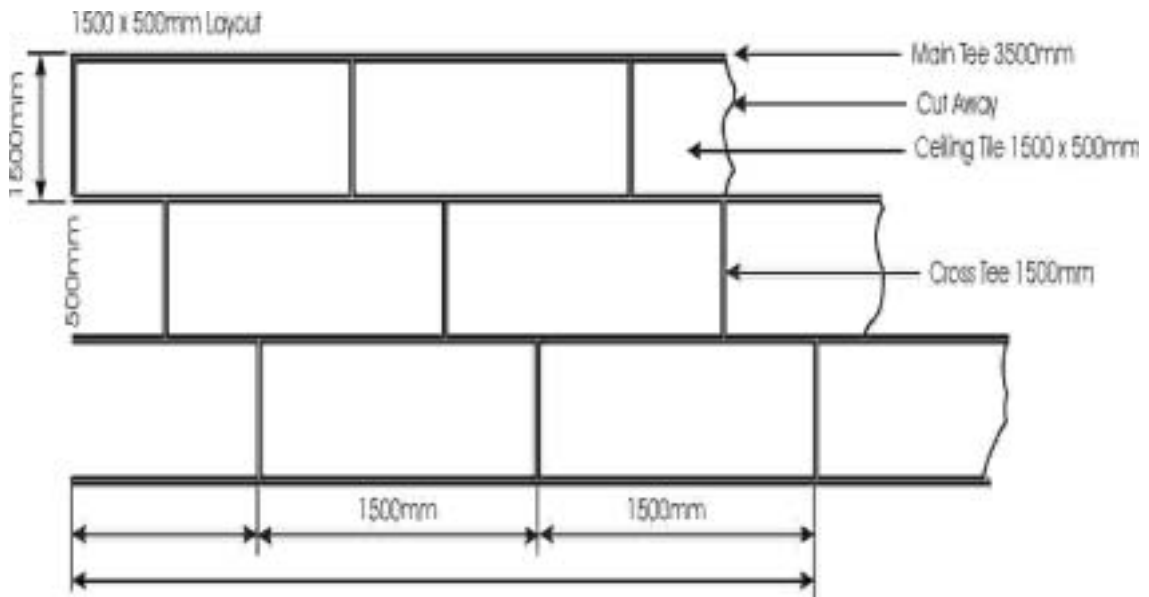

————— 3500mm Main Tee

————— 500mm Cross Tee

● **Note:** The difference between this and the common method is the spacing of the main tees. This is a more labour intensive method of installing a ceiling. No difference in aesthetics.



South African Building
Interior Systems Association

ANNEX 2

FIXING MATERIALS

Drywall Self Tapping

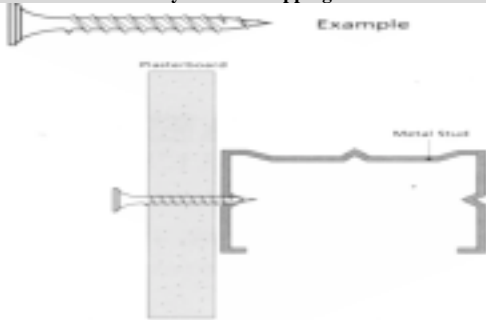

For attaching plasterboard to light gauge metal stud partitioning and ceiling system

Length mm	Gauge
22	6
25	6
32	6
38	6
41	6
44	6
51	7
57	7
63	8
73	8

Pan Head Self Tapping

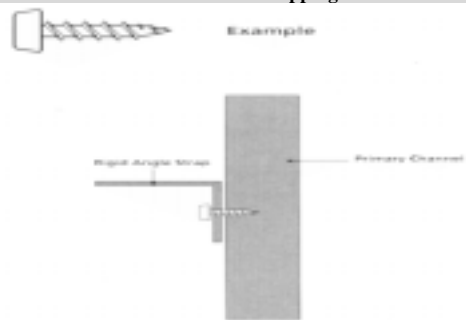

For connecting light gauge metal components

Length mm	Gauge
11	7

Trim Head Self Tapping

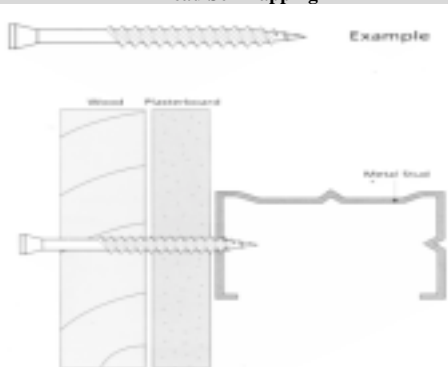

Self embedding screw for attaching wood trims to metal

Length mm	Gauge
41	7
57	7

Wafer Head Self Tapping

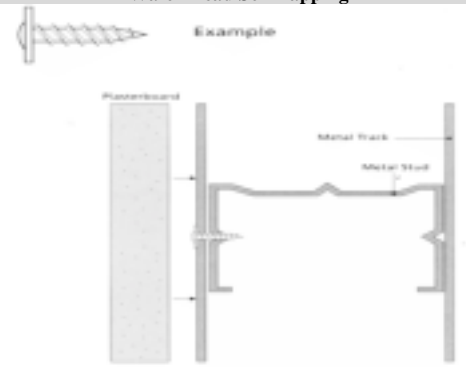

Low profile head for connecting light gauge metal components beneath plasterboard

Length mm	Gauge
14	8

Toughcheck Self Tapping

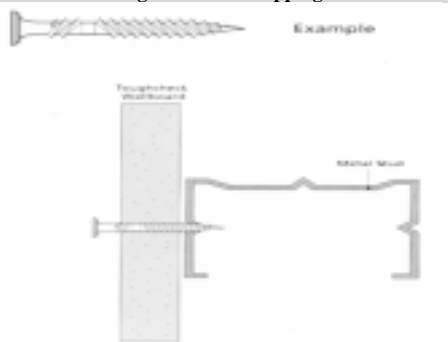

For attaching Toughcheck Wallboard to light gauge metal and ceiling systems. (previously known as Robust Self Tapping)

Length mm	Gauge
25	7
41	7

Checkpoint Self Tapping

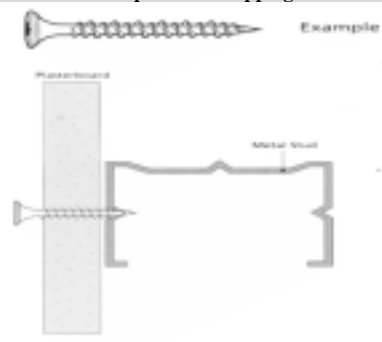

A Drywall screw specifically designed for fixing high performance boards

Length mm	Gauge
25	6
41	6

All drawings not to scale

Laminating High Thread

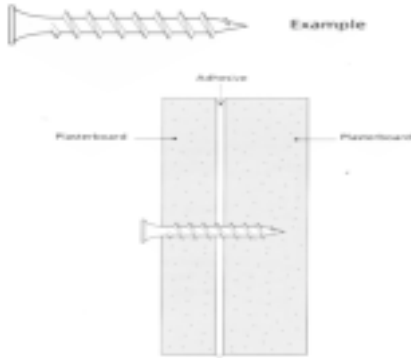

High grip screws for retaining plasterboards in laminating partitions

Length mm	Gauge
32	10
38	10
44	10

Drywall High Thread

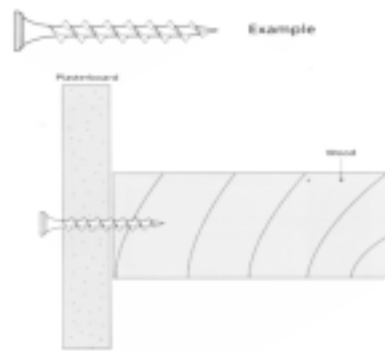

For attaching plasterboard to timber stud partitioning and ceiling joints

Length mm	Gauge
32	6
38	6
41	6
51	7
63	8
76	8

Pan Head Self Drilling

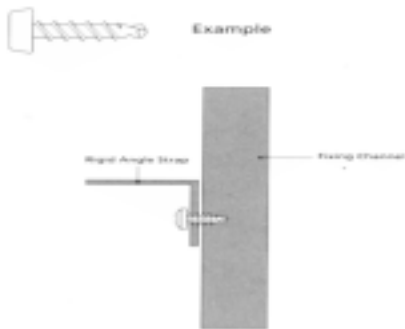

For connecting heavy gauge metal components

Length mm	Gauge
11	6

Wafer Head Self Drilling

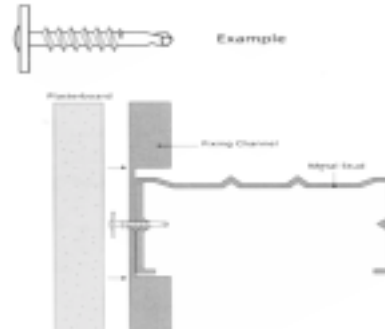

Low profile head for connecting heavy gauge metal components beneath plasterboard

Length mm	Gauge
14	8

Toughcheck Drywall Self Drilling

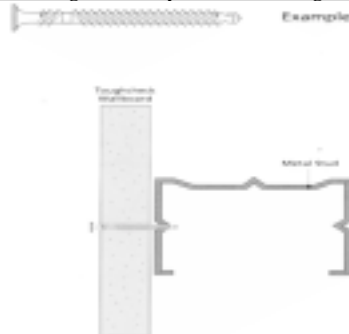

For use with Toughcheck Wallboard in multi-layer applications and for attaching plasterboard to heavy gauge metal wall system. Previously known as Robust Drywall Self Drilling

Length mm	Gauge
38	7

Drywall Self Drilling

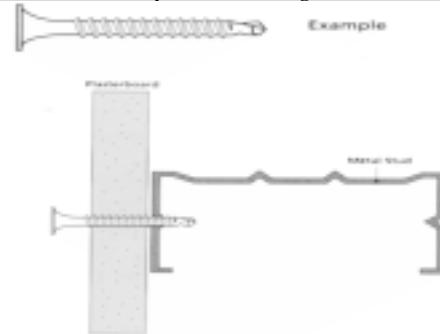

For attaching plasterboard to heavy gauge metal stud partitioning and ceiling system

Length mm	Gauge
25	6
32	6
38	6
41	6
44	6

All drawings not to scale

ANNEX 3

TYPICAL POLYSTYRENE CORNICE TRIMS



South African Building
Interior Systems Association

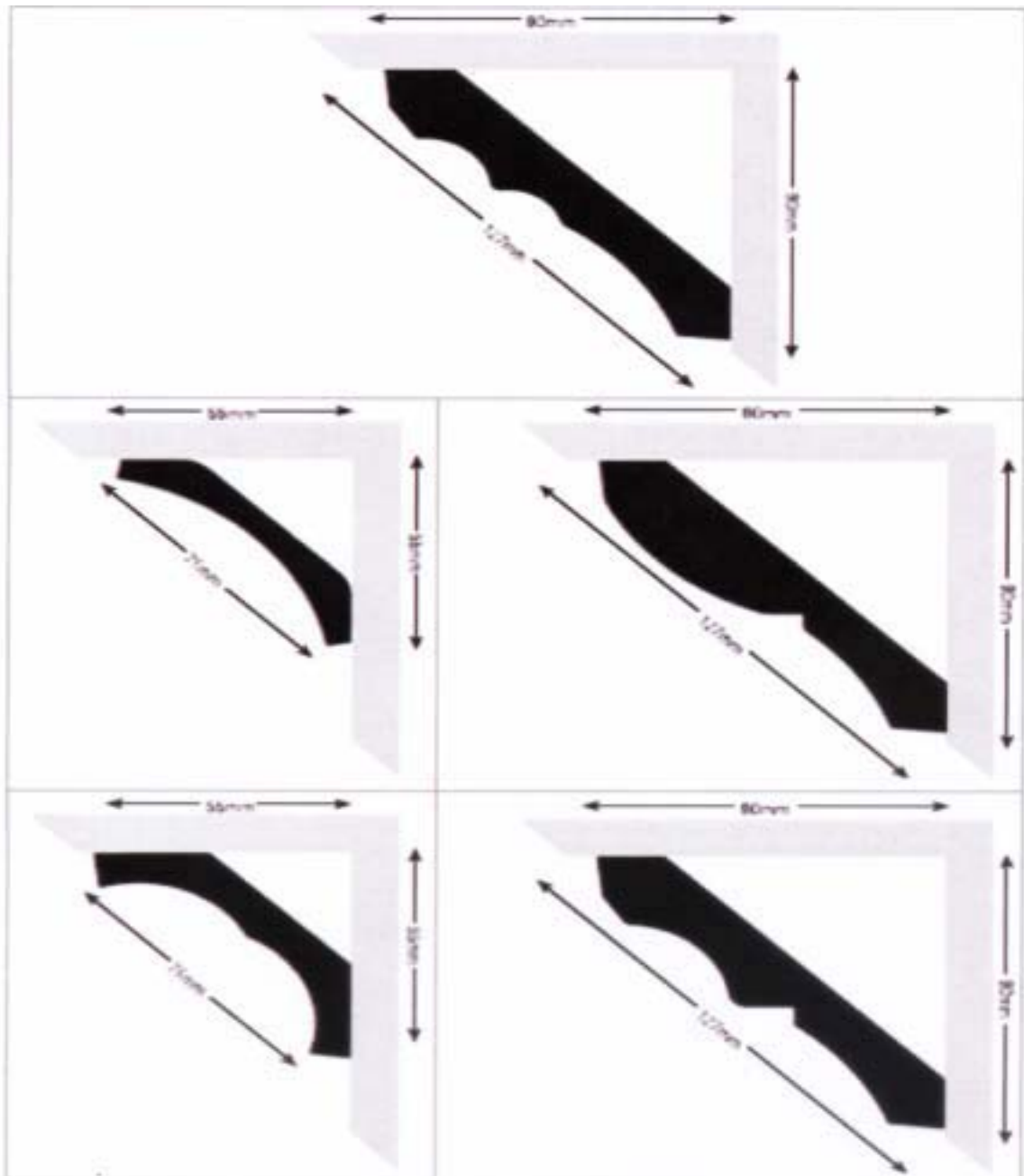

ANNEX 4

ACOUSTIC INSULATION

Facings General

Some insulation products require a membrane or porous facing for protection and/or appearance. The facing chosen must allow the sound waves to pass easily through the product and enter the acoustic insulation, as an example pine perforated facings. This normally requires discussion between the professional team to arrive at a suitable facing which is acceptable to all. (Performance, appearance, safety, durability and costs.)

Open plan offices

The use of acoustical screens or dividers can be effective in reducing noise distractions which often occur in multiple occupancy offices such as call centres for example. Installation of these screens possibly in conjunction with wall and ceiling acoustical treatment can improve speech privacy. Alternatively sound masking (a term to describe electronically generated broadband sound which masks the unwanted speech intelligibility between work stations or zones) can be considered.

Sound Isolation

It is the design and treatment to walls, floors, doors, roofs, ceilings, windows and openings, etc. to reduce the amount of sound transmitted through these items to a level which is desirable for the room's intended use.

Note:

Whilst this is often achievable certain practical and feasible aspects require to be taken into account with regard to material selection, laminations, protective facing and coverings as well as resistance to weather conditions, if applicable.

Floors

A floating floor is a construction which independently isolates the upper surface (floor slab or laminate) from the lower structure surface using specific isolators. These isolators vary in type and application and are chosen to suite the particular application.

They would include the following:

- Anti-vibration mounts
- Flexible pads
- Acoustical mineral fibre products
- Acoustical polyester products
- Closed cell elastomeric foam
- Cork particle board
- Polystyrene
- Polyurethane/Polyisocyanurate

Note:

Choice of products would also be subject to fire safety compliance.

Floating floors are normally a mandatory requirement in the case of recording studio's, music practice rooms, drum recording booths, broadcasting studios and audiometry rooms but can be extended to plant rooms, conference halls and even hotel rooms and certain apartment buildings if the problem is serious enough.

Floating floors contribute to a large extent in reducing structural borne noise.

Note:

Carpeting with heavy underfelt can give a reasonable effect on impact noise reduction.

CEILINGS

It is only required if the type of roof and roof system do not already provide adequate sound isolation. Mass is normally a requirement here and a concrete slab is generally very effective. (Subject to structure borne noise having been addressed).

Alternatively, a multi-laminate ceiling requires to be installed which will normally include heavy density, uniformly flat, products together with acoustical absorbing boards or blankets "sandwiched" in between.

Subject to the function of the room it is often advisable to also install a full, or semi, acoustical facing or a ceiling using acoustical ceiling tiles or materials which have sound absorbing qualities.

The acoustical design will vary dependent on the type of venue.

WALLS

Partition walls or Drywall construction is becoming more and more popular due to its inherent advantages of speed and lightweight.

Drywalls consisting of a light steel frame clad on both sides with plasterboard or other approved sheeting material require more attention to acoustics than do masonry structures but can achieve similar results.

Acoustic insulation of Drywall is achieved by either multiple layers of cladding material or by filling the cavity between the studs with bulk fibrous insulation materials of a thickness similar to or slightly thicker than the width of the stud.

It is also important to ensure that all abutments to other walls, ceiling and floor is sealed with a sealing rubber or a flexible silicone sealer. Any air leakage path is a source of noise transmission. For special applications where acoustic insulation is specified it is good practice to take the drywall right up to beneath the soffit or roof to provide a proper seal."

WINDOWS

Double glazing is often used to improve sound isolation for windows. Acoustical consultants will advise on the choice of the types of glass, preferably of different thicknesses and also the recommended gap between the panes which is very important.

All joints must be completely airtight. Window frames should be designed so as to minimise the possibility of structure borne sound.

DOORS

The minimum requirement for doors is perimeter sealing.

Often doors have one or more of the following problems:

- No seals around the perimeter and also at the base of the door and threshold.
- Seals wrongly installed
- Incorrect choice of seals.
- Seals which do not make adequate contact between door and door frame.

Mass, thickness and type of door are equally important factors to be considered. Lightweight doors should be avoided. The practice of having two sets of doors with a connecting acoustically lined corridor is a very effective feature assuming, the room, or entrance, can accommodate this.

VENTILATION DUCTS

A considerable amount of noise can be transmitted via A.C. and ventilation ducting. Often the noise from in-line fans exacerbates this problem. Fans should be installed on flexible mountings. The fan casing may also require to be insulated.

Internal and external lining of the ducting and/or the addition of noise attenuators may be required to reduce noise levels.

Sound leaks – General

These are identifiable sound leak patch such as openings, gaps and cracks as well as conduit, cable. Ventilation and piping runs which allow airborne sound to be transmitted.

Apart from badly sealed doors, windows and openings between walls and floors or ceilings other items of concern include:

- Recessed lighting installed in suspended ceiling which share a common plenum with adjacent rooms.
- Keyholes of doors.
- Louvers in doors.
- Air vents in walls.
- Suspended ceiling which pass over a dividing wall or partition.



South African Building
Interior Systems Association

MATRIX



South African Building
Interior Systems Association

MATRIX